

# 贝加莱柔性制造

PERFECTION IN AUTOMATION  
A MEMBER OF THE ABB GROUP

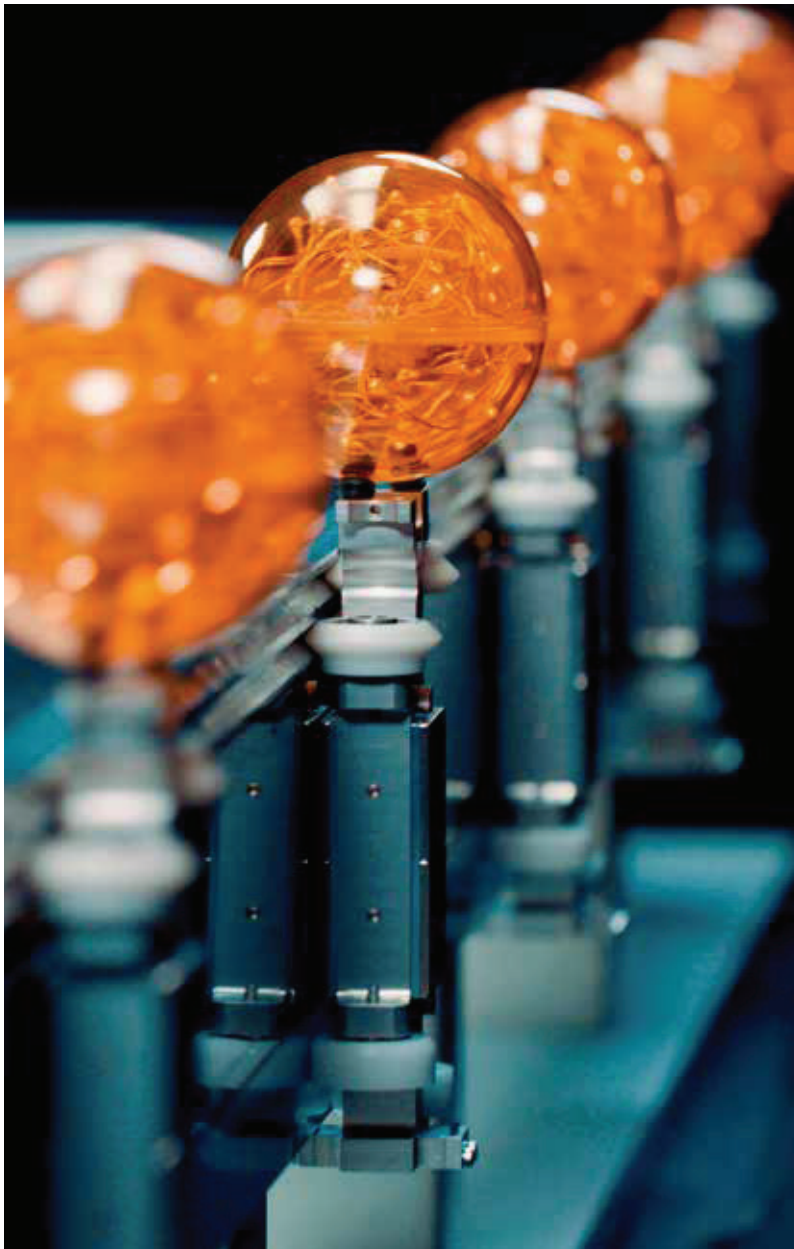

完美自动化

# 目录

ACOPOStrak .....	04
SuperTrak .....	12
轨道技术应用案例 .....	20

# ACOPOStrak





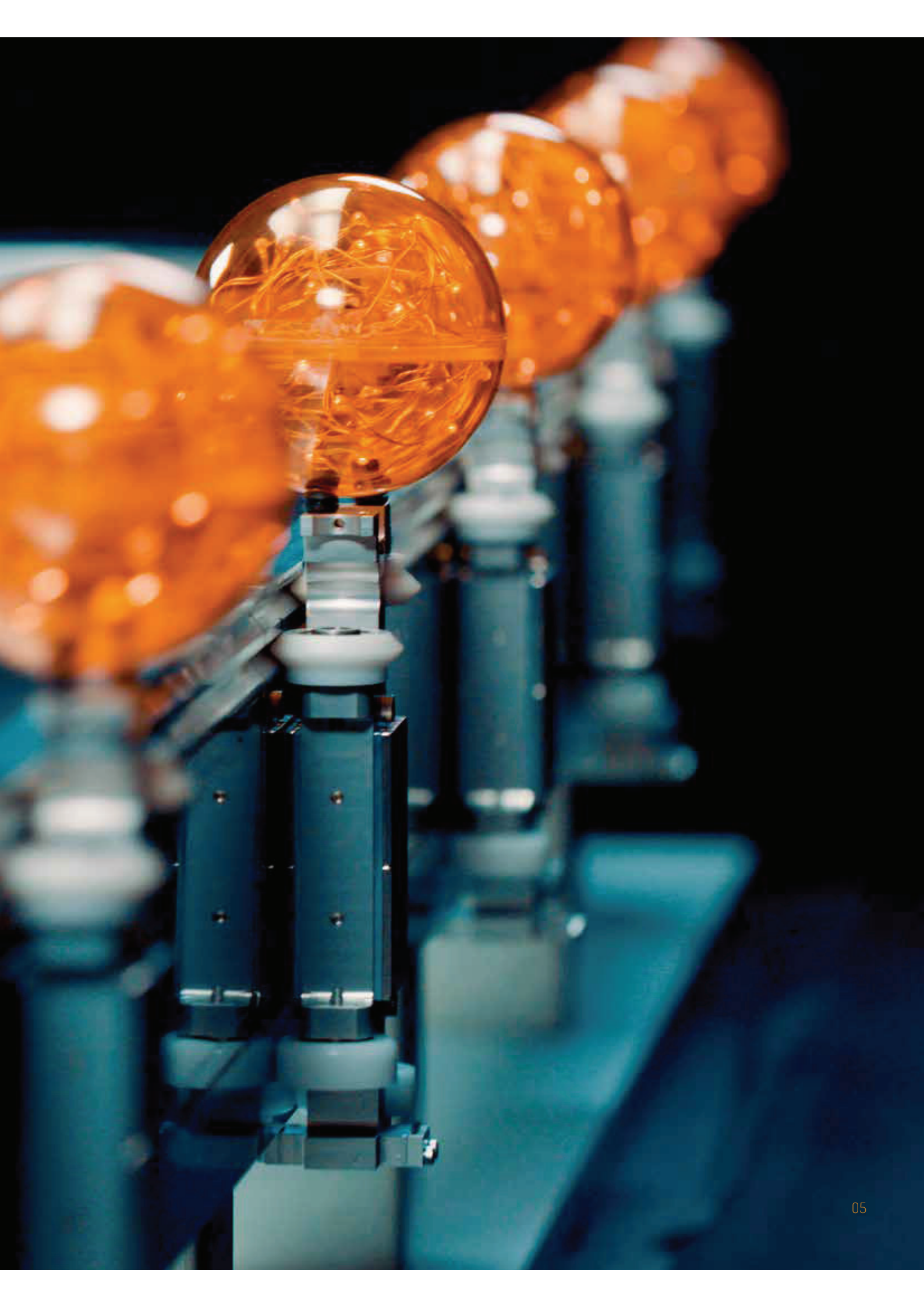

# 为柔性制造赋能

实现终极生产效益  
缩短产品上市时间  
加快投资回报



ROI  
↑

生产率高



OEE  
↑

质量

产品分流



ROI  
↑

设备占地面积小

ACOPOStrak重新定义了生产经济和设备效率。ACOPOStrak的独特设计使您能够获取小批量柔性的附加值。



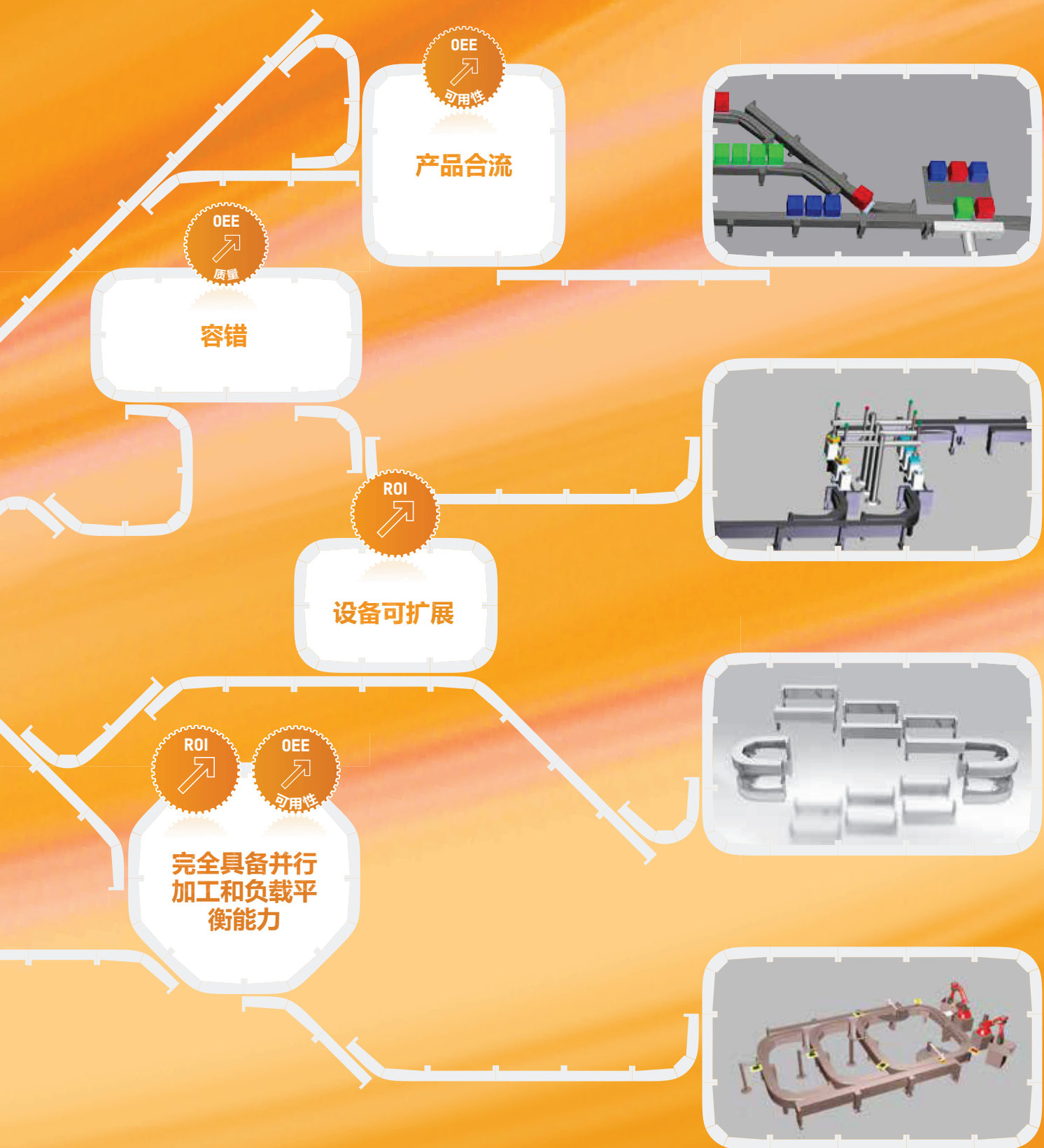

OEE  
↑  
可用性

产品合流

OEE  
↑  
质量

容错

ROI  
↑

设备可扩展

ROI  
↑

OEE  
↑  
可用性

完全具备并行  
加工和负载平  
衡能力

快速、柔性、高效

# 系统组件和轨道设计柔性



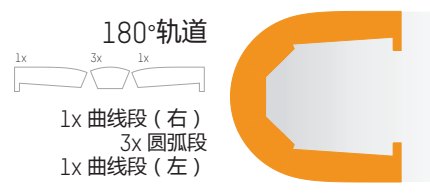
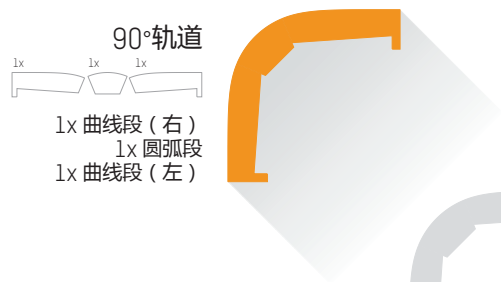
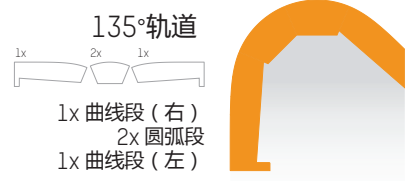



## 可变为任意形式

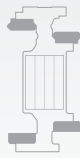

滑块



 轨道

滑块	直线导轨	45°	90°	135°	180°
					
轨道长度	660 mm	900 mm	1140 mm	1380 mm	1620 mm

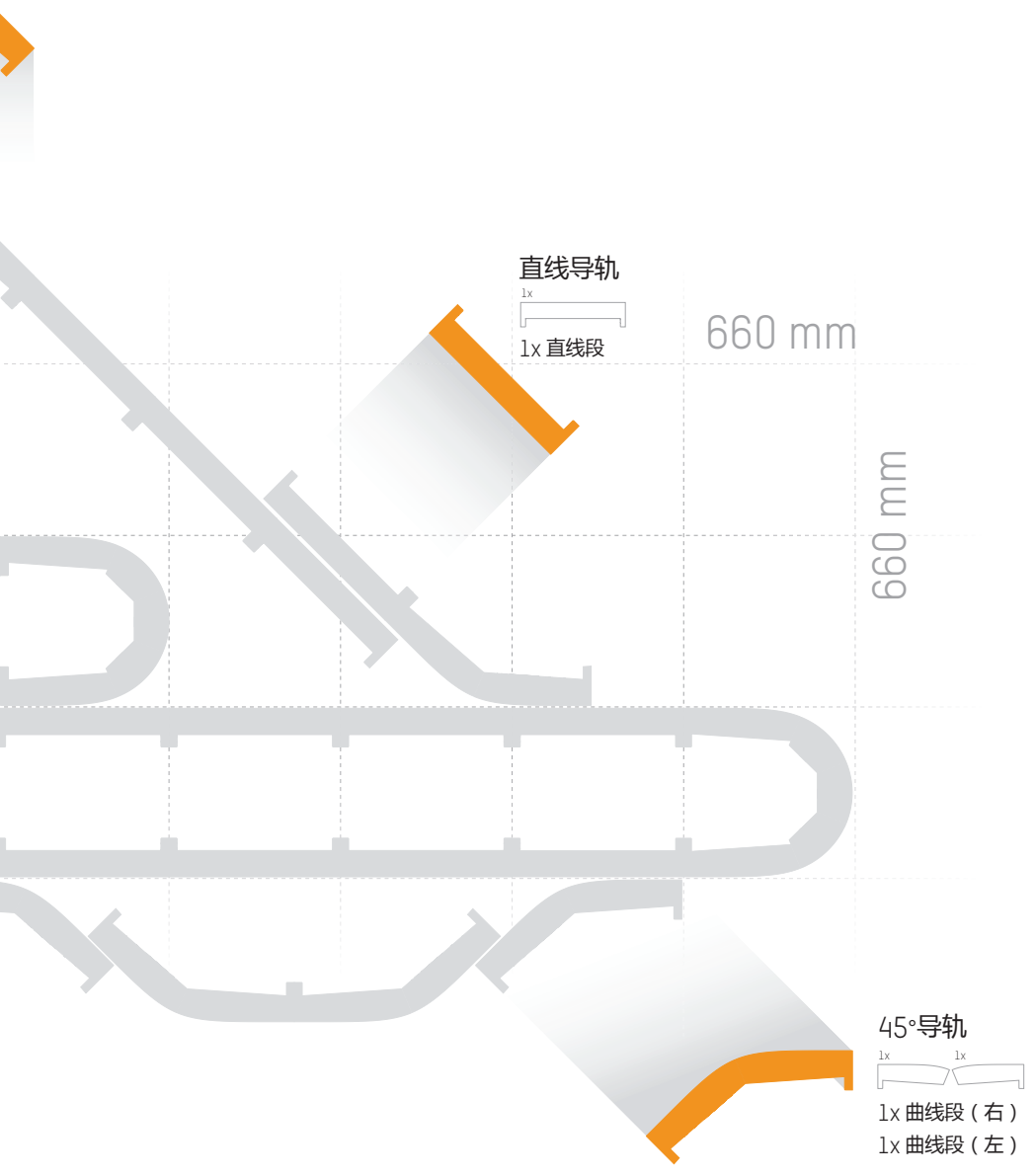

### 高速换向器



- 全电子换向技术
- 100%无磨损
- 全速实现产品分流和合流

### 轨道类型

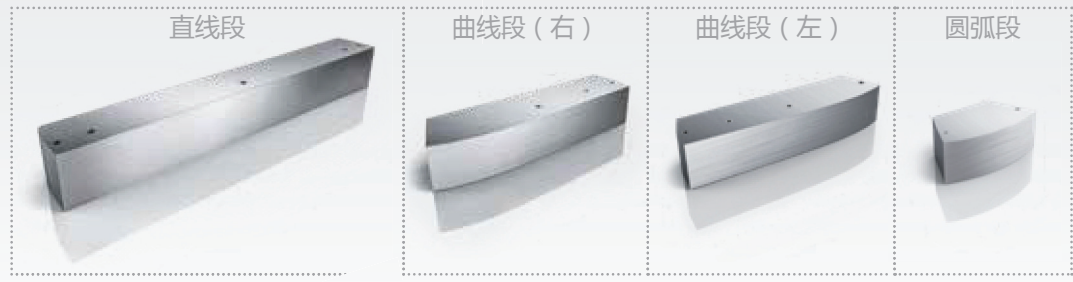

半径	305.58 mm		
角度	22.5°	45°	





ACOPOStrak →

技术数据和规格

轨道最大长度	> 100 m
滑块最大数量	> 250
产品最小间距	50 mm
速度	> 4 m/s
加速度	> 50 m/s <sup>2</sup>
直流母线电压	60 V
电机尺寸 (W x H)	80 mm x 85 mm
电机外壳和密封	不锈钢 (符合一次包装要求)
认证	CE, UL
安装方向	水平, 垂直, 任意倾角

智能化系统软件

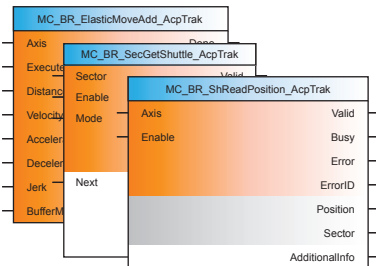
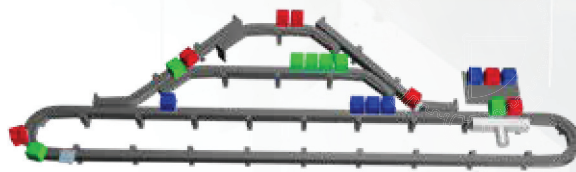
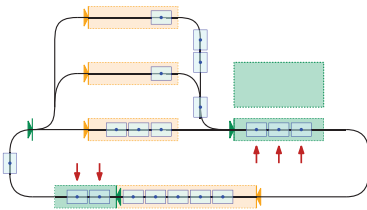

亮点

- 集成防碰撞功能的自主传输控制
- 广泛的仿真功能有利于加快产品上市

## 可热插拔的滑块



### 亮点

- 纯磁力吸持
- 快速换型
- 维修道用于换型和维保

## 洁净环境设计



### 亮点

- 不锈钢外壳
- 符合一次包装要求

## 系统拓扑

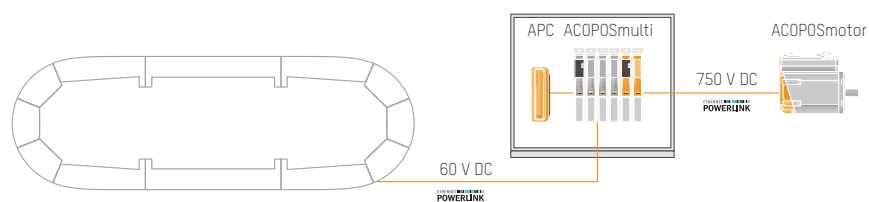

### 亮点

- 机柜空间小
- 集成电机/电子单元

# SuperTrak

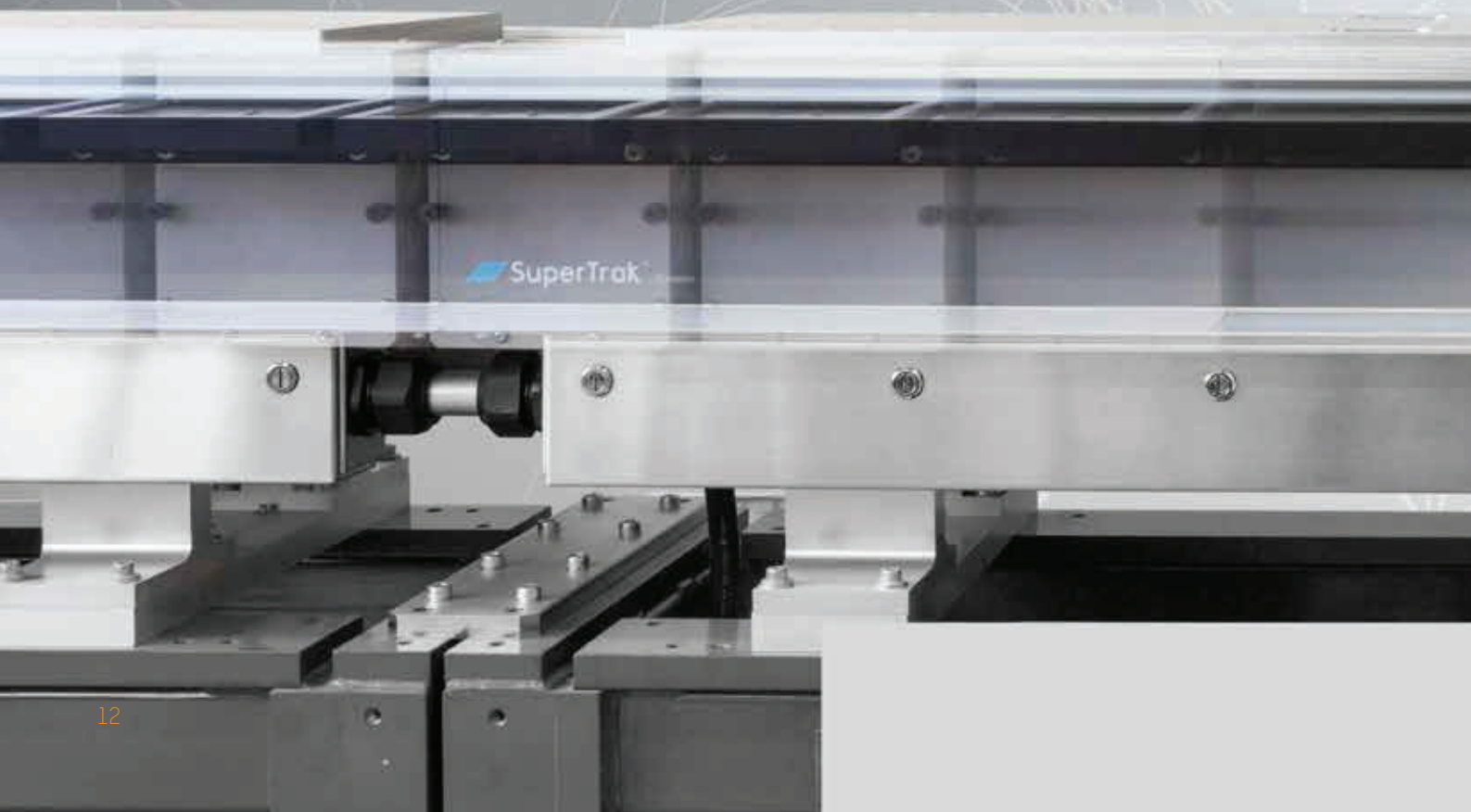





# 助力柔性制造

SuperTrak可实现任意批次柔性、高效生产的先进制造理念。

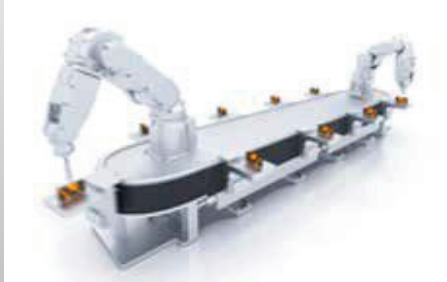

## 高度集成能力

- 可完美集成各类工业机器人
- 占用空间小

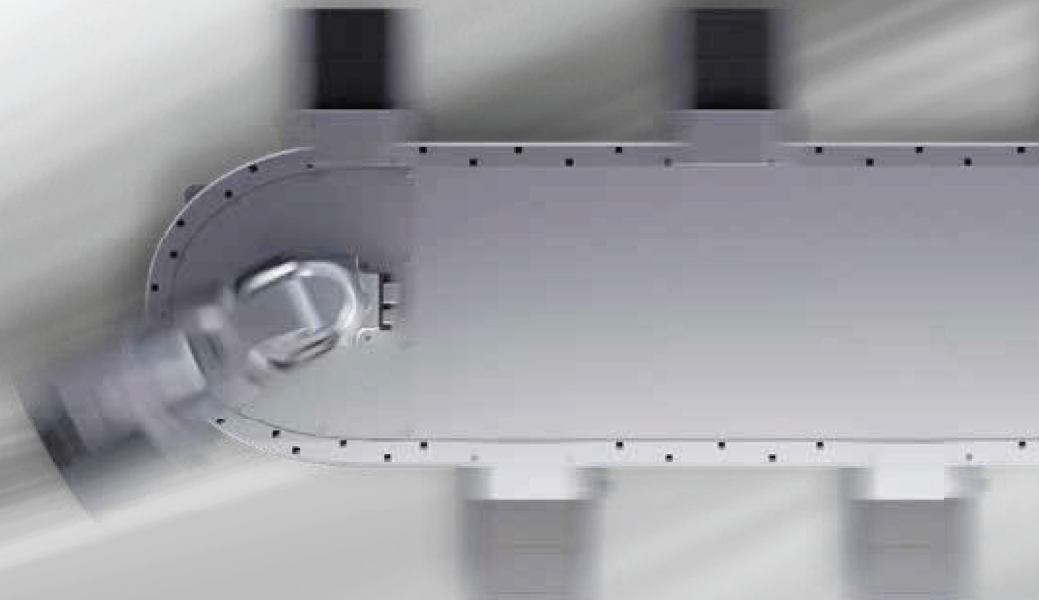

## 容错

- 可绕过不可用的工位继续操作
- 运行期间进行过程管理







## 高负载

- 可承受较高的加工受力
- 单个滑块载重量可达10千克

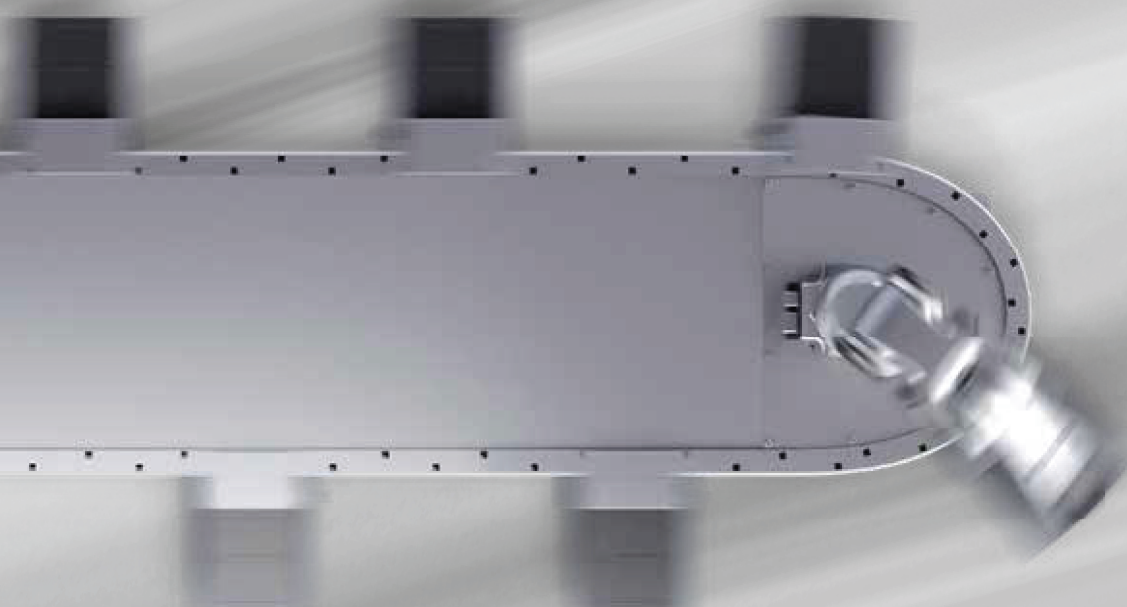

## 重复定位

- 高精度，提高生产质量
- 更快定位



可靠、坚固、精确



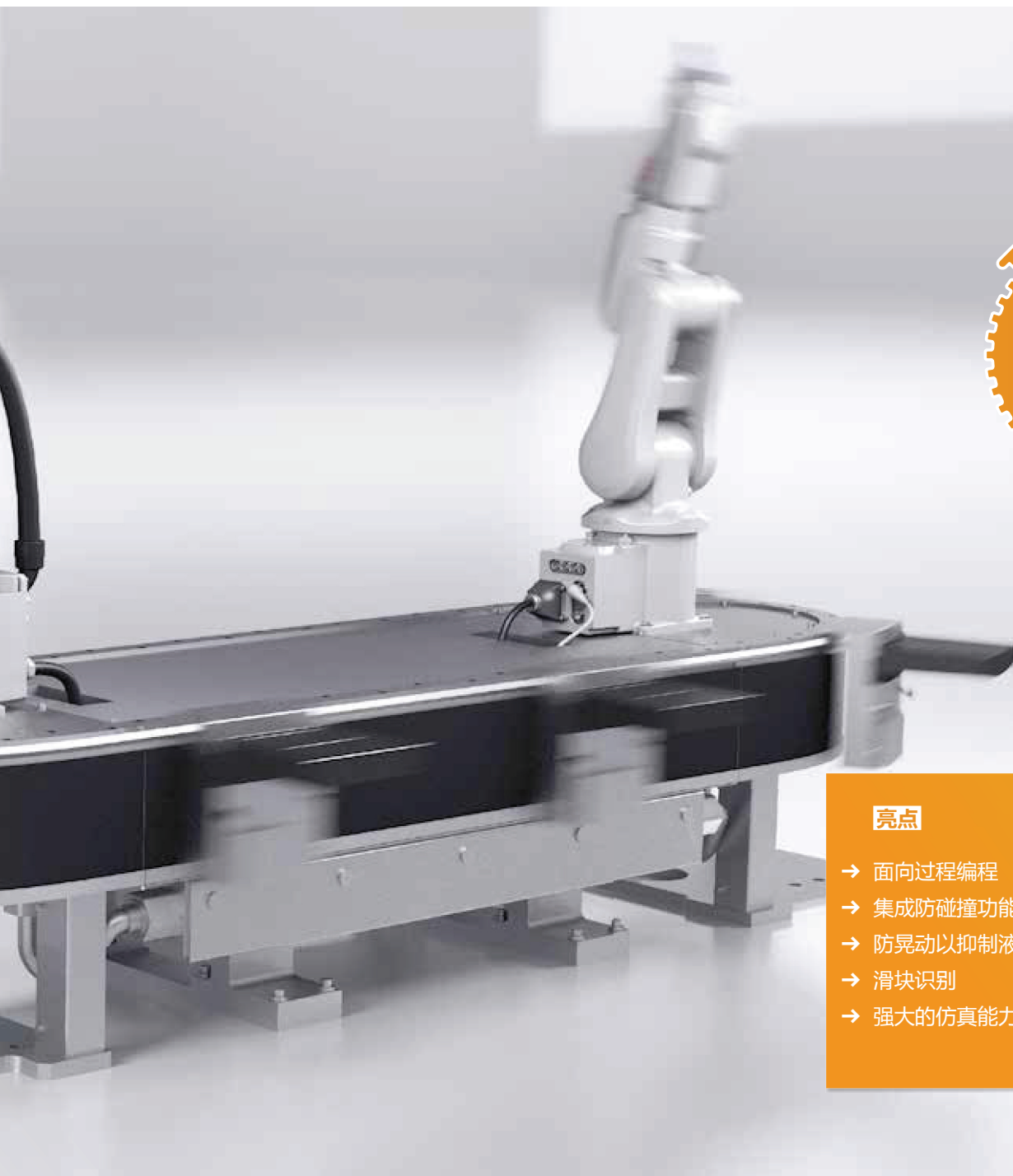

### 亮点

- 面向过程编程
- 集成防碰撞功能
- 防晃动以抑制液面振荡
- 滑块识别
- 强大的仿真能力，加快产品上市

## 滑块

- 长轴距，高稳定性
- 具有2或3个磁体
- 可选红外自动识别系统



曲线段



1030 mm



SuperTrak →

### 技术数据和规格

轨道最大长度	50 m
产品最小间距	152 mm
重复定位精度	+/- 10 μm
最大速度	4 m/s
加速度	>40 m/s <sup>2</sup>
最大推力	160 N
磁性吸持力	1290 N
最大载重	10+ kg
安装方向	水平、垂直

## 系统成熟度

### 工业验证过的可靠性

- 16年的现场经验
- 目前是其第三代产品
- 成功应用于众多行业

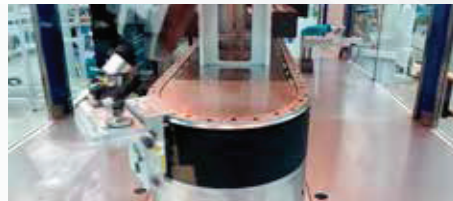

### 设计可靠性

- 最大限度减少移动部件数量
- 机械磨损小
- 平均维修时间小于1小时

### 易于维护

- 仅有四个组件需要定期更换
- 轨道和滚轮：正常运行中平均无故障时间大于16000小时





## 热插拔滑块

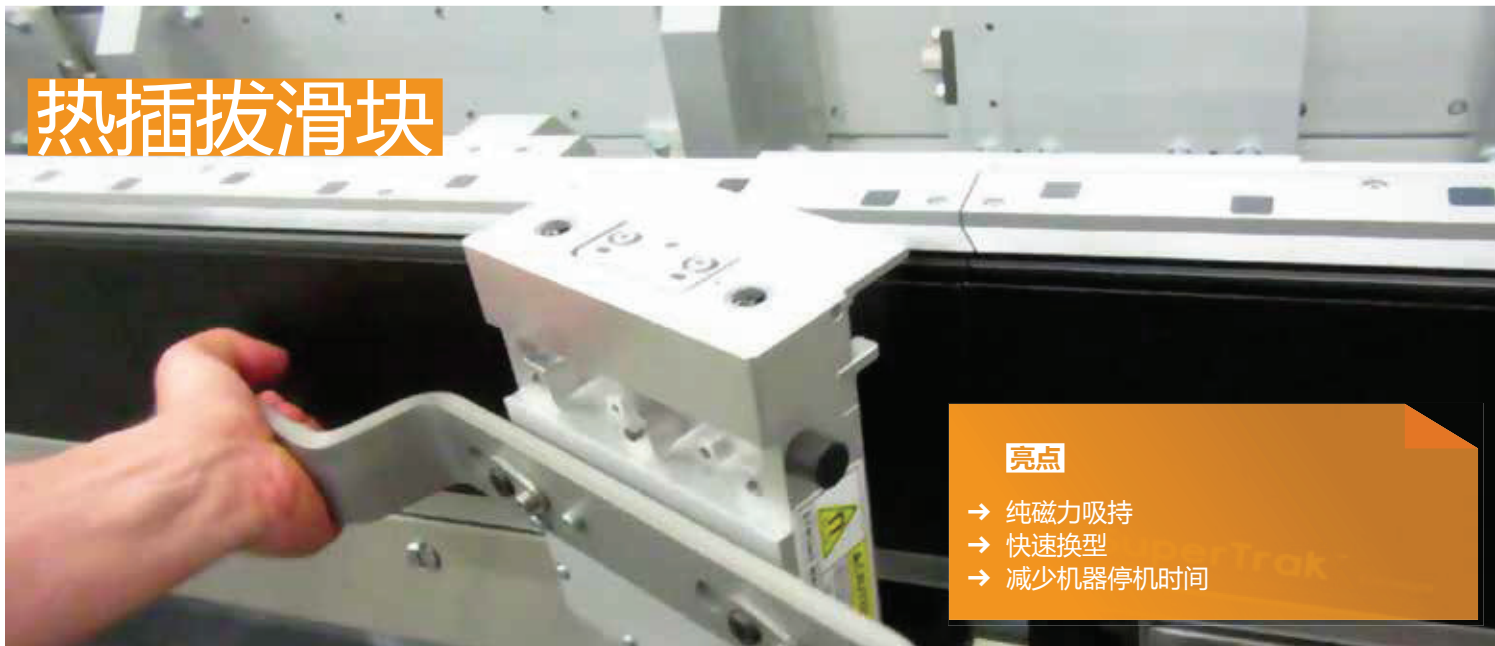

### 亮点

- 纯磁力吸持
- 快速换型
- 减少机器停机时间

## 完全集成CNC



### 亮点

- CNC组件有效集成到自动化生产单元中
- 系统具有高可用性

## 系统拓扑

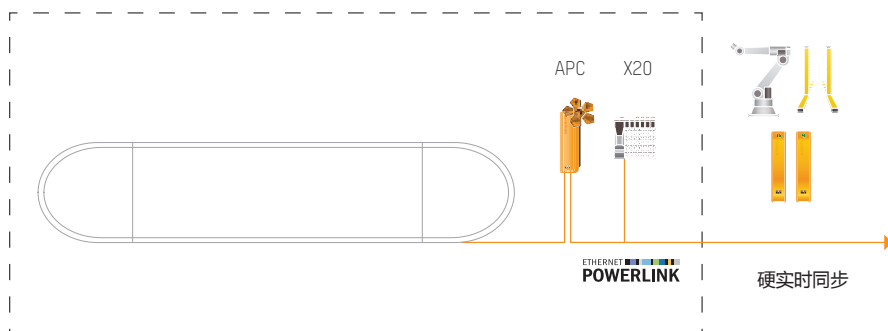

### 亮点

- 集成电机/驱动单元
- 第三方集成
- 与外部轴高精度同步



# 轨道技术应用案例





## 面向新一代消费者...



今天最具影响力的消费群体是**数字原生代** - 一代从来都不知道离线生活的人。

他们对个性化产品的需求，为**提高利润率和客户忠诚度**提供了巨大机会。

## ...新一代机械



为了从这种机会中获利，公司需要一种能够以**大规模生产**的效率来制造**定制化产品**的方法。

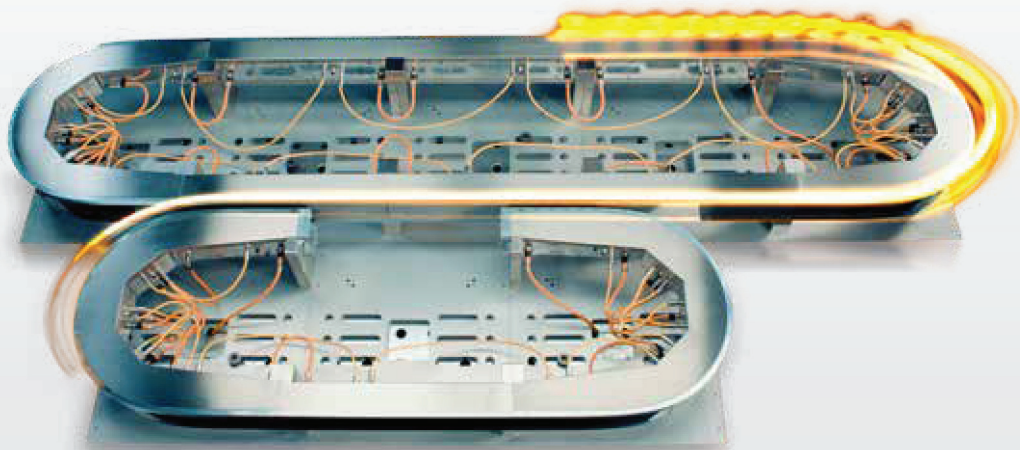



他们在**数字世界**的便利性和客制化服务中长大，已经形成了一系列与之相匹配的消费预期。



为了迎接这一挑战，我们看到了一种新型**柔性制造设备**。



**Track技术**是卓越柔性的来源，也是柔性制造的核心。放飞你的想象力，去自由驰骋地设计**柔性制造工艺**吧，**贝加莱Track技术**将您的想象转化为现实。

# 自适应机器

实现大规模定制  
开启新商业模式

快速、柔性、高效

ACOP0Strak

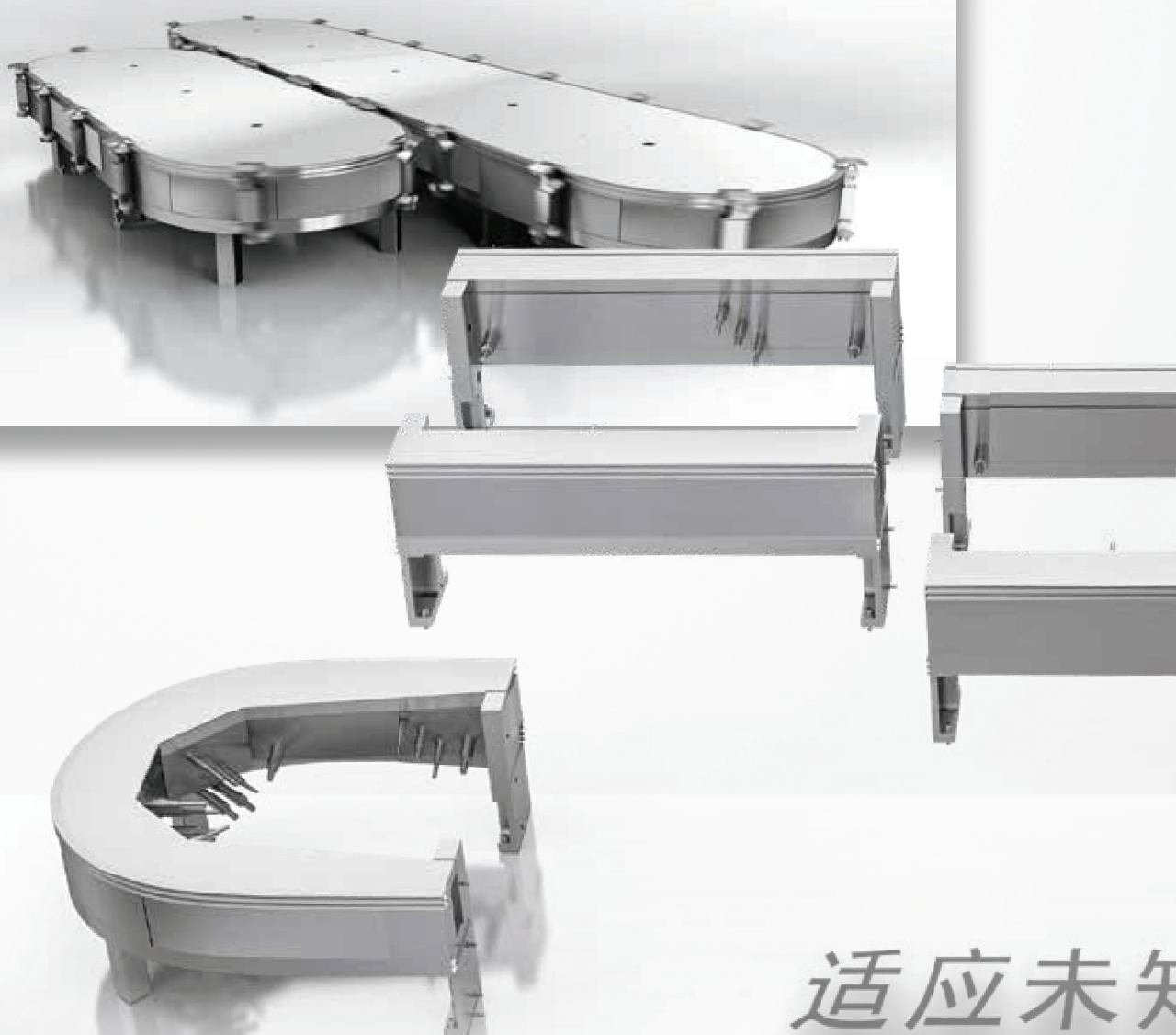

适应未知

每个产品独立处理和加工

内置容错

通过可复用的特点确  
保投资安全



可靠、坚固、精确

SuperTrak

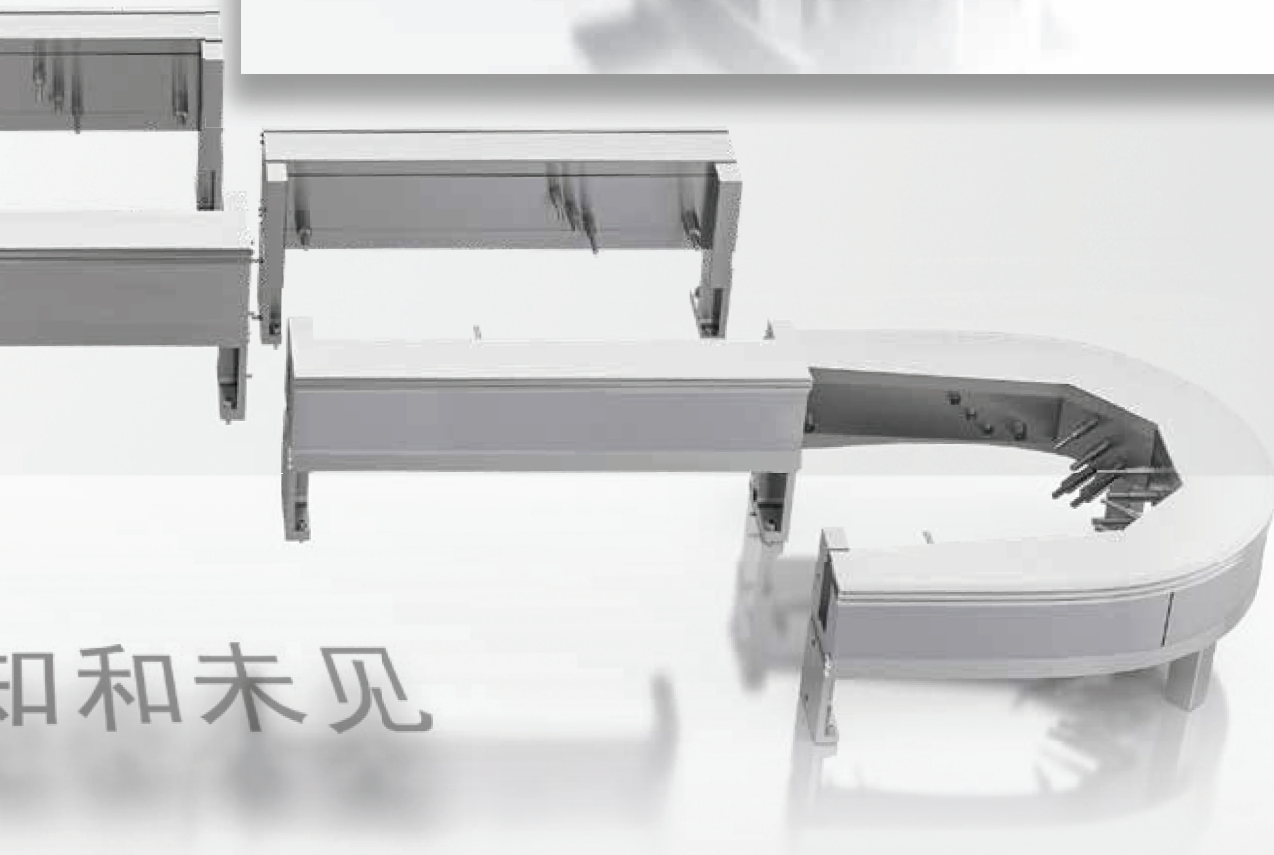
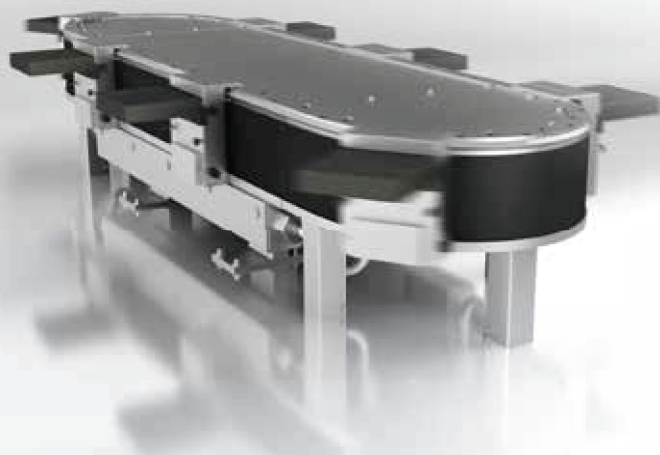

和未见

0换型时间

单位面积生产率更高

并行加工

# 您将如何向新消费者进行营销？



# 您所在行业的柔性产线机器

消费类电子产品



医疗器械和手术用品



香水和化妆品



糖果



食品/饮料加工和包装



服装和运动服



药房自动化



耳塞、助听器和听力保护装置



半成品餐盒



电池



汽车零部件



工业部件





# 集成自动化 服务全球 稳固的合作关系



ETHERNET   
**POWERLINK**

open   
**SAFETY**

全球总部  
B&R Industrial Automation GmbH  
B&R Strasse 1  
A-5142 Eggelsberg 奥地利  
Tel. : +43(0)7748/6586-0  
Fax : +43(0)7748/6586-26  
office@br-automation.com  
www.br-automation.com

貝加萊渠道合作夥伴  
巨緯科技股份有限公司  
桃園市龜山區頂湖三街39號  
Tel : +886-3-3288-171  
Fax: +886-3-3288-172  
chuwei.service@chuwei.tw  
<https://chuweitw.com/>



SuperTrak 簡介



巨緯科技股份有限公司