

ROBOTICS

Product specification

IRB 6700



Trace back information:
Workspace 21C version a2
Checked in 2021-09-23
Skribenta version 5.4.005

Product specification

IRB 6700-235/2.65
IRB 6700-205/2.80
IRB 6700-175/3.05
IRB 6700-150/3.20
IRB 6700-200/2.60
IRB 6700-155/2.85
IRB 6700-300/2.70
IRB 6700-245/3.00
IRB 6700Inv-300/2.60
IRB 6700Inv-245/2.90

IRC5

Document ID: 3HAC044265-001

Revision: T

The information in this manual is subject to change without notice and should not be construed as a commitment by ABB. ABB assumes no responsibility for any errors that may appear in this manual.

Except as may be expressly stated anywhere in this manual, nothing herein shall be construed as any kind of guarantee or warranty by ABB for losses, damage to persons or property, fitness for a specific purpose or the like.

In no event shall ABB be liable for incidental or consequential damages arising from use of this manual and products described herein.

This manual and parts thereof must not be reproduced or copied without ABB's written permission.

Keep for future reference.

Additional copies of this manual may be obtained from ABB.

Original instructions.

© Copyright 2021 ABB. All rights reserved.
Specifications subject to change without notice.

Table of contents

Overview of this product specification	7
1 Description	11
1.1 Structure	11
1.1.1 Introduction	11
1.1.2 Different robot versions	14
1.1.3 Definition of version designations	15
1.2 Standards	20
1.2.1 Applicable standards	20
1.3 Installation	22
1.3.1 Introduction to installation	22
1.3.2 Operating requirements	23
1.3.3 Assembling the manipulator	24
1.4 Calibration and references	31
1.4.1 Calibration methods	31
1.4.2 Fine calibration	33
1.4.3 Absolute Accuracy calibration	34
1.5 Load diagrams	37
1.5.1 Introduction	37
1.5.2 Diagrams	38
1.5.3 Maximum load and moment of inertia for full and limited axis 5 (center line down) movement	68
1.5.4 Wrist torque	70
1.5.5 Maximum TCP acceleration	71
1.6 Fitting equipment to the robot	72
1.7 Maintenance and troubleshooting	81
1.8 Robot motion	82
1.8.1 Robot motion	82
1.8.2 Performance according to ISO 9283	95
1.8.3 Velocity	97
1.8.4 Robot stopping distances and times	98
1.9 Cooling fan for axis 1 motor	99
1.10 Servo gun	100
1.10.1 Introduction	100
1.10.2 Stationary gun	101
1.10.3 Robot gun	102
1.10.4 Robot gun and track motion	103
1.10.5 Track motion	104
2 DressPack	105
2.1 Introduction	105
2.1.1 Included options	105
2.1.2 Product range	108
2.1.3 Limitations of robot movements	109
2.1.4 Impact on MH3 DressPack lifetime	110
2.1.5 Information structure	111
2.2 DressPack	112
2.2.1 Introduction	112
2.2.2 Built-in features for upper arm DressPack	113
2.2.3 Interface descriptions for DressPack	114
2.2.4 Dimensions	120
2.3 Type H/HSe	122
2.3.1 Introduction	122
2.3.2 Configuration result for Type H HSe	124
2.3.3 Summary common options Type H HSe	129
2.3.4 Summary options required for Type HSe	130

Table of contents

2.4	Type Se	131
2.4.1	Introduction	131
2.4.2	Configuration result for Type Se	133
2.4.3	Summary common options for Type Se	142
2.5	Connection kits	143
2.5.1	Base - Connector kits	144
2.5.2	Axis 3 - Connector kits	146
2.5.3	Axis 6 - Connector kits	147
3	Specification of variants and options	149
3.1	Introduction to variants and options	149
3.2	Manipulator	150
3.3	Equipment	155
3.4	Floor cables	157
3.5	Process DressPack	158
3.6	DressPack floor cables	159
3.7	DressPack Lower and Upper arm	160
3.8	Connection kits	161
3.9	Servo Gun	162
3.10	User documentation	163
4	Accessories	165
4.1	Introduction to accessories	165
Index		167

Overview of this product specification

About this product specification

This product specification describes the performance of the manipulator or a complete family of manipulators in terms of:

- The structure and dimensional prints
- The fulfilment of standards, safety, and operating equipment
- The load diagrams, mounting or extra equipment, the motion, and the robot reach
- The specification of available variants and options

The specification covers the manipulator using the IRC5 controller.

Usage

Product specifications are used to find data and performance about the product, for example to decide which product to buy. How to handle the product is described in the product manual.

The specification is intended for:

- Product managers and product personnel
- Sales and marketing personnel
- Order and customer service personnel

References

Reference	Document ID
<i>Product specification - Controller IRC5</i> IRC5 with main computer DSQC1000.	3HAC047400-001
<i>Product specification - Controller software IRC5</i> IRC5 with main computer DSQC1000 and RobotWare 5.6x.	3HAC050945-001
<i>Product specification - Controller software IRC5</i> IRC5 with main computer DSQC1000 and RobotWare 6.	3HAC050945-001
<i>Product manual - IRB 6700</i>	3HAC044266-001
<i>Product manual - IRB 6700Inv</i>	3HAC058254-001
<i>Product specification - Robot user documentation, IRC5 with RobotWare 6</i>	3HAC052355-001

Revisions

Revision	Description
-	First release
A	<ul style="list-style-type: none"> • The variants IRB 6700-200/2.60 and IRB 6700-155/2.85 are added. • Minor corrections/updates
B	<ul style="list-style-type: none"> • DressPack & SpotPack updated
C	<ul style="list-style-type: none"> • Text for Foundry Plus updated. • Two variants added, IRB 6700-300/2.70 and IRB 6700-245/3.00. • Minor corrections/update

Continues on next page

Overview of this product specification

Continued

Revision	Description
D	<ul style="list-style-type: none"> AbsAcc data added New loads for IRB 6700-300 and -245 added Values for power consumption, brakes engaged/disengaged added Tightening torque for robot adjusted The use of guide pins for robot base added Updated data (ISO, weight) for IRB 6700-200 and IRB 6700-155
E	<ul style="list-style-type: none"> Minor corrections/update Updated standard tool flange drawing Guide pins for base plate changed to two cylindrical
F	<ul style="list-style-type: none"> Information regarding warranty for upper arm dress pack added. Minor corrections/update Section <i>SpotWelding cabinet</i> updated.
G	<ul style="list-style-type: none"> Warranty information for DressPack updated. Dimensions (measure D), for products -150/3.20 and -205/2.80 in table <i>Holes for fitting extra equipment</i> are changed from 400 mm to 500 mm. Illustration in section <i>Fastening holes robot base</i> is updated regarding guide holes. Illustration regarding centering diameters on tool flange updated.
H	<p>Published in release R17.1. The following updates are done in this revision:</p> <ul style="list-style-type: none"> Illustration for <i>Tool flange, standard</i> is updated. Major structural change is made on chapter <i>Specifications of variants and options</i>. IRB 6700Inv is added. Restriction of load diagram added. Working range axis 2 and 3 added.
J	<p>Published in release R17.2. The following updates are done in this revision:</p> <ul style="list-style-type: none"> Updated list of applicable standards. Delete option 828-1, 828-2, 768-3 and 782-1 as they were all phased out. 635-1,3,4,5 option phased out and replaced by 636-6. Type HS and S are phased out. 782-7, 796-1 phased out.
K	<p>Published in release R18.1. The following updates are done in this revision:</p> <ul style="list-style-type: none"> Water and air unit updated.
L	<p>Published in release R18.2. The following updates are done in this revision:</p> <ul style="list-style-type: none"> Customer signal wire information for Type H/HSe Ethernet updated.
M	<p>Published in release 19B. The following updates are done in this revision:</p> <ul style="list-style-type: none"> Minor corrections/updates Updated information about <i>Absolute Accuracy</i>.
N	<p>Published in release 19C. The following updates are done in this revision:</p> <ul style="list-style-type: none"> Updated option description of Extended working range. Note added about need to calibrate if the robot is other than floor mounted. See Calibration methods on page 31. Graphics for DressPack updated. See Base on page 115
P	<p>Published in release 20A. The following updates are done in this revision:</p> <ul style="list-style-type: none"> M8 cable lug description added in DressPack section.

Continues on next page

Revision	Description
Q	Published in release 20C. The following updates are done in this revision: <ul style="list-style-type: none">• Made minor changes in Dresspack section.
R	Published in release 20D. The following updates are done in this revision: <ul style="list-style-type: none">• Warranty section updated
S	Published in release 21A. The following updates are done in this revision: <ul style="list-style-type: none">• Minor changes
T	Published in release 21C The following updates are done in this revision: <ul style="list-style-type: none">• Text regarding fastener quality is updated.• Removed Axis resolution.• Updated information about the option <i>Extended working range</i>.• Removed option (SpotPack phase out) 782-13 Bosch MFDC ProfiNet, 858-1 Bosch Adaptive control, 788-1 Forced air cooling, 789-1 Earth fault protection unit, 790-1 Contactor for weld power, 791-1 Weld power cable, 7 m, 791-2 Weld power cable, 15 m, 809-1 process cable to stationary gun, 7 m, 809-2 process cable to stationary gun, 15 m, 792-1 Type S, 792-2 Type HS, 793-1 Second water return, 797-1 7m, 797-2 15m, 797-3 22m, 797-4 30m.

This page is intentionally left blank

1 Description

1.1 Structure

1.1.1 Introduction

General

The IRB 6700 series is ABB Robotics 7th generation of high payload, high performance industrial robots. Based on the famous IRB 6640 series, with large working range, the very high wrist torque, the service friendly modular built up and the availability, significant for ABB's robots, the IRB 6700 robot family goes even further. With focus on high production capacity, compact design and low weight, simple service and low maintenance cost. The IRB 6700 is ideal for process applications, regardless of industry. Typical areas are for example Spot Welding, Material Handling and Machine Tending.

Software product range

We have added a range of software products - all falling under the umbrella designation of Active Safety - to protect not only personnel in the unlikely event of an accident, but also robot tools, peripheral equipment and the robot itself.

Options

There are a large number of options for material handling and spot welding integrated in the robot. For a complete description of Material handling see [DressPack on page 105](#).

Operating system

The robot is equipped with the IRC5 controller and robot control software, RobotWare. RobotWare supports every aspect of the robot system, such as motion control, development and execution of application programs, communication etc. See *Product specification - Controller IRC5*.

Safety

Safety standards valid for complete robot, manipulator and controller.

Additional functionality

For additional functionality, the robot can be equipped with optional software for application support - for example gluing and welding, communication features - network communication - and advanced functions such as multitasking, sensor control etc. For a complete description on optional software, see the *Product specification - Controller IRC5*.

Protection type Foundry Plus 2

Robots with the option Foundry Plus 2 are designed for harsh environments where the robot is exposed to sprays of coolants, lubricants and metal spits that are typical for die casting applications or other similar applications.

Continues on next page

1 Description

1.1.1 Introduction

Continued

Typical applications are spraying insertion and part extraction of die-casting machines, handling in sand casting and gravity casting, etc. (Please refer to Foundry Prime robots for washing applications or other similar applications). Special care must be taken in regard to operational and maintenance requirements for applications in foundry as well as in other applications areas. Please contact ABB Robotics Sales organization if in doubt regarding specific application feasibility for the Foundry Plus 2 protected robot.

The robot is painted with two-component epoxy on top of a primer for corrosion protection. To further improve the corrosion protection additional rust preventive are applied to exposed and crucial areas, e.g. has the tool flange a special preventive coating. Although, continuous splashing of water or other similar rust formation fluids may cause rust attach on the robots unpainted areas, joints, or other unprotected surfaces. Under these circumstances it is recommended to add rust inhibitor to the fluid or take other measures to prevent potential rust formation on the mentioned.

The entire robot is IP67 compliant according to IEC 60529 - from base to wrist, which means that the electrical compartments are sealed against water and solid contaminants. Among other things all sensitive parts are better protected than the standard offer.

Selected Foundry Plus 2 features:

- Improved sealing to prevent penetration into cavities to secure IP67
- Additional protection of cabling and electronics
- Special covers that protect cavities
- Well-proven connectors
- Nickel coated tool flange
- Rust preventives on screws, washers and unpainted/machined surfaces
- Extended service and maintenance program

The Foundry Plus 2 robot can be cleaned with appropriate washing equipment according to the robot product manual. Appropriate cleaning and maintenance is required to maintain the protection, for example can rust preventive be washed off with wrong cleaning method.

Available robot versions

The option Foundry Plus 2 might not be available for all robot versions.

See [Specification of variants and options on page 149](#) for robot versions and other options not selectable together with Foundry Plus 2.

Continues on next page

Robot axes

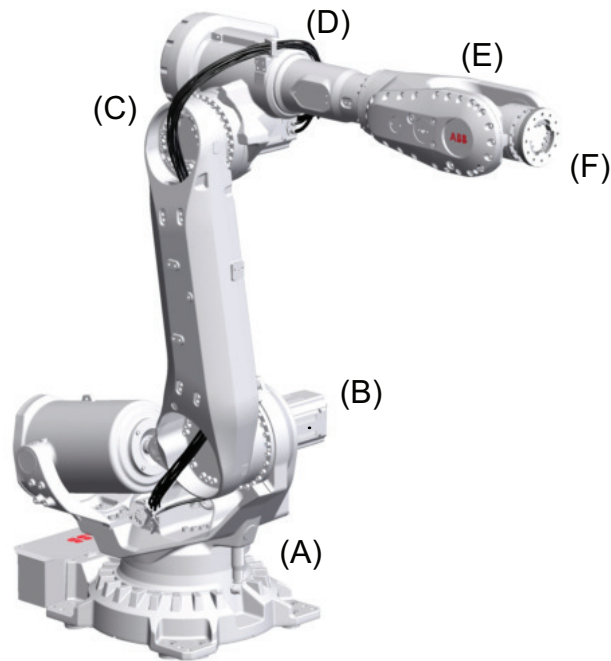

xx130000244

Pos	Description	Pos	Description
A	Axis 1	B	Axis 2
C	Axis 3	D	Axis 4
E	Axis 5	F	Axis 6

1 Description

1.1.2 Different robot versions

1.1.2 Different robot versions

General

The IRB 6700 is available in ten versions.

Robot types

The following standard robot versions are available.

Robot type	Handling capacity (kg)	Handling capacity for LeanID (kg)	Reach (m)
IRB 6700	235 kg	220 kg	2.65 m
IRB 6700	205 kg	200 kg	2.80 m
IRB 6700	200 kg	175 kg	2.60 m
IRB 6700	175 kg	155 kg	3.05 m
IRB 6700	155 kg	140 kg	2.85 m
IRB 6700	150 kg	145 kg	3.20 m
IRB 6700	300 kg	270 kg	2.70 m
IRB 6700	245 kg	220 kg	3.00 m
IRB 6700Inv	300 kg	270 kg	2.60 m
IRB 6700Inv	245 kg	210 kg	2.90 m



Note

If option 780-4, LeanID is selected, the payload will decrease as stated above, for detailed information see [Load diagrams on page 37](#)

1.1.3 Definition of version designations

Manipulator weight

Robot type	Weight ¹
IRB 6700-235/2.65	1250 kg
IRB 6700-205/2.80	1260 kg
IRB 6700-200/2.60	1205 kg
IRB 6700-175/3.05	1270 kg
IRB 6700-155/2.85	1220 kg
IRB 6700-150/3.20	1280 kg
IRB 6700-300/2.70	1525 kg
IRB 6700-245/3.00	1540 kg
IRB 6700INV-300/2.60	1690 kg
IRB 6700INV-245/2.90	1705 kg

Other technical data

Data	Description	Note
Airborne noise level	The sound pressure level outside the working space.	< 71 dB (A) Leq (acc. to machinery directive 2006/42/EG)

Power consumption at max load

Type of movement	235/2.65	205/2.80	200/2.60	175/3.05	155/2.85	150/3.20	300/2.70	245/3.00	INV 300/2.60	INV 245/2.90
ISO Cube Max. velocity (kW)	2.9	2.6	2.6	2.8	2.7	2.7	3.4	3.2	3.4	3.3
Robot in calibration position	235/2.65	205/2.80	200/2.60	175/3.05	155/2.85	150/3.20	300/2.70	245/3.00	INV 300/2.60	INV 245/2.90
Brakes engaged (kW)	0.16	0.17	0.15	0.16	0.15	0.16	0.15	0.15	0.17	0.17
Brakes disengaged (kW)	0.71	0.84	0.62	0.82	0.69	0.77	0.79	0.75	1.06	0.99

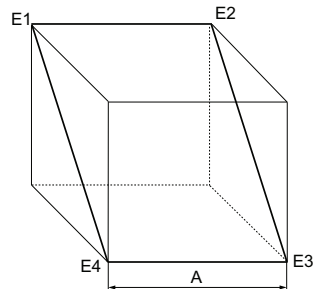

xx100000101

¹ Manipulator weight

Continues on next page

1 Description

1.1.3 Definition of version designations

Continued

Pos	Description
A	1,000 mm

Continues on next page

Main dimensions of IRB 6700

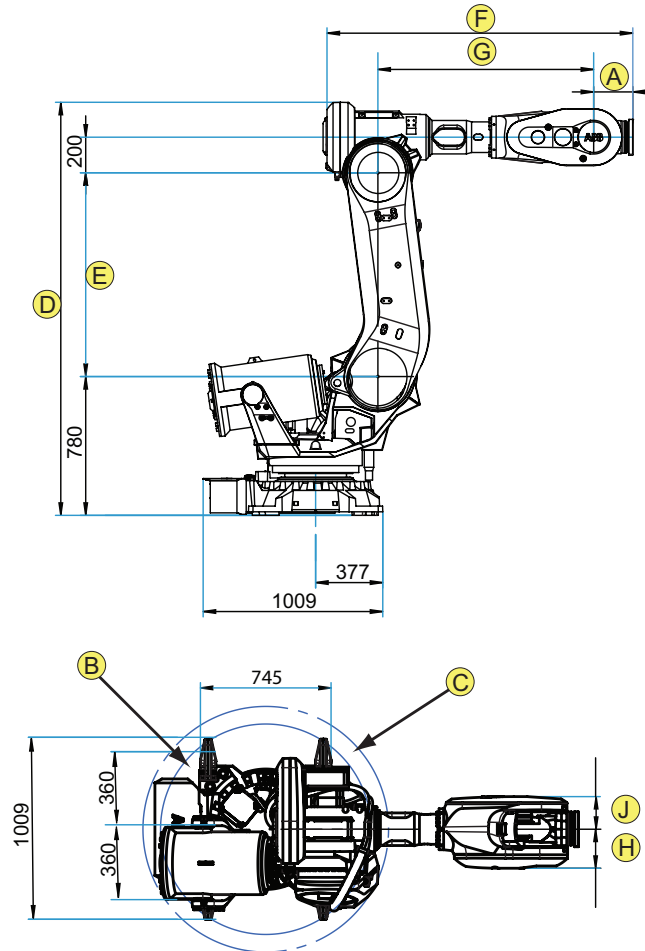

xx130000241

Pos	Description
A	200 mm (all standard variants); except 300/2.70 and 245/3.00 =220 mm 350 mm (all LeanID variants, option 780-4); except IRB 300/2.70 and 245/3.00 = 380 mm
B	Radius ax1, front = 532 mm (IRB 6700-235/2.65, -205/2.80, -175/3.05, -150/3.20, -200/2.60 and -155/2.85) Radius ax1, front = 600 mm (IRB 6700-300/2.70 and -245/3.00)
C	Radius ax1, back = 633 mm (IRB 6700-235/2.65, -220/2.65 LID, -205/2.80, -200/2.80 LID, -175/3.05, -155/3.05 LID, -150/3.20, -145/3.20 LID, -200/2.60, -175/2.60 LID, -155/2.85 and 140/2.85 LID)

Robot variant	D	E	F	G	H	J
IRB 6700 - 235/2.65	2300	1135	1670	1182.5	209	186
IRB 6700 - 205/2.80	2445	1280	1670	1182.5	186	209
IRB 6700 - 200/2.60	2276	1125	1623	1,142.5	197.5	193
IRB 6700 - 175/3.05	2300	1135	2080	1,592.5	209	186
IRB 6700 - 150/3.20	2445	1280	2080	1592.5	209	186
IRB 6700 - 155/2.85	2276	1125	1873	1,392.5	197.5	193

Continues on next page

1 Description

1.1.3 Definition of version designations

Continued

Robot variant	D	E	F	G	H	J
IRB 6700 - 300/2.70	2321	1145	1718.5	1212.5	222.5	187
IRB 6700 - 245/3.00	2321	1145	1968.5	1462.5	222.5	186



Note

For DressPack dimensions, see [Dimensions for robot with DressPack on page 120](#)

Continues on next page

Main dimensions of IRB 6700 inverted variants

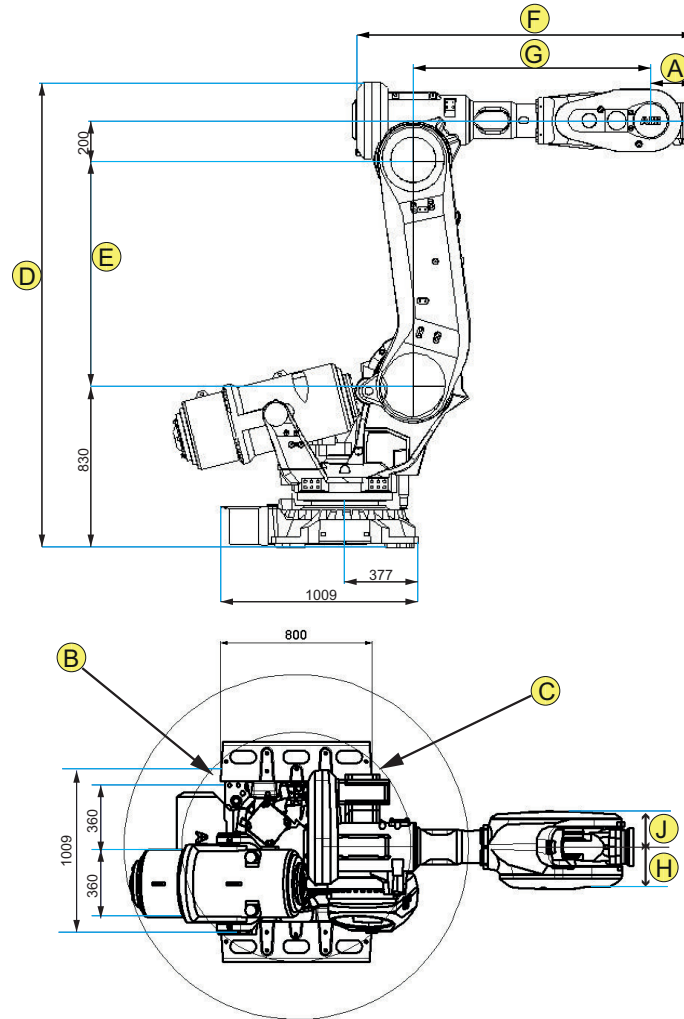

xx170000559

Pos	Description
A	220 mm (all IRB 6700Inv variants) 380 mm (all IRB 6700Inv LeanID variants) option 780-4
B	Radius ax1, front = 626 mm
C	Radius ax1, back = 910 mm

Robot variant	D	E	F	G	H	J
IRB 6700Inv - 300/2.60	2372	1145	1718.5	1212.5	222.5	187
IRB 6700Inv - 245/2.90	2372	1145	1968.5	1468.5	222.5	186

1 Description

1.2.1 Applicable standards

1.2 Standards

1.2.1 Applicable standards



Note

The listed standards are valid at the time of the release of this document. Phased out or replaced standards are removed from the list when needed.

General

The product is designed in accordance with ISO 10218-1:2011, Robots for industrial environments - Safety requirements -Part 1 Robots, and applicable parts in the normative references, as referred to from ISO 10218-1:2011. In case of deviations from ISO 10218-1:2011, these are listed in the declaration of incorporation which is part of the product delivery.

Normative standards as referred to from ISO 10218-1

Standard	Description
ISO 9283:1998	Manipulating industrial robots - Performance criteria and related test methods
ISO 10218-2	Robots and robotic devices - Safety requirements for industrial robots - Part 2: Robot systems and integration
ISO 12100	Safety of machinery - General principles for design - Risk assessment and risk reduction
ISO 13849-1:2006	Safety of machinery - Safety related parts of control systems - Part 1: General principles for design
ISO 13850	Safety of machinery - Emergency stop - Principles for design
IEC 60204-1:2005	Safety of machinery - Electrical equipment of machines - Part 1: General requirements
IEC 62061:2005	Safety of machinery - Functional safety of safety-related electrical, electronic and programmable electronic control systems

Region specific standards and regulations

Standard	Description
ANSI/RIA R15.06	Safety requirements for industrial robots and robot systems
ANSI/UL 1740	Safety standard for robots and robotic equipment
CAN/CSA Z 434-14	Industrial robots and robot Systems - General safety requirements

Other standards used in design

Standard	Description
ISO 9787:2013	Robots and robotic devices -- Coordinate systems and motion nomenclatures
IEC 61000-6-2	Electromagnetic compatibility (EMC) – Part 6-2: Generic standards – Immunity standard for industrial environments

Continues on next page

Standard	Description
IEC 61000-6-4 (option 129-1)	Electromagnetic compatibility (EMC) – Part 6-4: Generic standards – Emission standard for industrial environments
ISO 13732-1:2006	Ergonomics of the thermal environment - Part 1
IEC 60974-1:2012 ⁱ	Arc welding equipment - Part 1: Welding power sources
IEC 60974-10:2014 ⁱ	Arc welding equipment - Part 10: EMC requirements
ISO 14644-1:2015 ⁱⁱ	Classification of air cleanliness
IEC 60529:1989 + A2:2013	Degrees of protection provided by enclosures (IP code)

ⁱ Only valid for arc welding robots. Replaces IEC 61000-6-4 for arc welding robots.

ⁱⁱ Only robots with protection Clean Room.

1 Description

1.3.1 Introduction to installation

1.3 Installation

1.3.1 Introduction to installation

General

IRB 6700 are designed for floor mounting (no tilting allowed around X-axis or Y-axis). IRB 6700Inv variants are designed for inverted mounting (no tilting allowed around X-axis or Y-axis). Depending on the robot version, an end effector with max. weight of 150 to 300 kg including payload, can be mounted on the tool flange (axis 6). See [Load diagrams on page 37](#).

Extra loads

Extra load (valve packages, transformers, DressPack) of 50 kg, which is included in the load diagrams, can be mounted on the upper arm. An extra load of 250 kg can also be mounted on the frame of axis 1.

See [Fitting equipment to the robot on page 72](#).

Working range limitation

The working range of axes 1 can be limited by mechanical stops as option. See [Working range limitation on page 153](#).

1.3.2 Operating requirements

Protection standards

Robot version/Protection standard	IEC 60529
All variants, manipulator	IP67

Explosive environments

The robot must not be located or operated in an explosive environment.

Ambient temperature

Description	Standard/Option	Temperature
Manipulator during operation	Standard	Minimum: +5 °C ⁱ (41 °F) Maximum: +50 °C (122 °F)
For the controller	Standard/Option	See <i>Product specification - Controller IRC5</i>
Complete robot during transportation and storage,	Standard	Minimum: -25 °C (-13 °F) Maximum: +55 °C (+131 °F)
for short periods (not exceeding 24 hours)	Standard	+70 °C (+158 °F)

ⁱ At low environmental temperature (below 10 °C) a warm-up phase is recommended to be run with the robot. Otherwise there is a risk that the robot stops or runs with lower performance due to temperature dependent oil and grease viscosity.

Relative humidity

Description	Relative humidity
Complete robot during transportation and storage	Maximum 95% at constant temperature.
Complete robot during operation	Maximum 95% at constant temperature.

1 Description

1.3.3 Assembling the manipulator

1.3.3 Assembling the manipulator

Maximum load

Maximum load in relation to the base coordinate system.

Floor mounted

Force	Endurance load (in operation)	Max. load (emergency stop)
Force xy	$\pm 7.4 \text{ kN}^i / \pm 8.7 \text{ kN}^{ii}$	$\pm 19.8 \text{ kN}^i / \pm 21.8 \text{ kN}^{ii}$
Force z	$14.6 \pm 4.5 \text{ kN}^i / 18.0 \pm 5.4 \text{ kN}^{ii}$	$14.6 \pm 15.7 \text{ kN}^i / 18.0 \pm 17.4 \text{ kN}^{ii}$
Torque xy	$\pm 21.0 \text{ kNm}^i / \pm 24.9 \text{ kNm}^{ii}$	$\pm 37.1 \text{ kNm}^i / \pm 45.3 \text{ kNm}^{ii}$
Torque z	$\pm 5.0 \text{ kNm}^i / \pm 6.5 \text{ kNm}^{ii}$	$\pm 11.4 \text{ kNm}^i / \pm 15.5 \text{ kNm}^{ii}$

ⁱ Valid for IRB 6700-235, -205, -175, -150, -200, -155.

ⁱⁱ Valid for IRB 6700-300, -245.

Inverted Mounted

Force	Endurance load (in operation)	Max. load (emergency stop)
Force xy	$\pm 8.9 \text{ kN}^i$	$\pm 23.7 \text{ kN}^i$
Force z	$-22.1 \pm 6.6 \text{ kN}^i$	$-22.1 \pm 18.1 \text{ kN}^i$
Torque xy	$\pm 22.5 \text{ kNm}^i$	$\pm 45.4 \text{ kNm}^i$
Torque z	$\pm 6.5 \text{ kNm}^i$	$\pm 15.7 \text{ kNm}^i$

ⁱ Valid for IRB 6700Inv-300, -245.

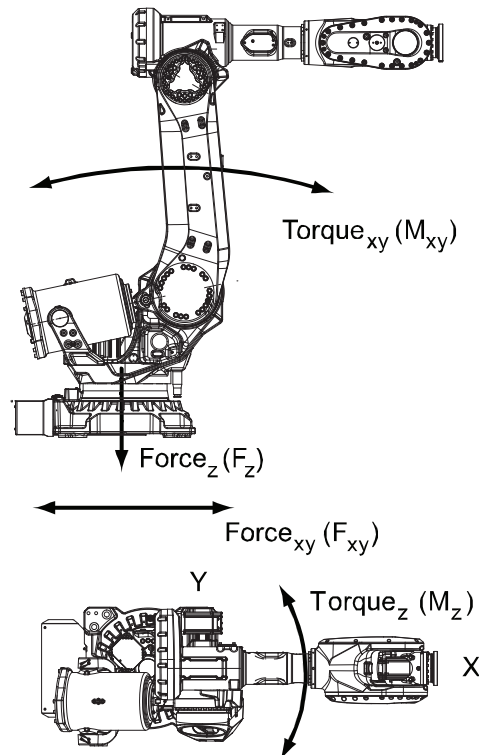

xx1300000242

Continues on next page

Note regarding M_{xy} and F_{xy}

The bending torque (M_{xy}) can occur in any direction in the XY-plane of the base coordinate system.

The same applies to the transverse force (F_{xy}).

Fastening holes robot base - for all variants

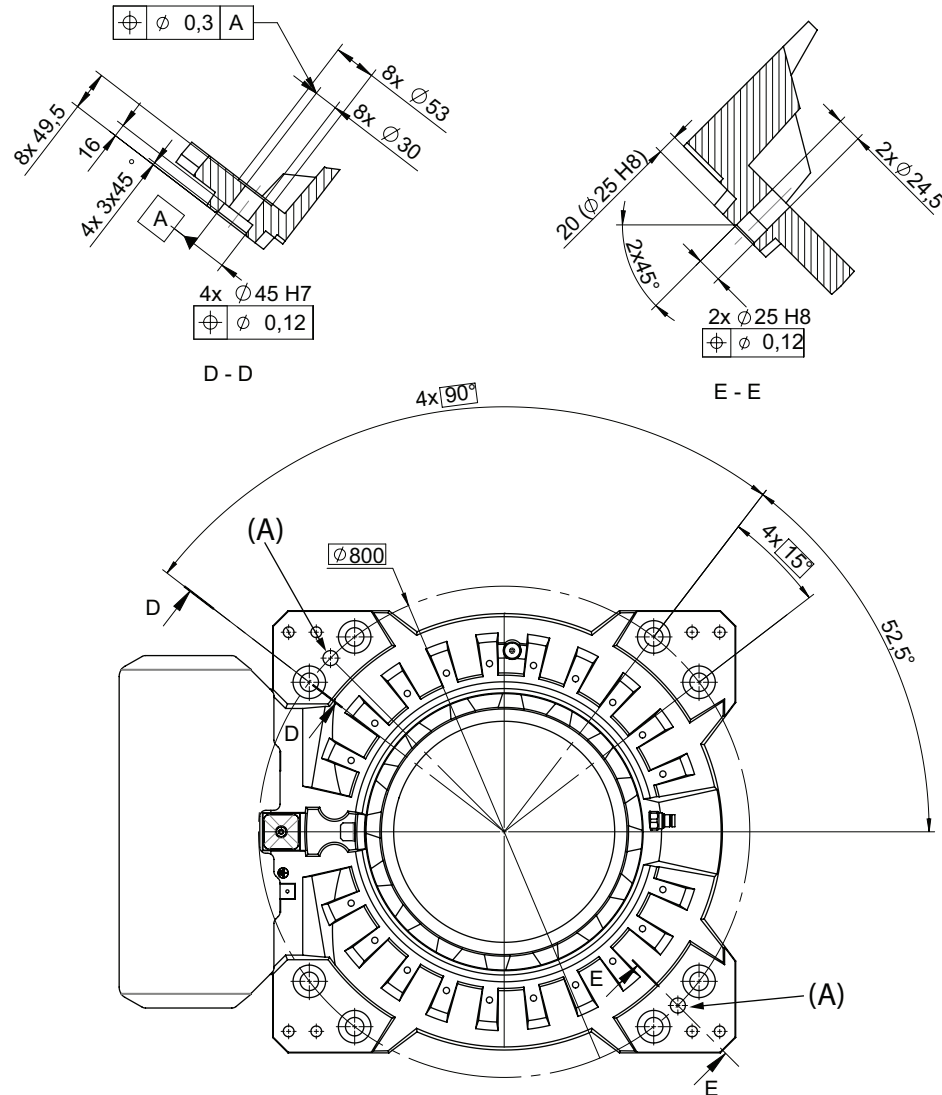

xx130000243

Pos	Description
A	Holes for guide pins (x2)



Note

Holes for guide pins (x2) Rear hole straight slot. See [Guide pins on page 30](#).

Continues on next page

1 Description

1.3.3 Assembling the manipulator

Continued

Fastener quality

Suitable screws:	M24 x 100 (installation on base plate/foundation)
Quality:	8.8
Screw tightening yield point utilization factor (v) (according to VDI2230):	90% (v=0.9)
Suitable washer:	4 mm flat washer
Tightening torque:	550 Nm (screws lubricated with Molykote 1000) 600-725 Nm, typical 650 Nm (screws none or lightly lubricated)



Note

Only two guide pins shall be used. The corresponding holes in the base plate shall be circular according to figure [Base plate drawing on page 27](#).

AbsAcc performance

Regarding AbsAcc performance, the use of guide pins are mandatory.

Continues on next page

Base plate drawing



Note

IRB 6700INV is not valid for base plate.

The following figure shows the option base plate (dimensions in mm).

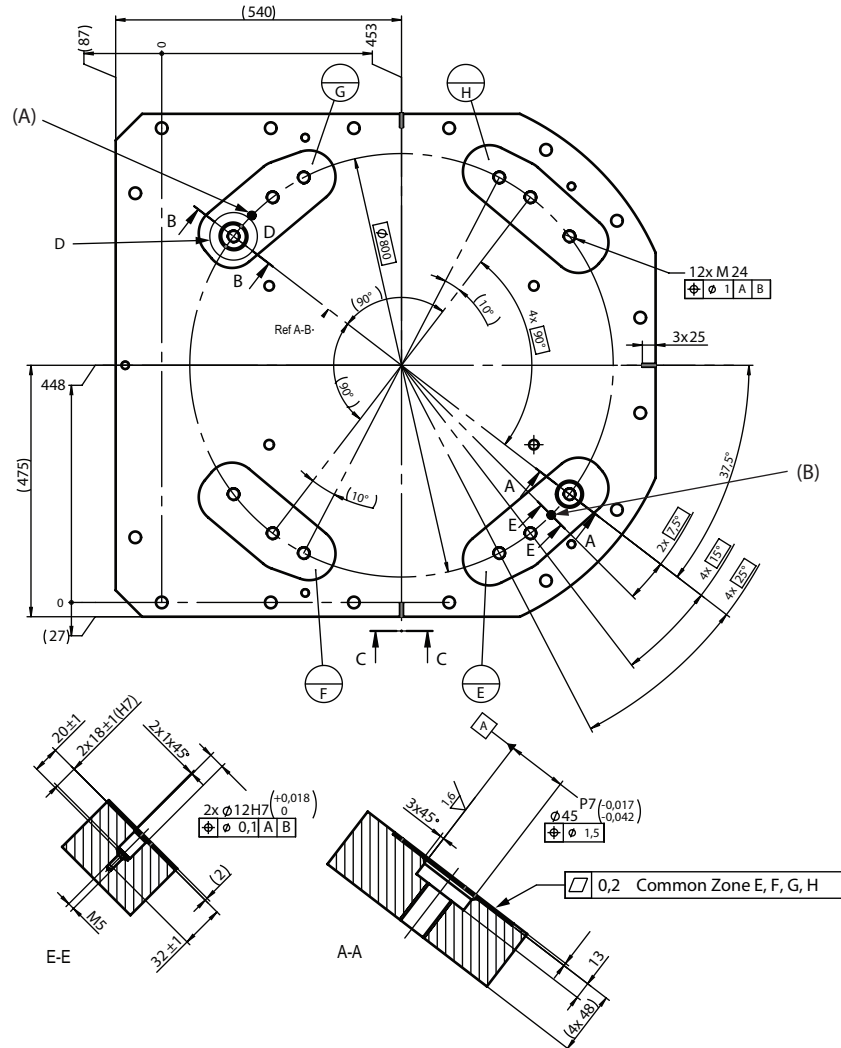

xx150000246

Pos	Description
A, B	Hole for guide pin, cylindrical, see Guide pins on page 30
E, F, G, H	Common tolerance zone (accuracy all over the base plate from one contact surface to the other)

Continues on next page

1 Description

1.3.3 Assembling the manipulator

Continued

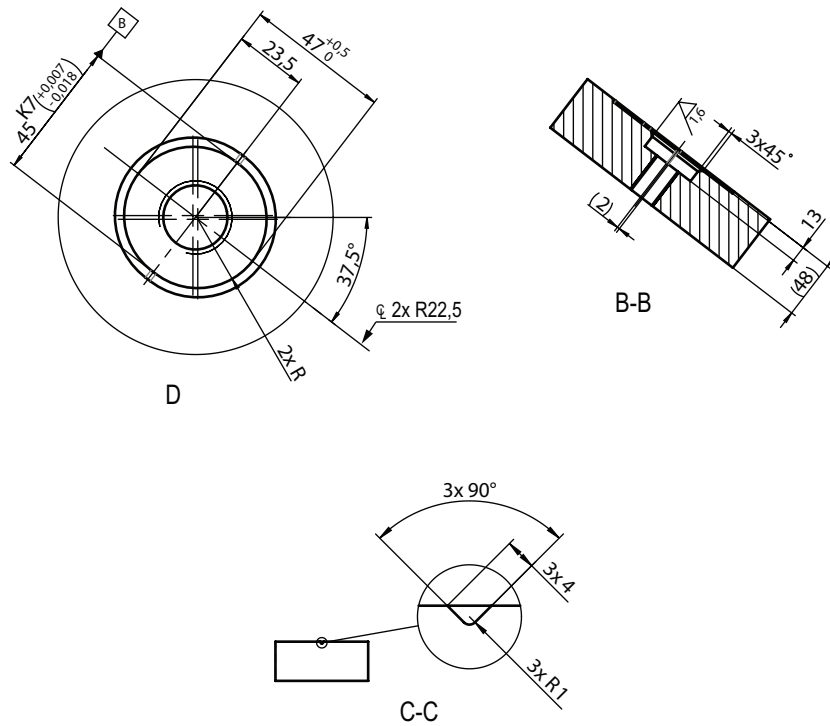

xx150000247

Continues on next page

1 Description

1.3.3 Assembling the manipulator

Continued

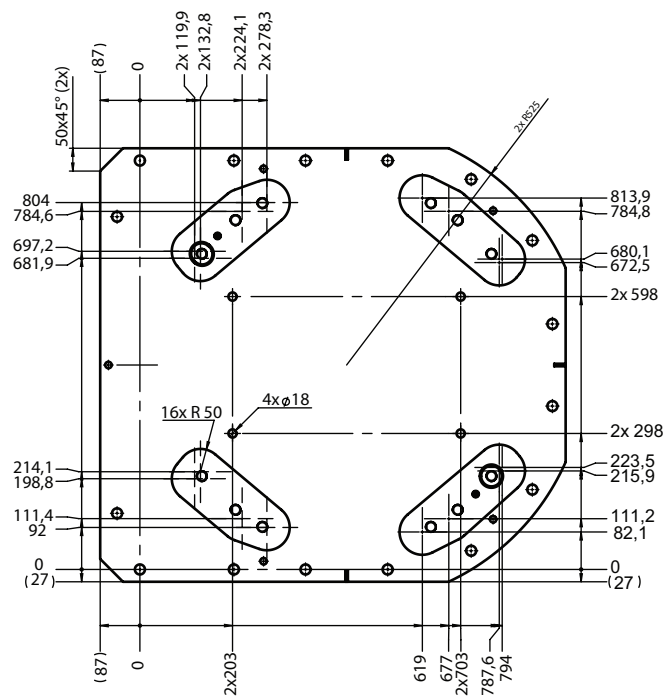
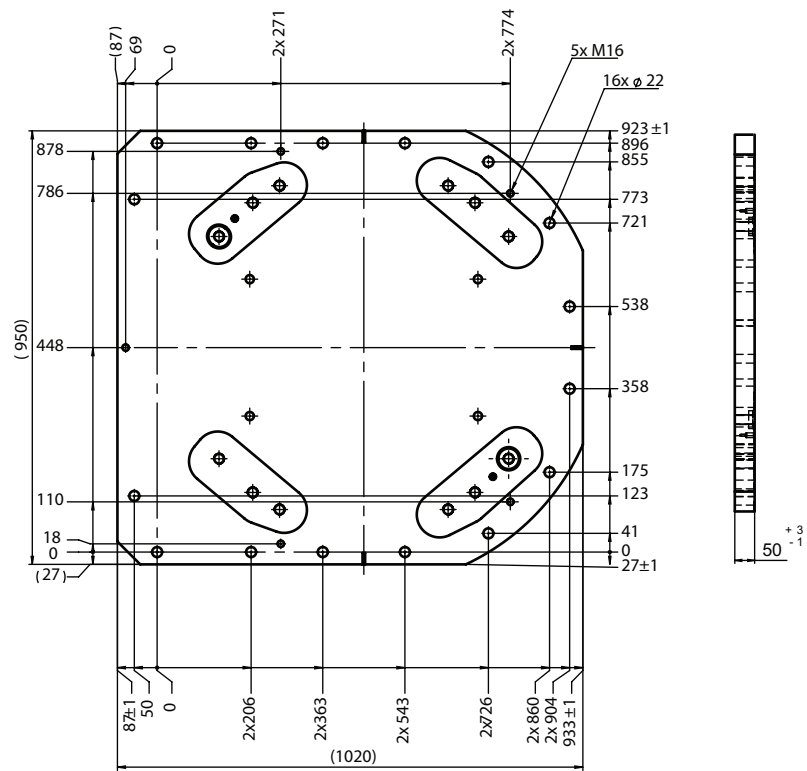

xx1500000249

A	<p>Color: RAL 9005 Thickness: 80-100 μm Weight: 360 kg</p>
---	---

Continues on next page

1 Description

1.3.3 Assembling the manipulator

Continued

Guide pins

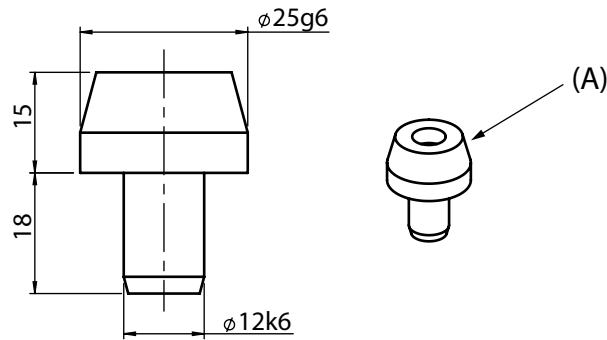

XX1500000248

Pos	Description
A	Cylindrical guide pin (x2)

Assembly of guide pins

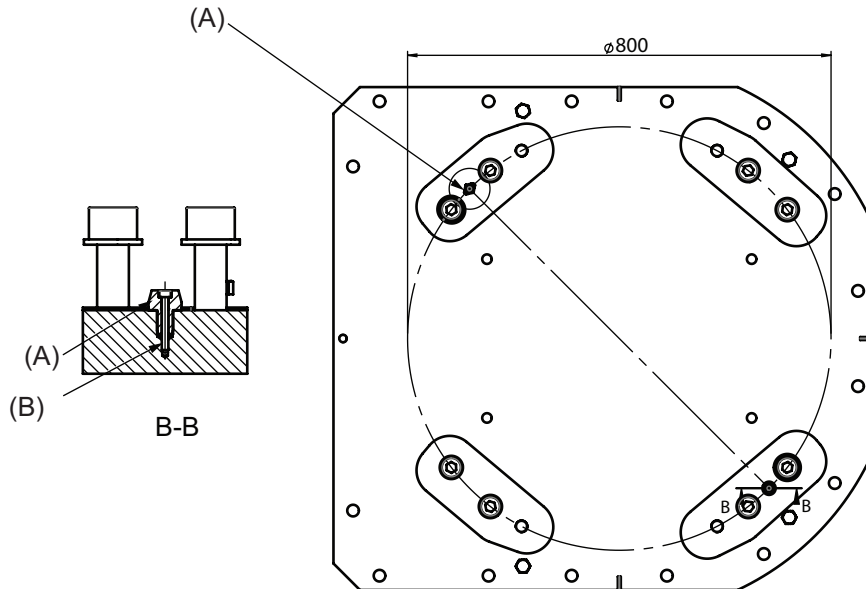

Pos	Description
A	Cylindrical guide pin (x2)
B	M5 x 40. Tightening torque 6 Nm. (x2)



Note

All screws and pins are delivered in a plastic bag together with the base plate.

1.4 Calibration and references

1.4.1 Calibration methods

Overview

This section specifies the different types of calibration and the calibration methods that are supplied by ABB.

The original calibration data delivered with the robot is generated when the robot is floor mounted. If the robot is not floor mounted, then the robot accuracy could be affected. The robot needs to be calibrated after it is mounted.

More information is available in the product manual.

Types of calibration

Type of calibration	Description	Calibration method
Standard calibration	<p>The calibrated robot is positioned at calibration position.</p> <p>Standard calibration data is found on the SMB (serial measurement board) or EIB in the robot.</p> <p>For robots with RobotWare 5.04 or older, the calibration data is delivered in a file, <code>calib.cfg</code>, supplied with the robot at delivery. The file identifies the correct resolver/motor position corresponding to the robot home position.</p>	Axis Calibration
Absolute accuracy calibration (optional)	<p>Based on standard calibration, and besides positioning the robot at synchronization position, the Absolute accuracy calibration also compensates for:</p> <ul style="list-style-type: none"> • Mechanical tolerances in the robot structure • Deflection due to load <p>Absolute accuracy calibration focuses on positioning accuracy in the Cartesian coordinate system for the robot.</p> <p>Absolute accuracy calibration data is found on the SMB (serial measurement board) in the robot.</p> <p>For robots with RobotWare 5.05 or older, the absolute accuracy calibration data is delivered in a file, <code>absacc.cfg</code>, supplied with the robot at delivery. The file replaces the <code>calib.cfg</code> file and identifies motor positions as well as absolute accuracy compensation parameters.</p> <p>A robot calibrated with Absolute accuracy has a sticker next to the identification plate of the robot.</p> <p>To regain 100% Absolute accuracy performance, the robot must be recalibrated for absolute accuracy after repair or maintenance that affects the mechanical structure.</p> <div style="border: 1px solid black; padding: 5px; margin-top: 10px;">  <p style="text-align: center; margin: 0;">ABSOLUTE ACCURACY</p> <p style="text-align: right; font-size: small; margin: 0;">3HAC 14257-1</p> </div> <p style="font-size: x-small; margin-top: 5px;">xx0400001197</p>	CalibWare

Continues on next page

1 Description

1.4.1 Calibration methods

Continued

Brief description of calibration methods

Axis Calibration method

Axis Calibration is a standard calibration method for calibration of IRB 6700 and is the most accurate method for the standard calibration. It is the recommended method in order to achieve proper performance.

The following routines are available for the Axis Calibration method:

- Fine calibration
- Update revolution counters
- Reference calibration

The calibration equipment for Axis Calibration is delivered as a toolkit.

The actual instructions of how to perform the calibration procedure and what to do at each step is given on the FlexPendant. You will be guided through the calibration procedure, step by step.

CalibWare - Absolute Accuracy calibration

The CalibWare tool guides through the calibration process and calculates new compensation parameters. This is further detailed in the *Application manual - CalibWare Field*.

If a service operation is done to a robot with the option Absolute Accuracy, a new absolute accuracy calibration is required in order to establish full performance. For most cases after replacements that do not include taking apart the robot structure, standard calibration is sufficient.

1.4.2 Fine calibration

General

Fine calibration is made using the Calibration Pendulum, see *Operating manual - Calibration Pendulum* or Axis calibration, see *Product manual - IRB 6700* and *Product manual - IRB 6700Inv*.

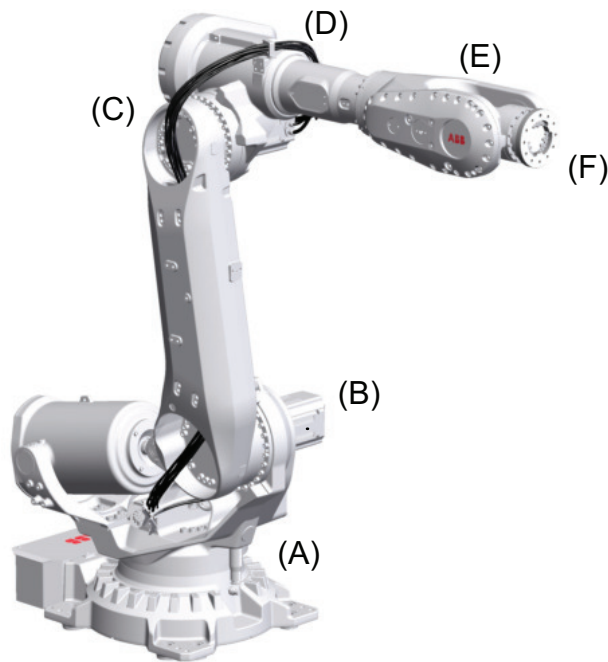

xx130000244

Axes

Pos	Description	Pos	Description
A	Axis 1	B	Axis 2
C	Axis 3	D	Axis 4
E	Axis 5	F	Axis 6

Calibration

Calibration	Position
Calibration of all axes	All axes are in zero position
Calibration of axis 1 and 2	Axis 1 and 2 in zero position
	Axis 3 to 6 in any position
Calibration of axis 1	Axis 1 in zero position
	Axis 2 to 6 in any position

1 Description

1.4.3 Absolute Accuracy calibration

1.4.3 Absolute Accuracy calibration



Note

IRB 6700Inv is valid for field AbsAcc but does not have an AbsAcc option.

Purpose

Absolute Accuracy is a calibration concept that improves TCP accuracy. The difference between an ideal robot and a real robot can be several millimeters, resulting from mechanical tolerances and deflection in the robot structure. *Absolute Accuracy* compensates for these differences.

Here are some examples of when this accuracy is important:

- Exchangeability of robots
- Offline programming with no or minimum touch-up
- Online programming with accurate movement and reorientation of tool
- Programming with accurate offset movement in relation to eg. vision system or offset programming
- Re-use of programs between applications

The option *Absolute Accuracy* is integrated in the controller algorithms and does not need external equipment or calculation.



Note

The performance data is applicable to the corresponding RobotWare version of the individual robot.

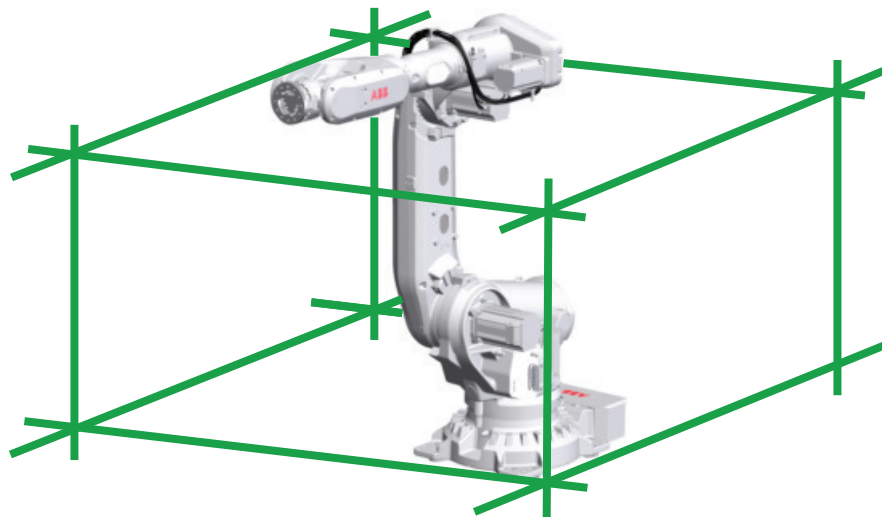

xx1300002177

What is included

Every *Absolute Accuracy* robot is delivered with:

- compensation parameters saved on the robot's serial measurement board

Continues on next page

- a birth certificate representing the *Absolute Accuracy* measurement protocol for the calibration and verification sequence.

A robot with *Absolute Accuracy* calibration has a label with this information on the manipulator.

Absolute Accuracy supports floor mounted, wall mounted and ceiling mounted installations. Compensation parameters saved in the robot's serial measurement board differ depending on which Absolute Accuracy option is selected.

When is *Absolute Accuracy* being used

Absolute Accuracy works on a robot target in Cartesian coordinates, not on the individual joints. Therefore, joint based movements (e.g. `MoveAbsJ`) will not be affected.

If the robot is inverted, the Absolute Accuracy calibration must be performed when the robot is inverted.

Absolute Accuracy active

Absolute Accuracy will be active in the following cases:

- Any motion function based on robtargets (e.g. `MoveL`) and ModPos on robtargets
- Reorientation jogging
- Linear jogging
- Tool definition (4, 5, 6 point tool definition, room fixed TCP, stationary tool)
- Work object definition

Absolute Accuracy not active

The following are examples of when Absolute Accuracy is not active:

- Any motion function based on a jointtarget (`MoveAbsJ`)
- Independent joint
- Joint based jogging
- Additional axes
- Track motion



Note

In a robot system with, for example, an additional axis or track motion, the Absolute Accuracy is active for the manipulator but not for the additional axis or track motion.

RAPID instructions

There are no RAPID instructions included in this option.

Continues on next page

1 Description

1.4.3 Absolute Accuracy calibration

Continued

Production data

Typical production data regarding calibration are:

Robot	Positioning accuracy (mm)		
	Average	Max	% Within 1 mm
IRB 6700 (all variants except LeanID)	0.35	0.75	100
IRB 6700 LeanID (all variants)	0.40	0.85	100

1.5 Load diagrams

1.5.1 Introduction

**WARNING**

It is very important to always define correct actual load data and correct payload of the robot. Incorrect definitions of load data can result in overloading of the robot.

If incorrect load data is used, and/or if loads outside the load diagram are used, the following parts can be damaged due to overload:

- motors
- gearboxes
- mechanical structure

**WARNING**

In RobotWare, the service routine LoadIdentify can be used to determine correct load parameters. The routine automatically defines the tool and the load. See *Operating manual - IRC5 with FlexPendant*, for detailed information.

**WARNING**

Robots running with incorrect load data and/or with loads outside the load diagram, will not be covered by robot warranty.

General

The load diagrams include a nominal payload inertia, J_0 of 15 kgm^2 , and an extra load of 50 kg at the upper arm housing.

At different moment of inertia the load diagram will be changed. For robots that are allowed tilted, wall or inverted mounted, the load diagrams as given are valid and thus it is also possible to use RobotLoad within those tilt and axis limits.

Control of load case by "RobotLoad"

To verify a specific load case, use the RobotStudio add-in RobotLoad.

The result from RobotLoad is only valid within the maximum loads and tilt angles. There is no warning if the maximum permitted arm load is exceeded. For over-load cases and special applications, contact ABB for further analysis.

1 Description

1.5.2 Diagrams

1.5.2 Diagrams

IRB 6700-235/2.65

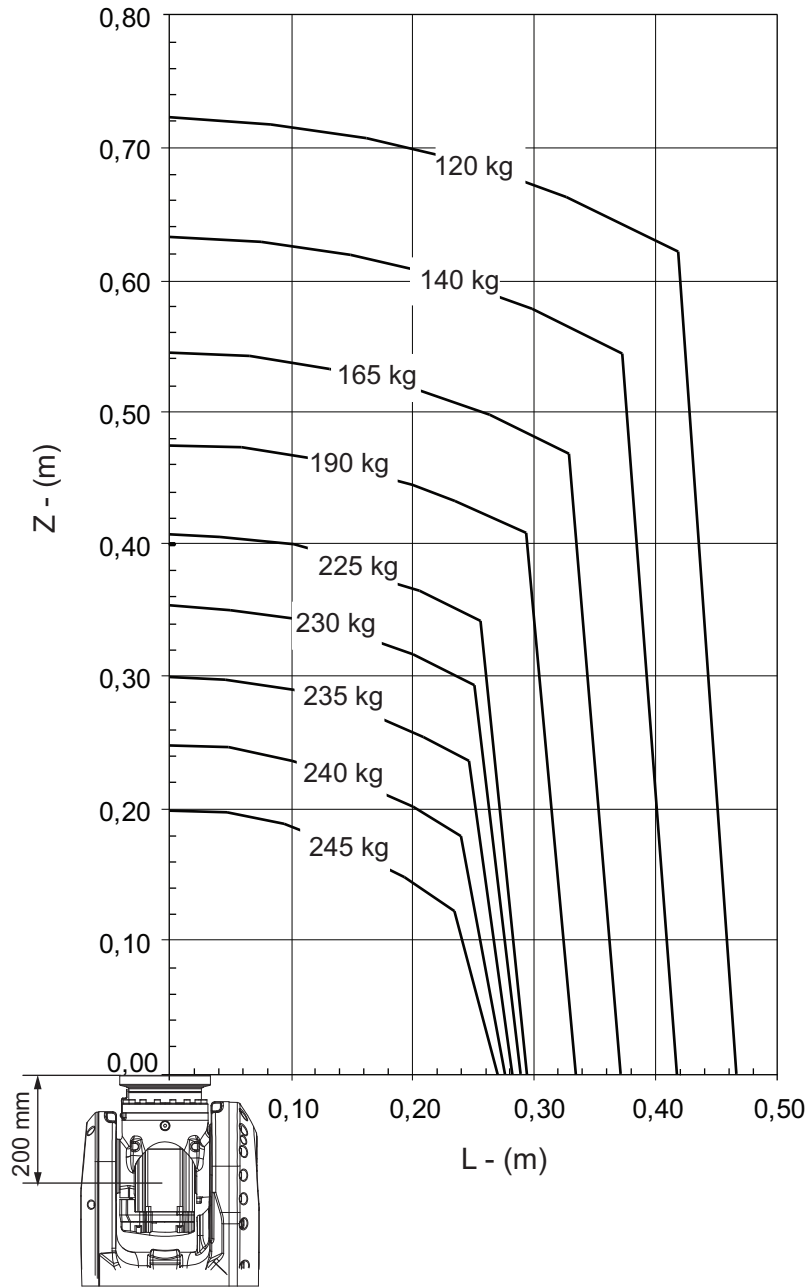

xx1300000245

Continues on next page

IRB 6700-235/2.65 "Vertical Wrist" ($\pm 10^\circ$)

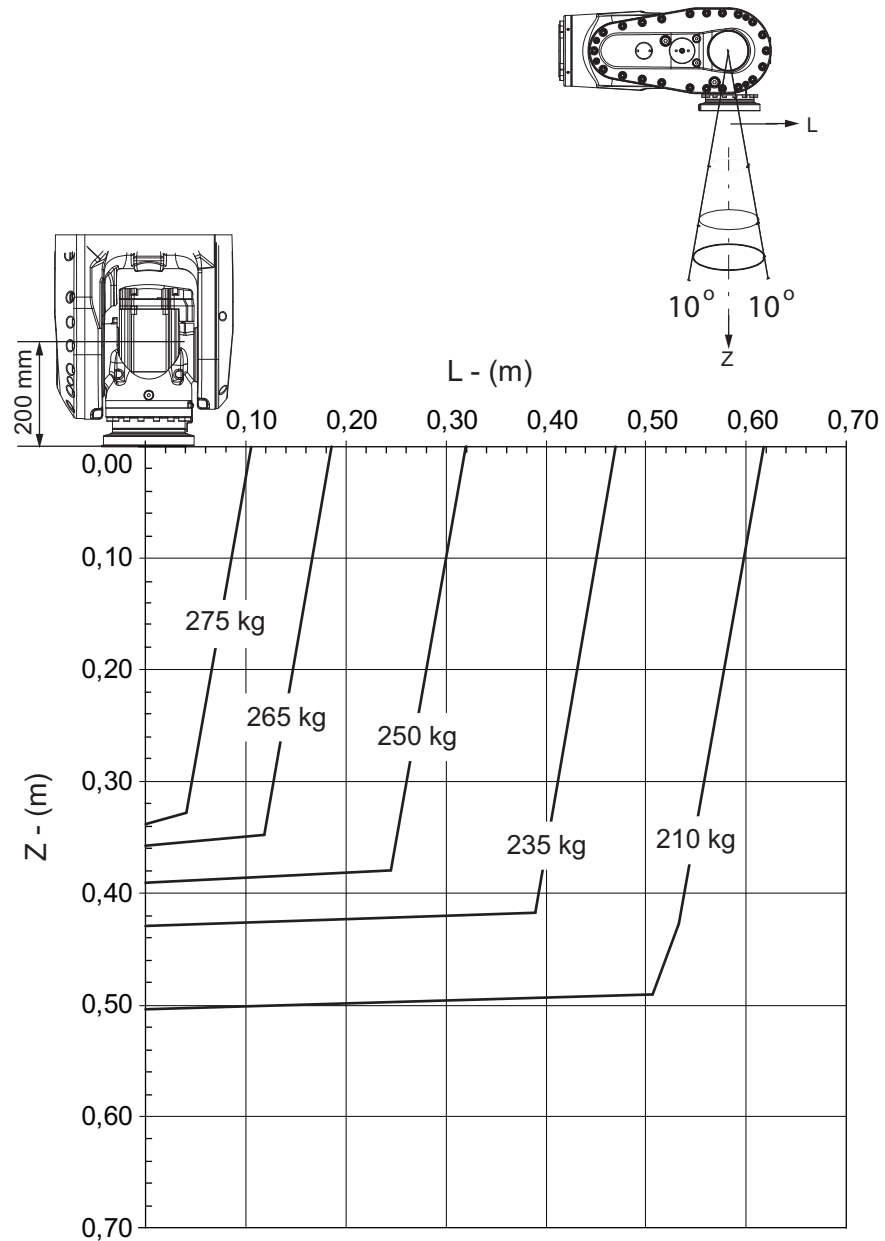

xx1300000246

For wrist down (0° deviation from the vertical line).

	Description
Max load	280 kg
Z _{max}	0.327 m
L _{max}	0.100 m

Continues on next page

1 Description

1.5.2 Diagrams

Continued

IRB 6700-235/2.65 "LeanID", option 780-4

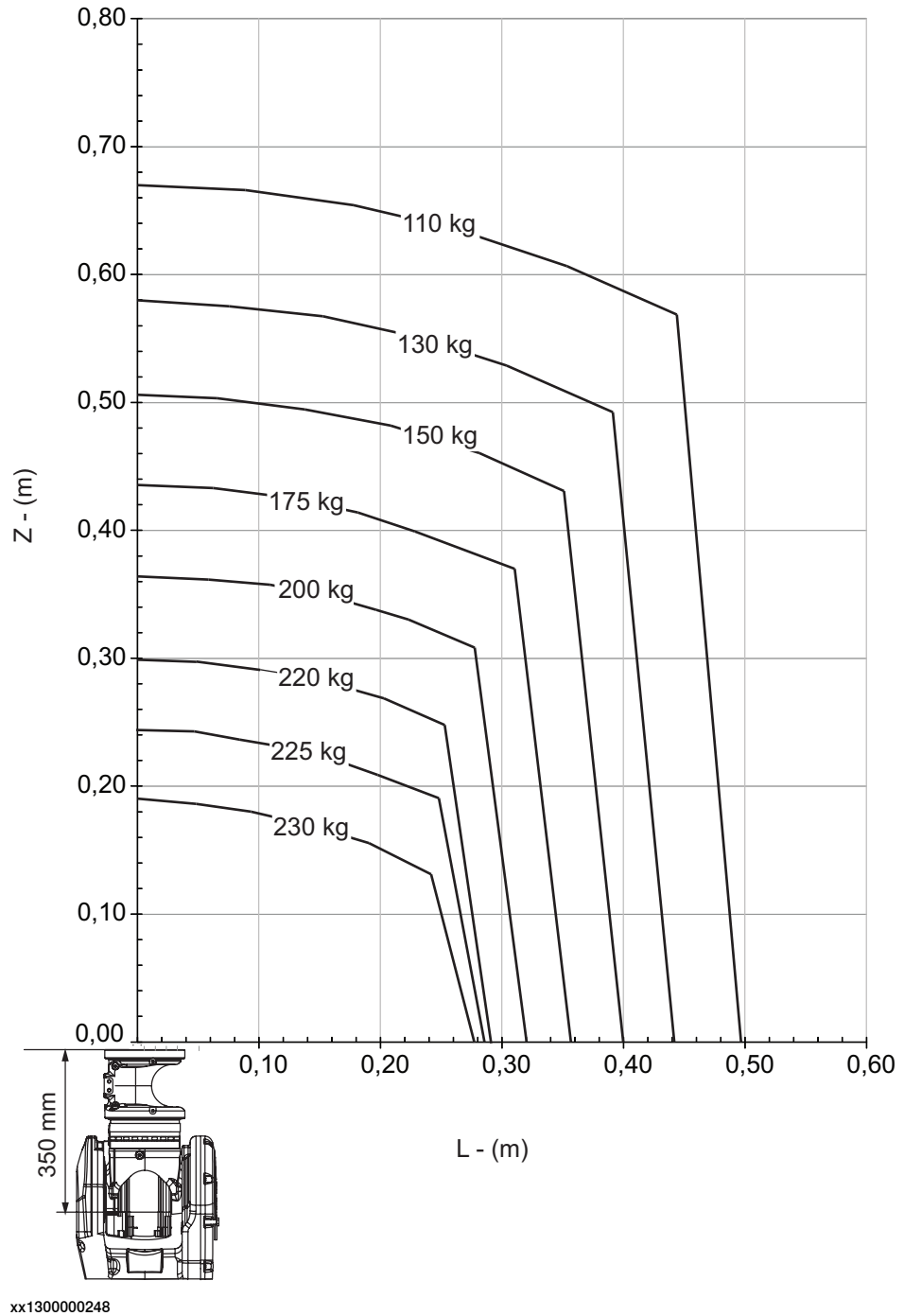

Continues on next page

IRB 6700-205/2.80

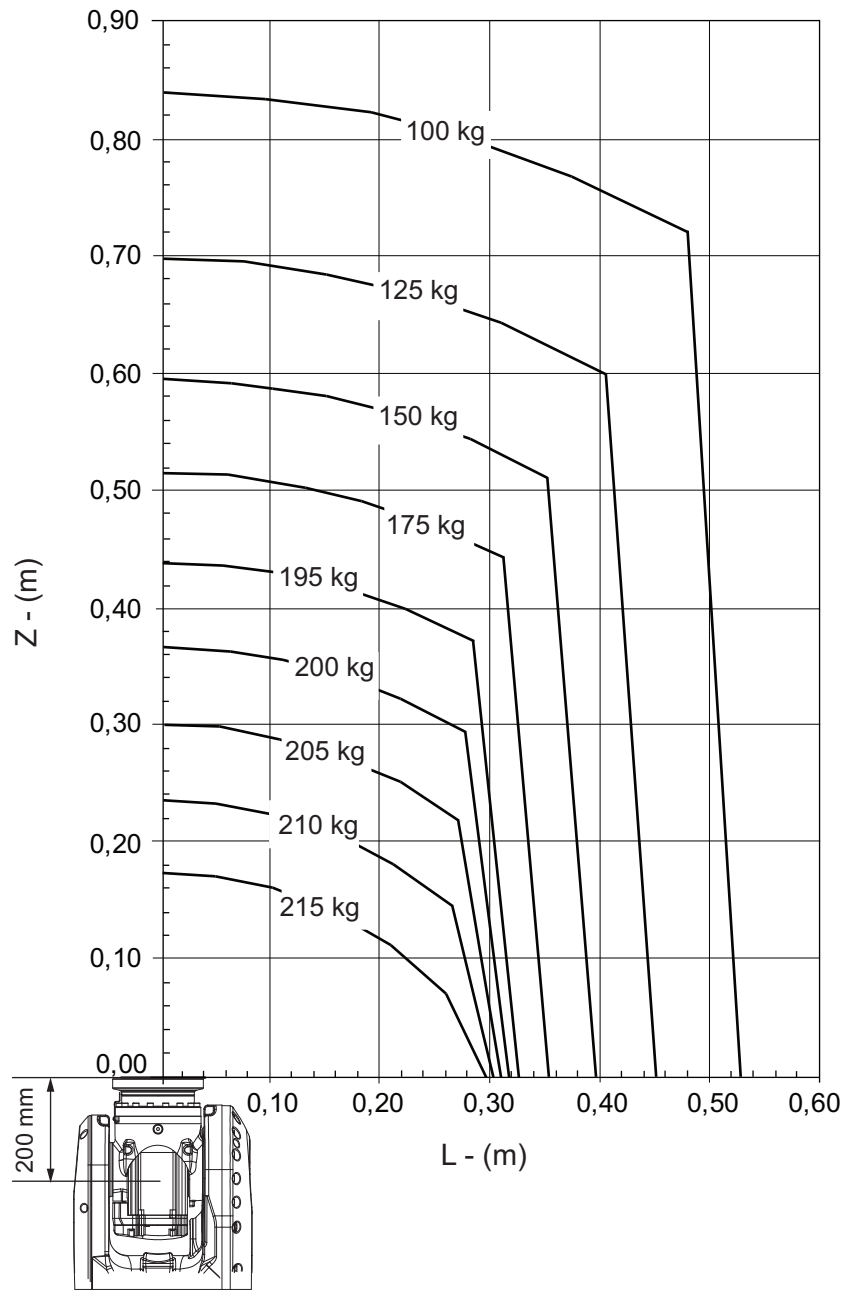

xx130000249

Continues on next page

1 Description

1.5.2 Diagrams

Continued

IRB 6700-205/2.80 "Vertical Wrist" ($\pm 10^\circ$)

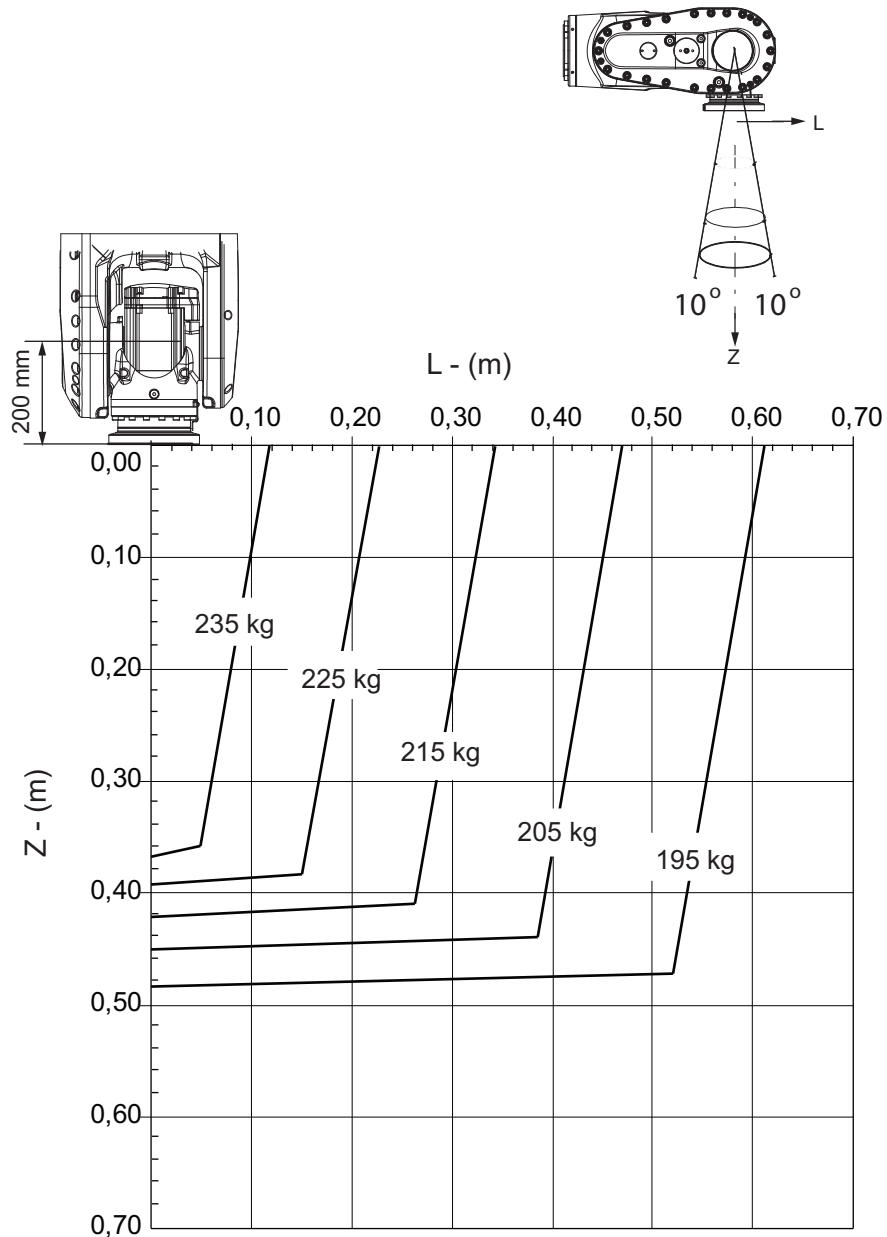

xx1300000250

For wrist down (0° deviation from the vertical line).

	Description
Max load	240 kg
Z _{max}	0.355 m
L _{max}	0.103 m

Continues on next page

IRB 6700-205/2.80 "LeanID", option 780-4

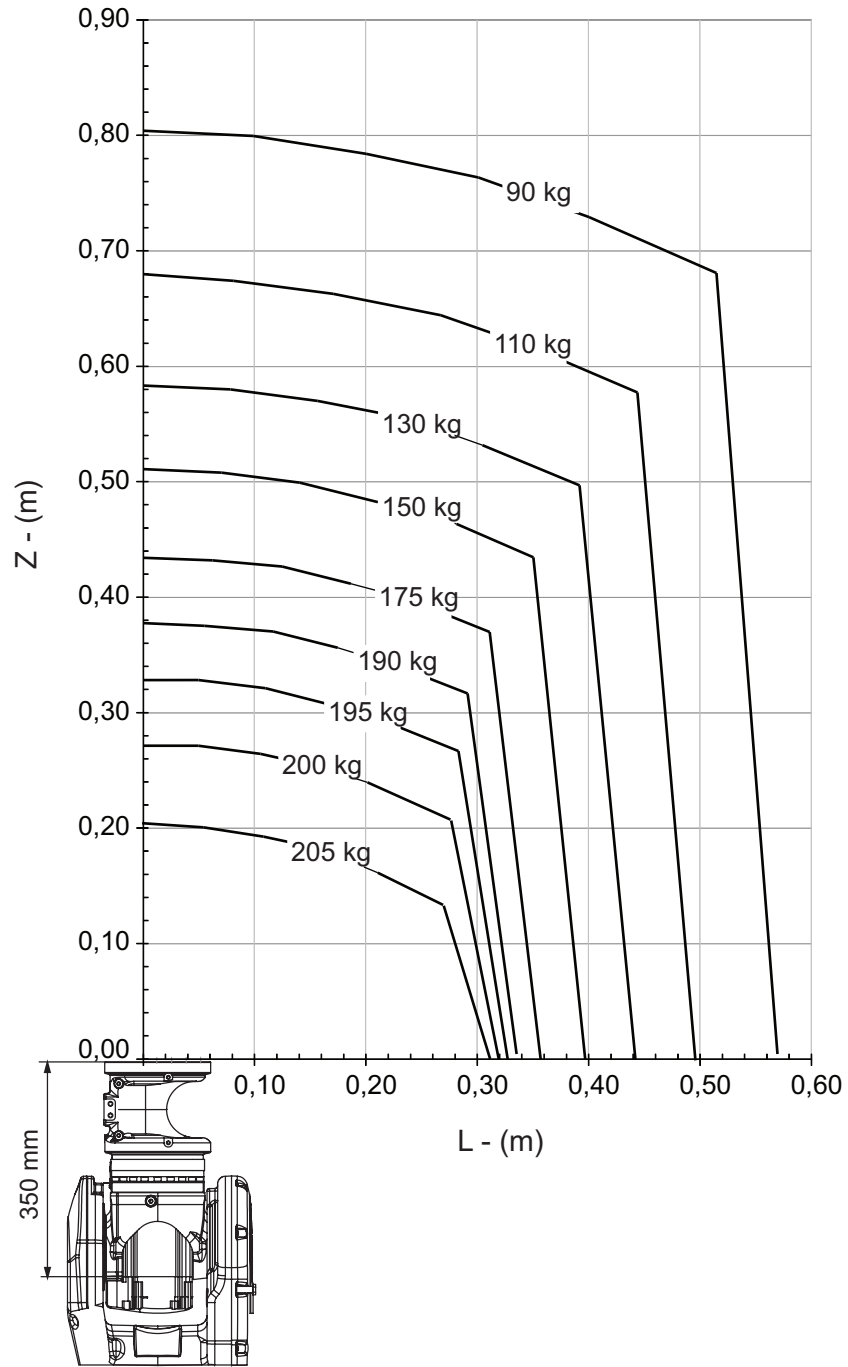

xx1300000251

Continues on next page

1 Description

1.5.2 Diagrams

Continued

IRB 6700-200/2.60

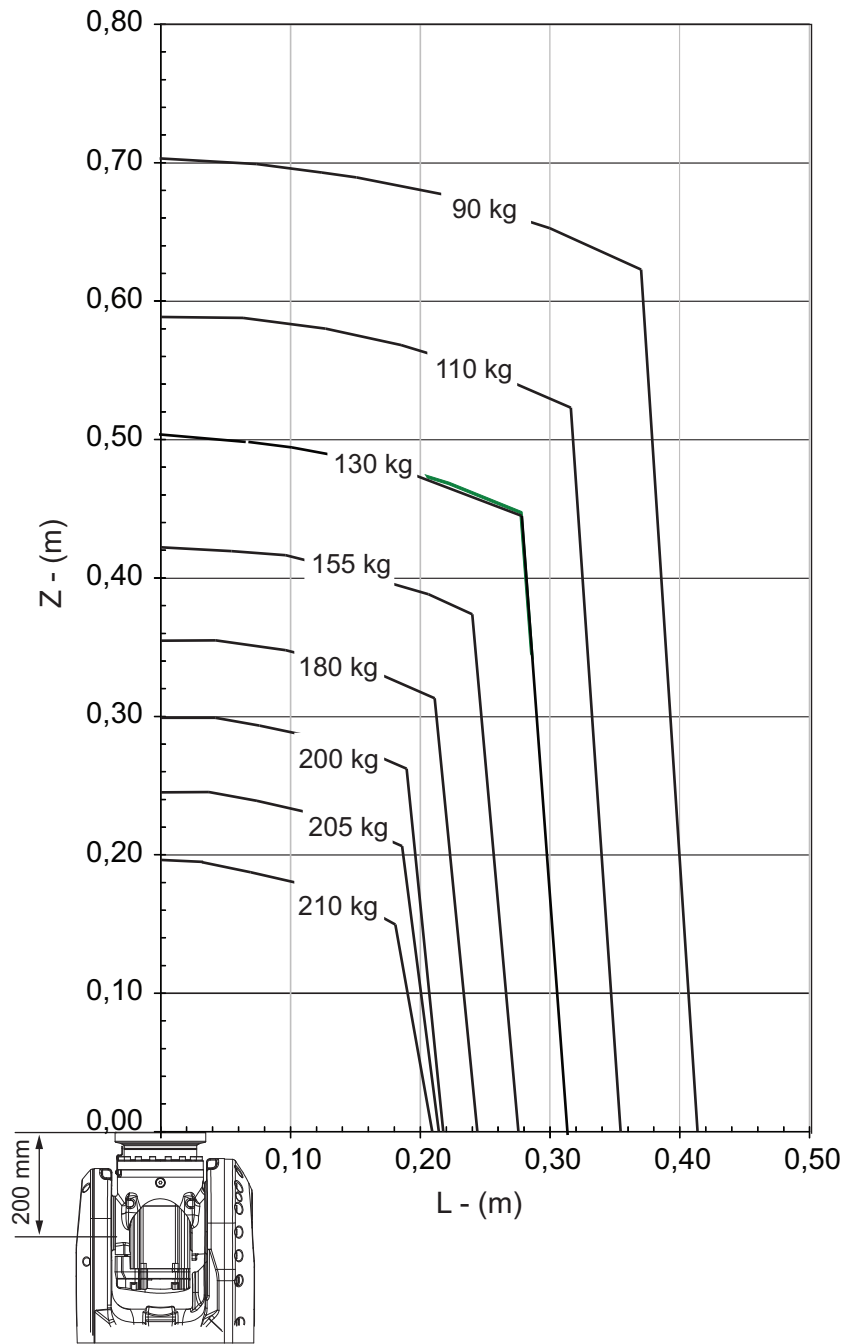

xx1300000333

Continues on next page

IRB 6700-200/2.60 "Vertical Wrist" ($\pm 10^\circ$)

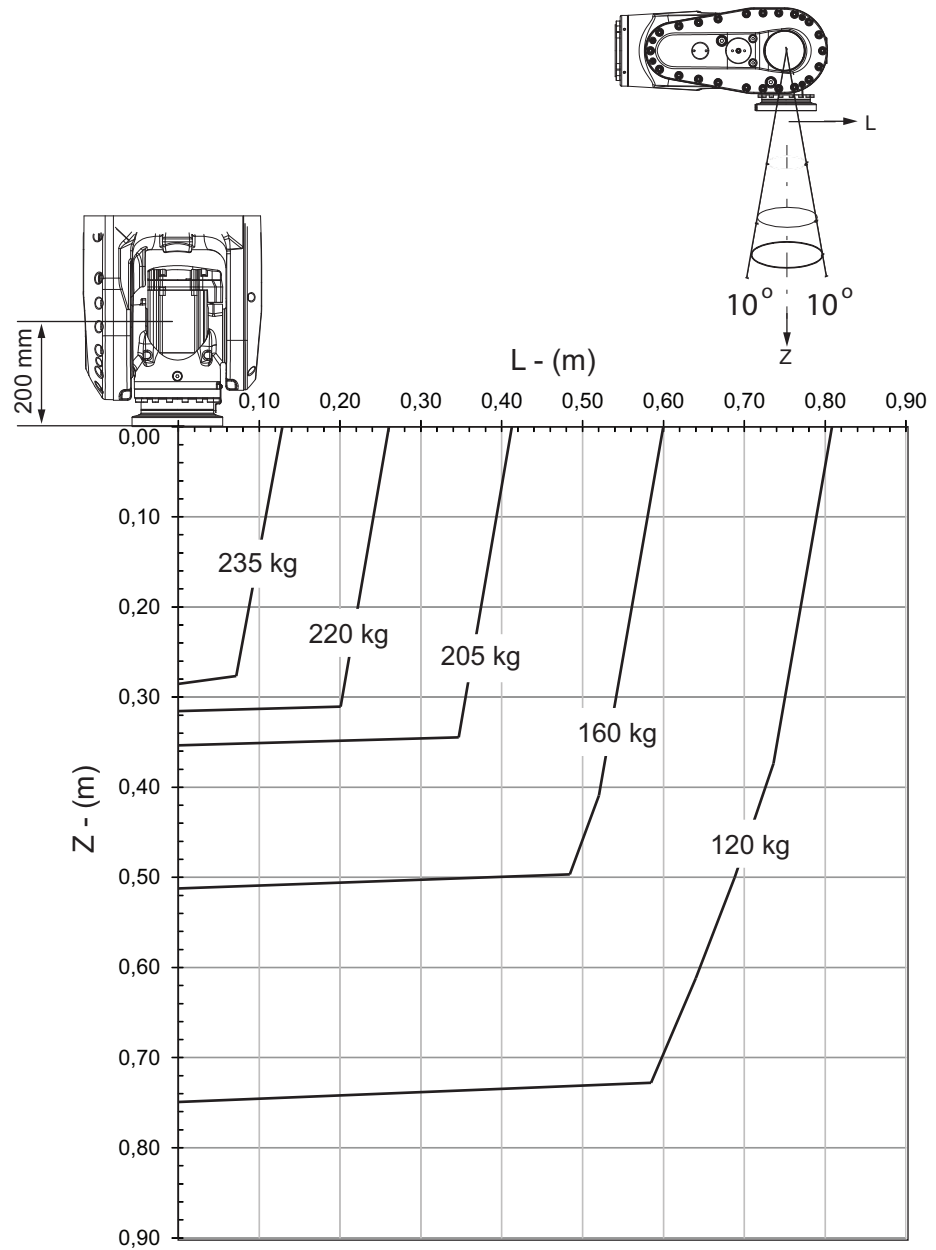

xx130000334

For wrist down (0° deviation from the vertical line).

	Description
Max load	242 kg
Z _{max}	0.27 m
L _{max}	0.104 m

Continues on next page

1 Description

1.5.2 Diagrams

Continued

IRB 6700-200/2.60 "LeanID", option 780-4

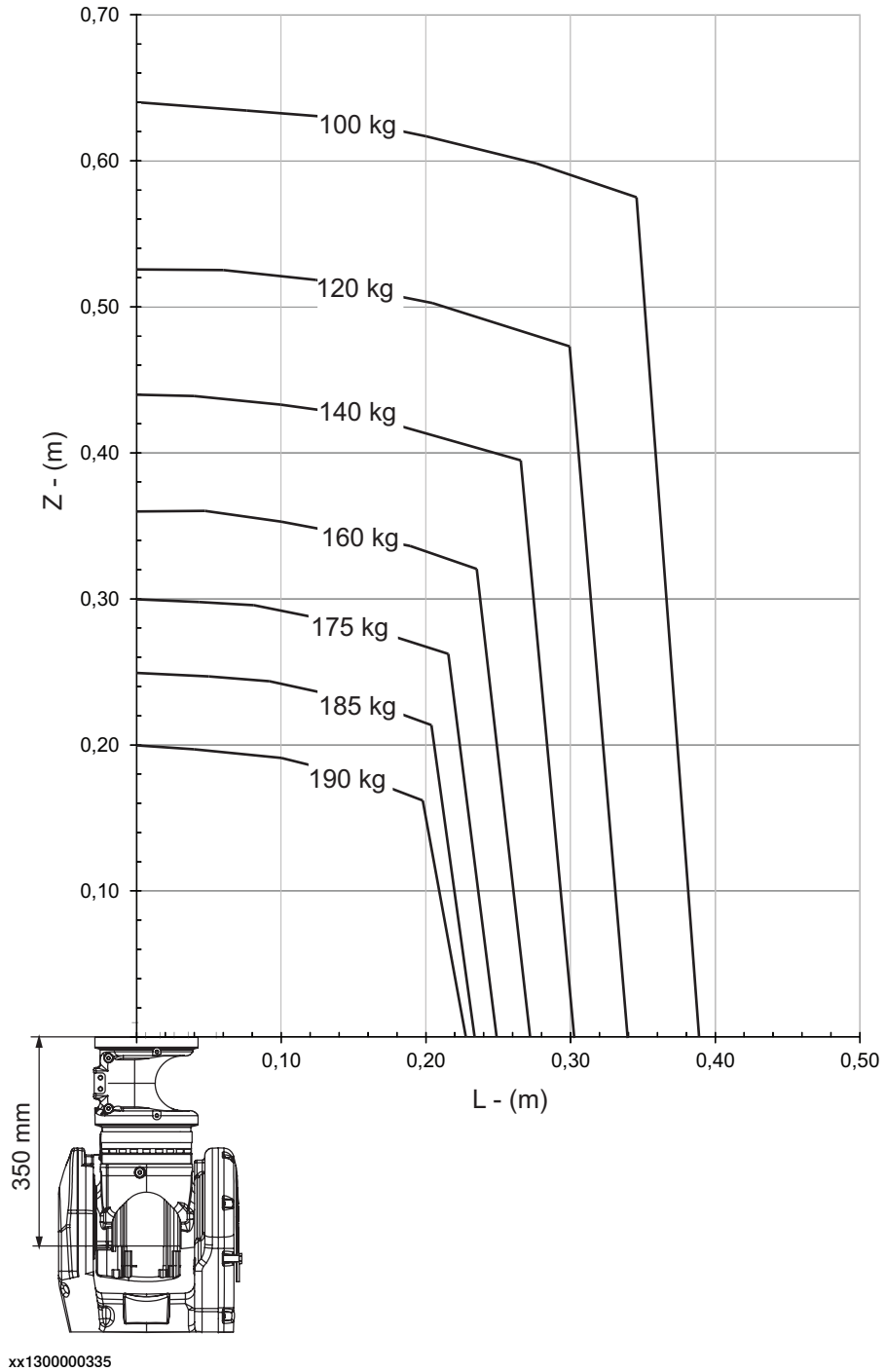

Continues on next page

IRB 6700-175/3.05

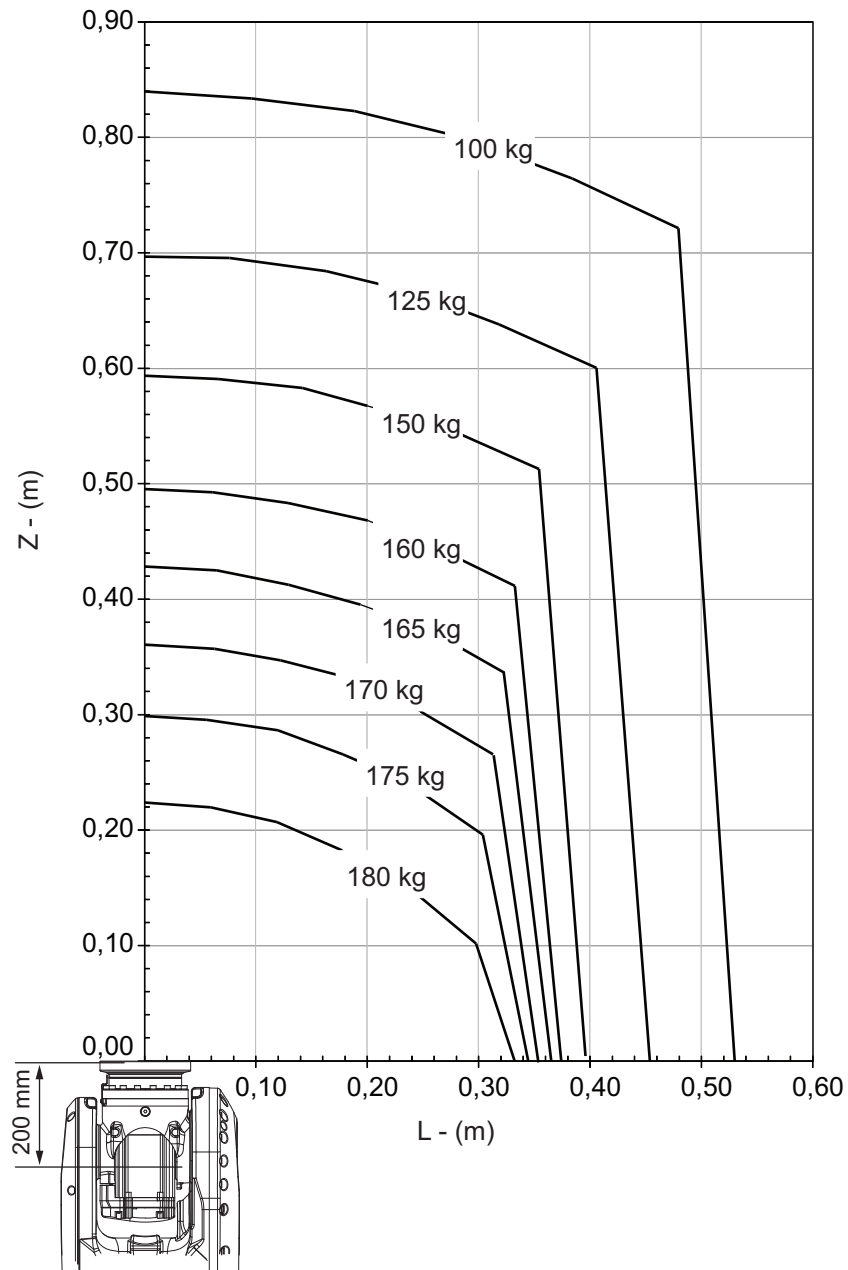

xx1300000252

Continues on next page

1 Description

1.5.2 Diagrams

Continued

IRB 6700-175/3.05 "Vertical Wrist" ($\pm 10^\circ$)

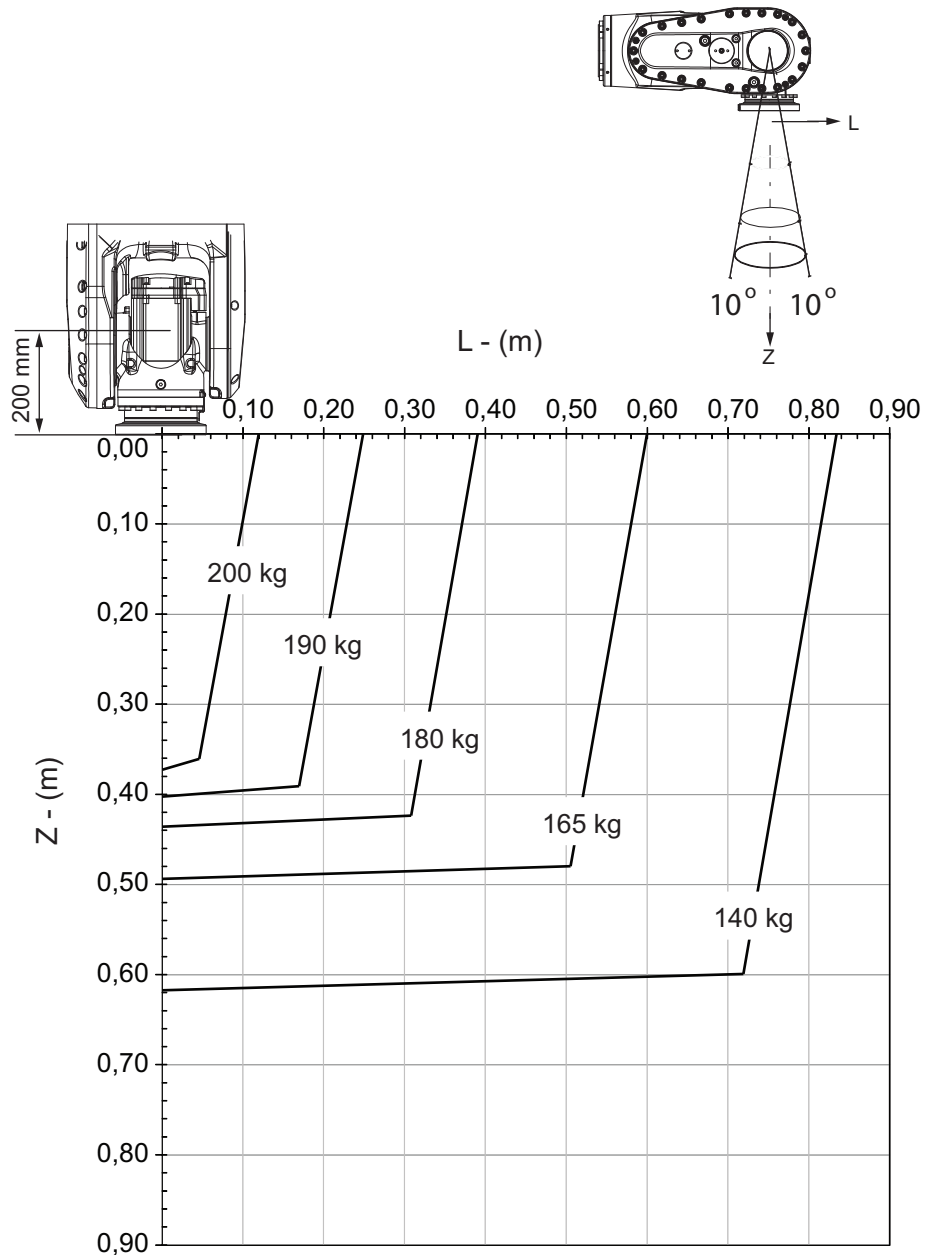

xx1300000253

	Description
Max load	204 kg
Z _{max}	0.360 m
L _{max}	0.101 m

Continues on next page

IRB 6700-175/3.05 "LeanID", option 780-4

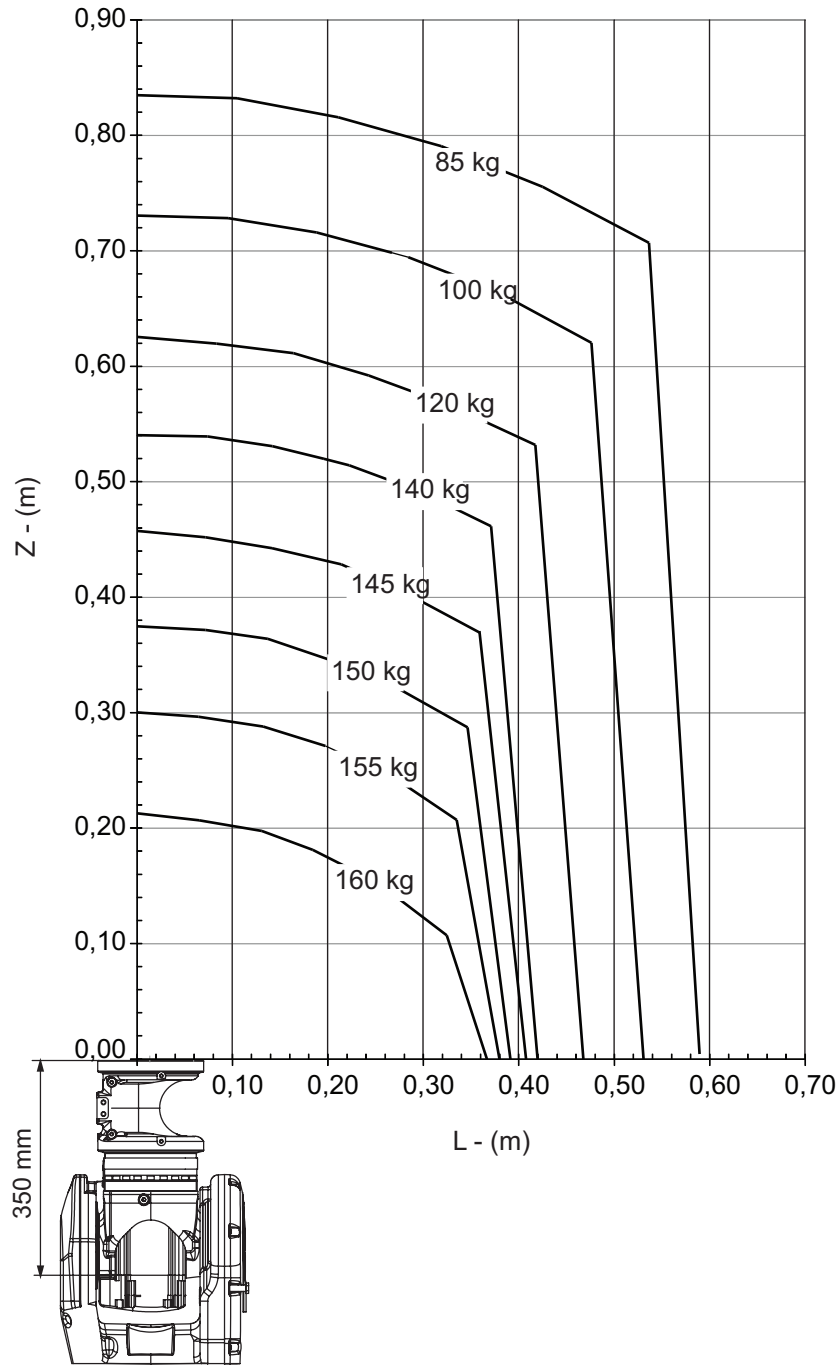

xx130000254

Continues on next page

1 Description

1.5.2 Diagrams

Continued

IRB 6700-155/2.85

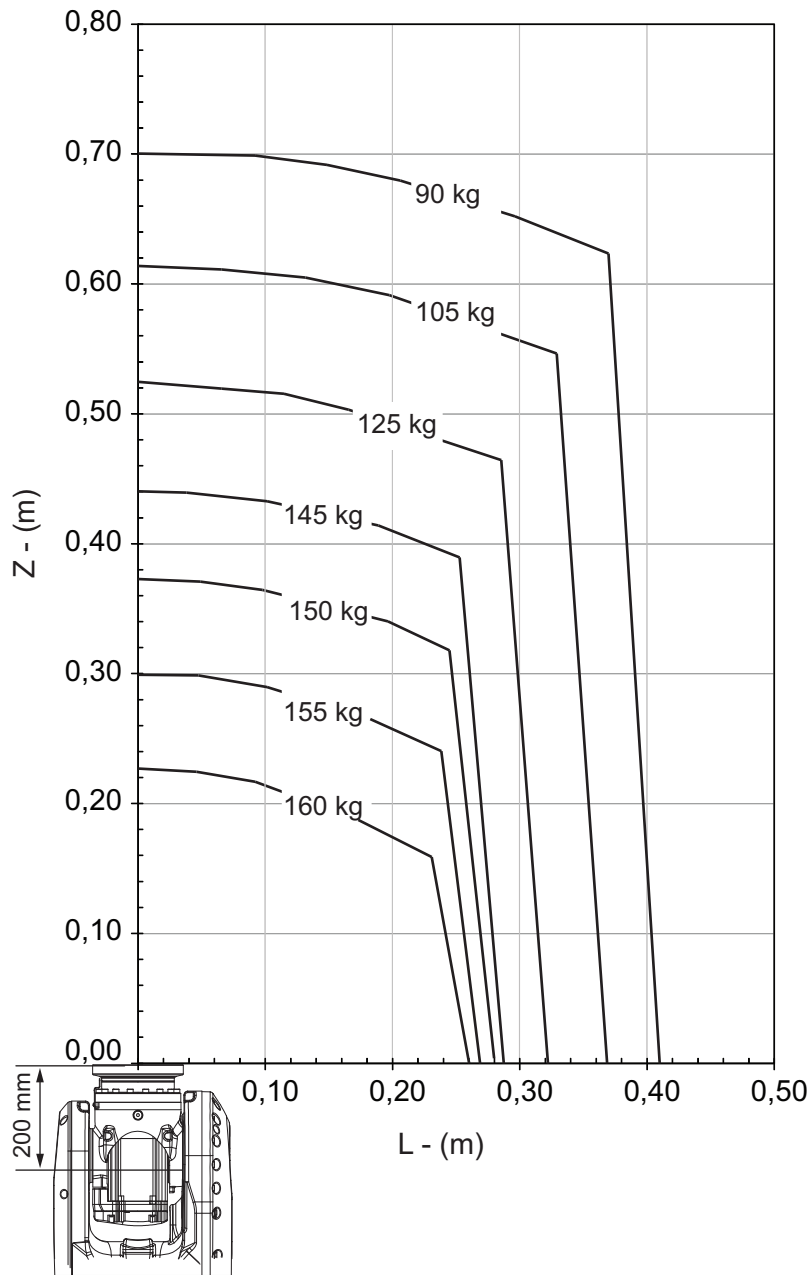

xx1300000336

Continues on next page

IRB 6700-155/2.85 "Vertical Wrist" ($\pm 10^\circ$)

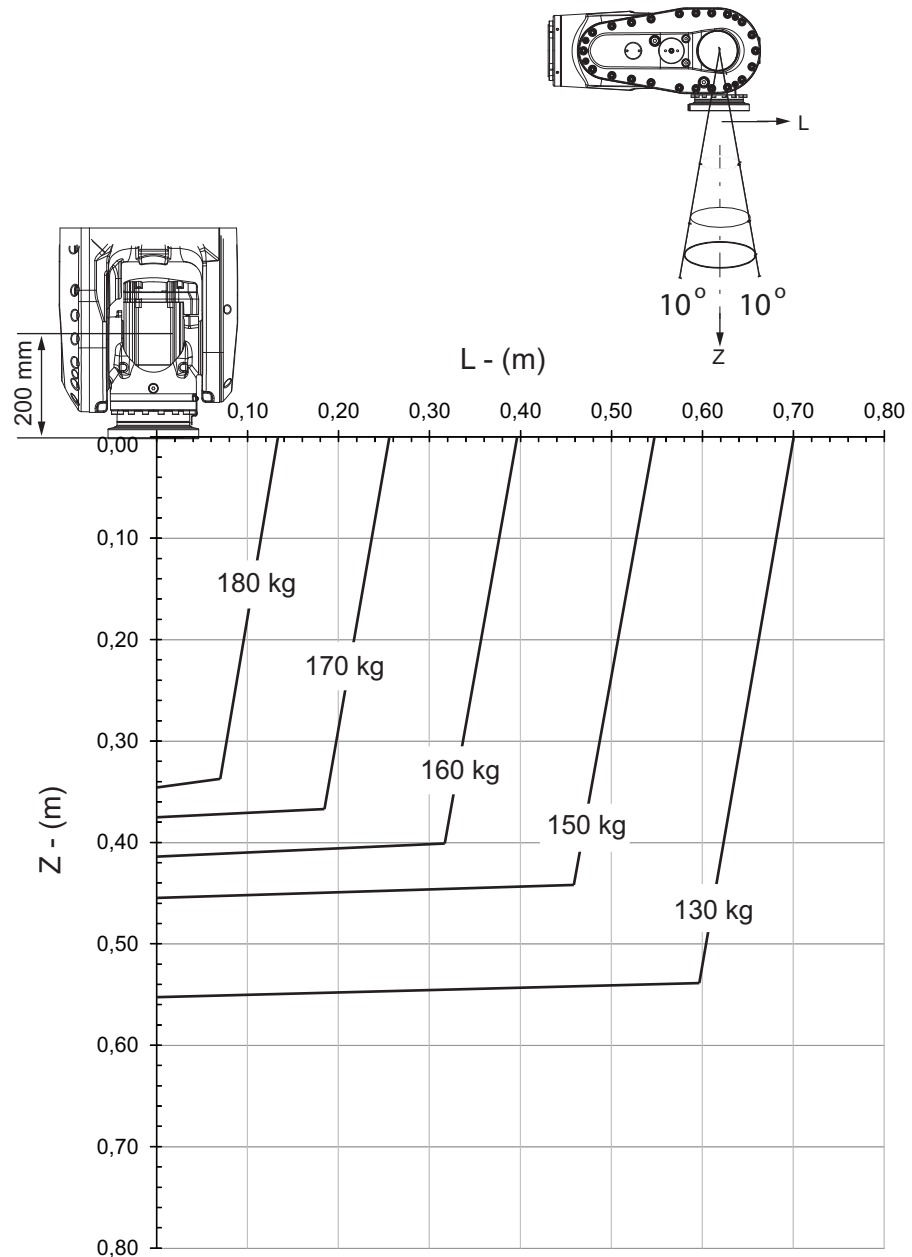

xx1300000337

	Description
Max load	186 kg
Z _{max}	0.327 m
L _{max}	0.101 m

Continues on next page

1 Description

1.5.2 Diagrams

Continued

IRB 6700-155/2.85 "LeanID", option 780-4

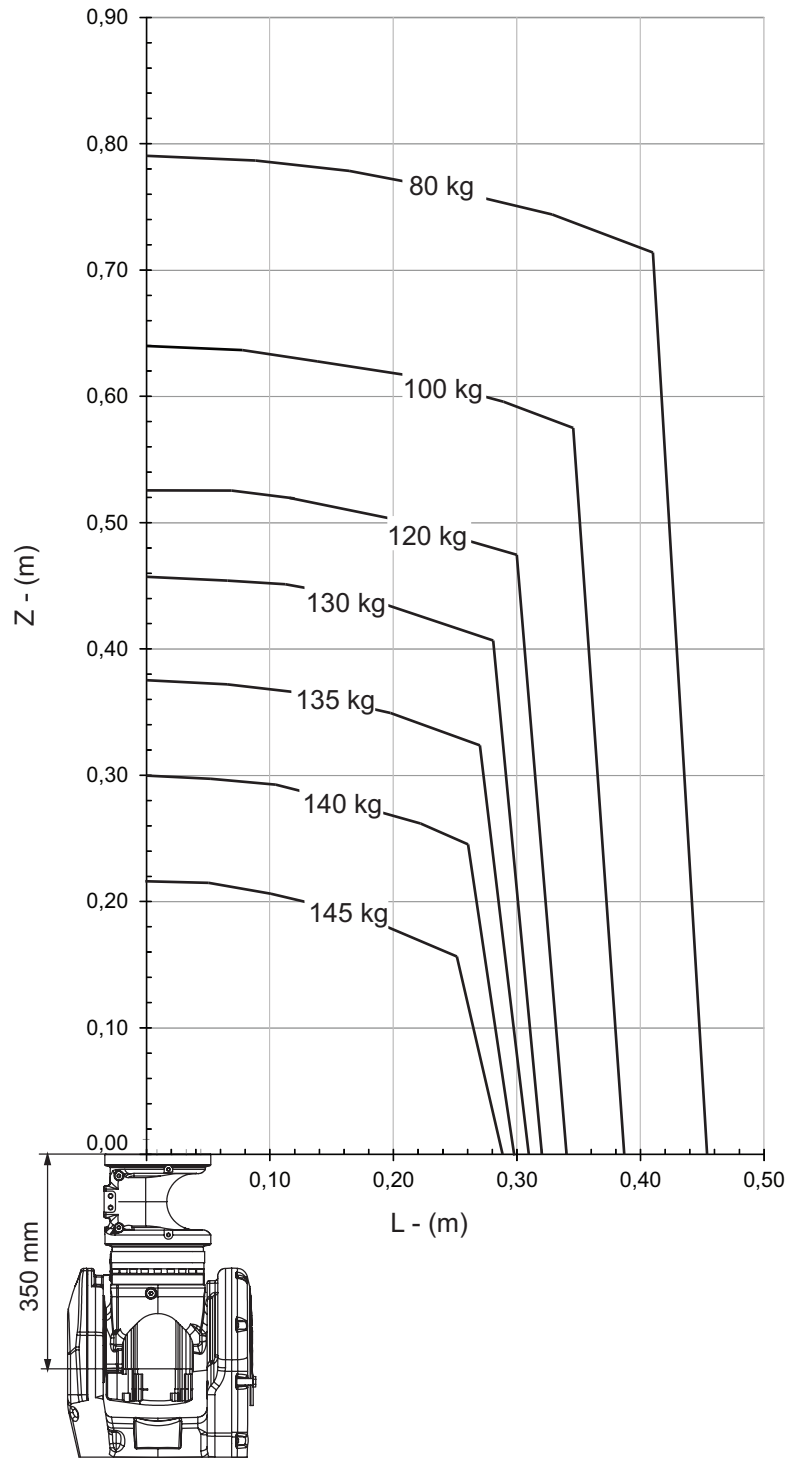

xx1300000338

Continues on next page

IRB 6700-150/3.20

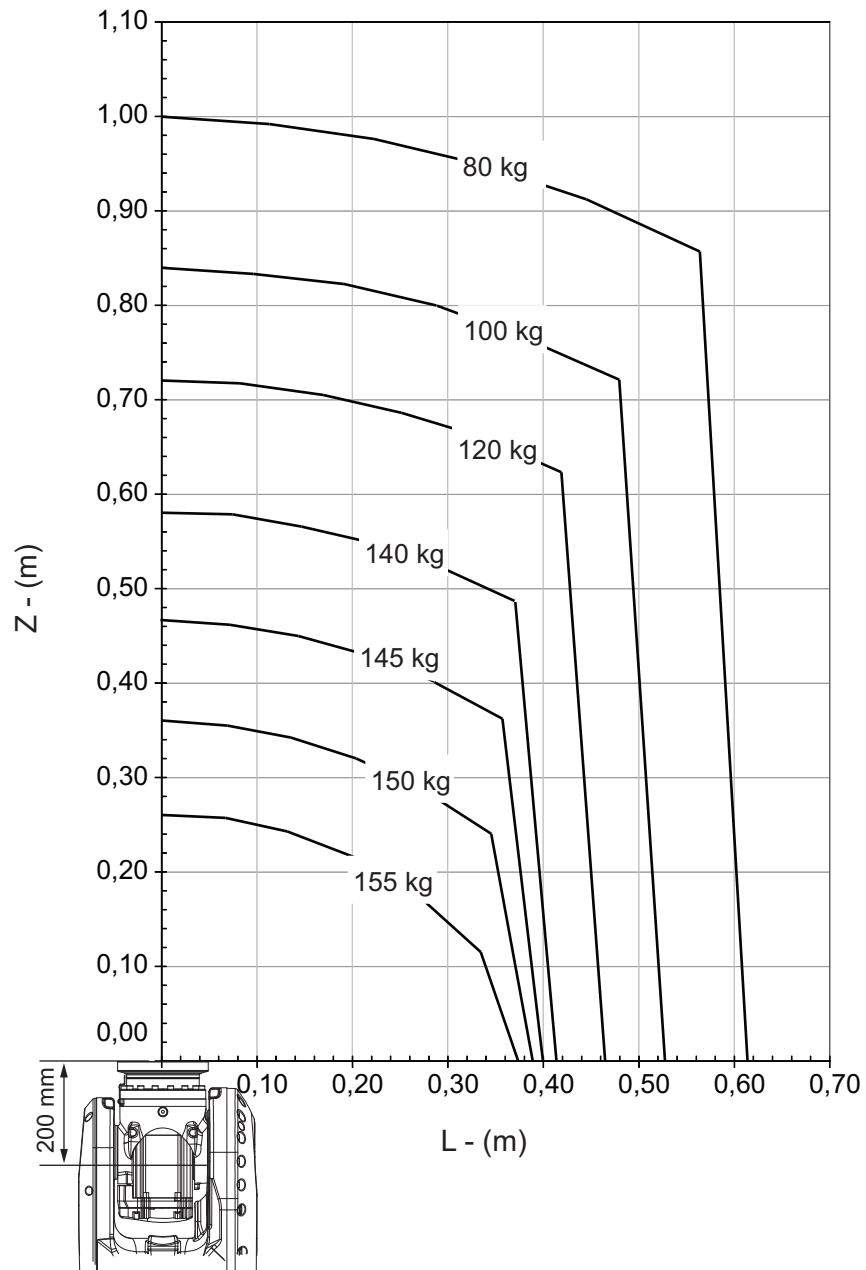

xx130000255

Continues on next page

1 Description

1.5.2 Diagrams

Continued

IRB 6700-150/3.20 "Vertical Wrist" ($\pm 10^\circ$)

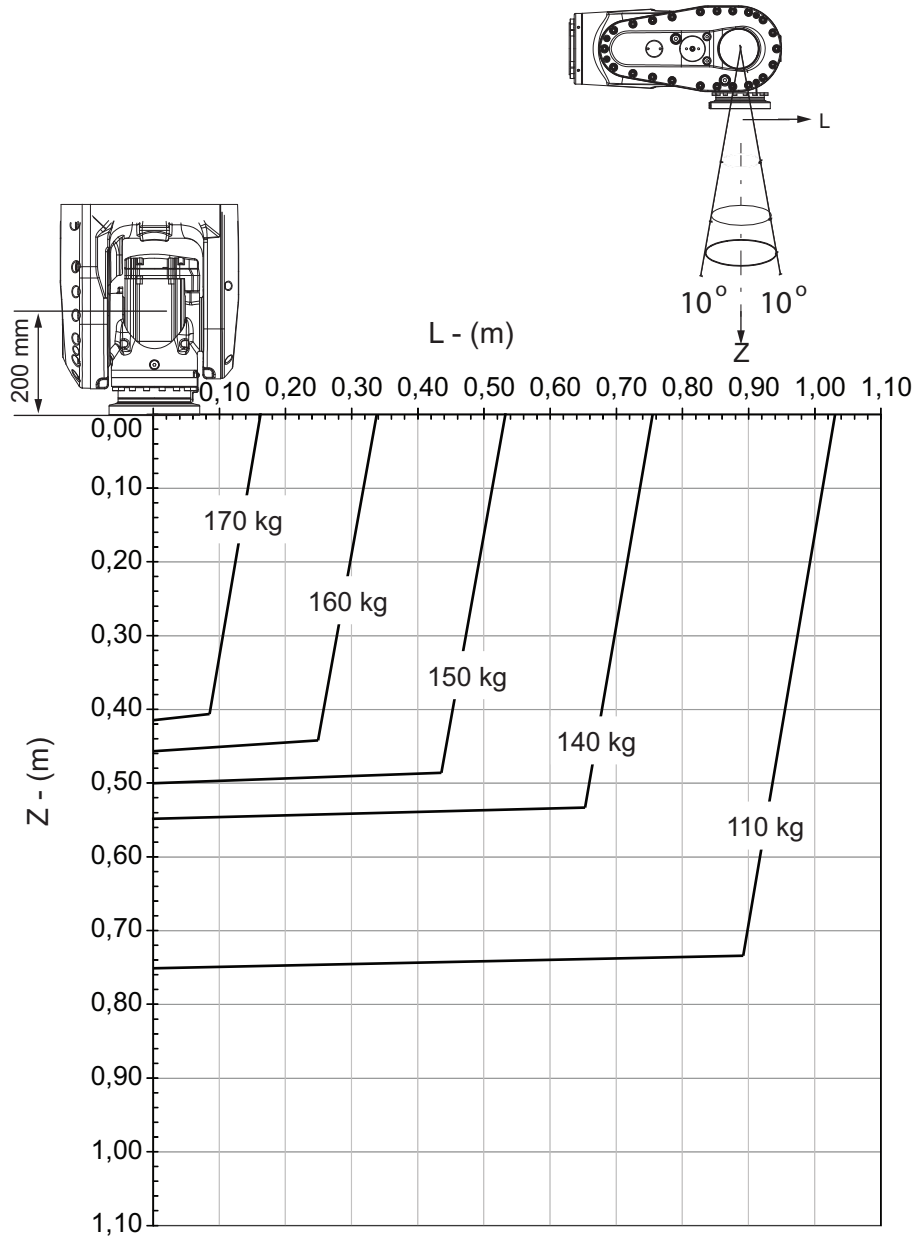

xx1300000256

For wrist down (0° deviation from the vertical line).

	Description
Max load	177 kg
Z _{max}	0.394 m
L _{max}	0.106 m

Continues on next page

IRB 6700-150/3.20 "LeanID", option 780-4

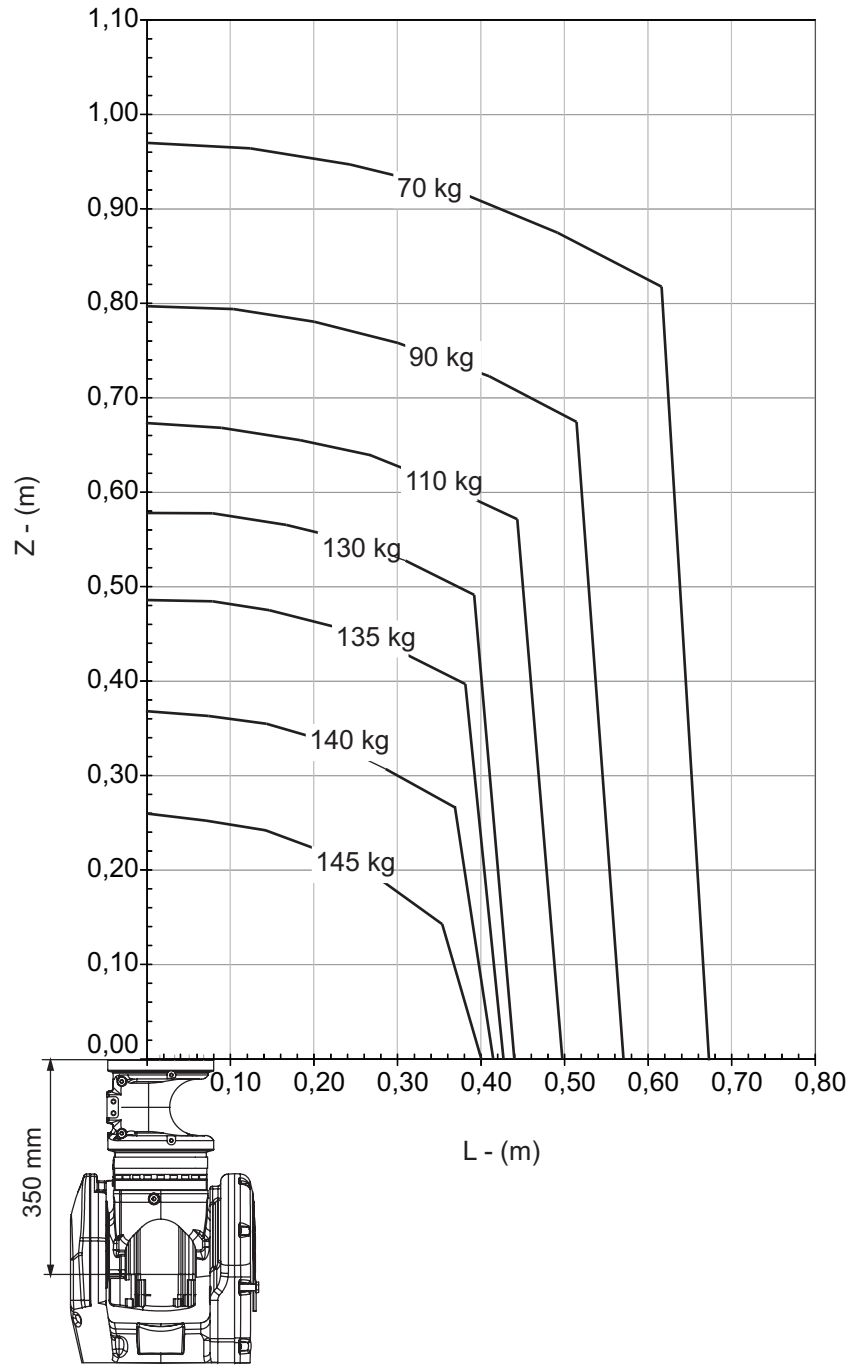

xx1300000257

Continues on next page

1 Description

1.5.2 Diagrams

Continued

IRB 6700-300/2.70

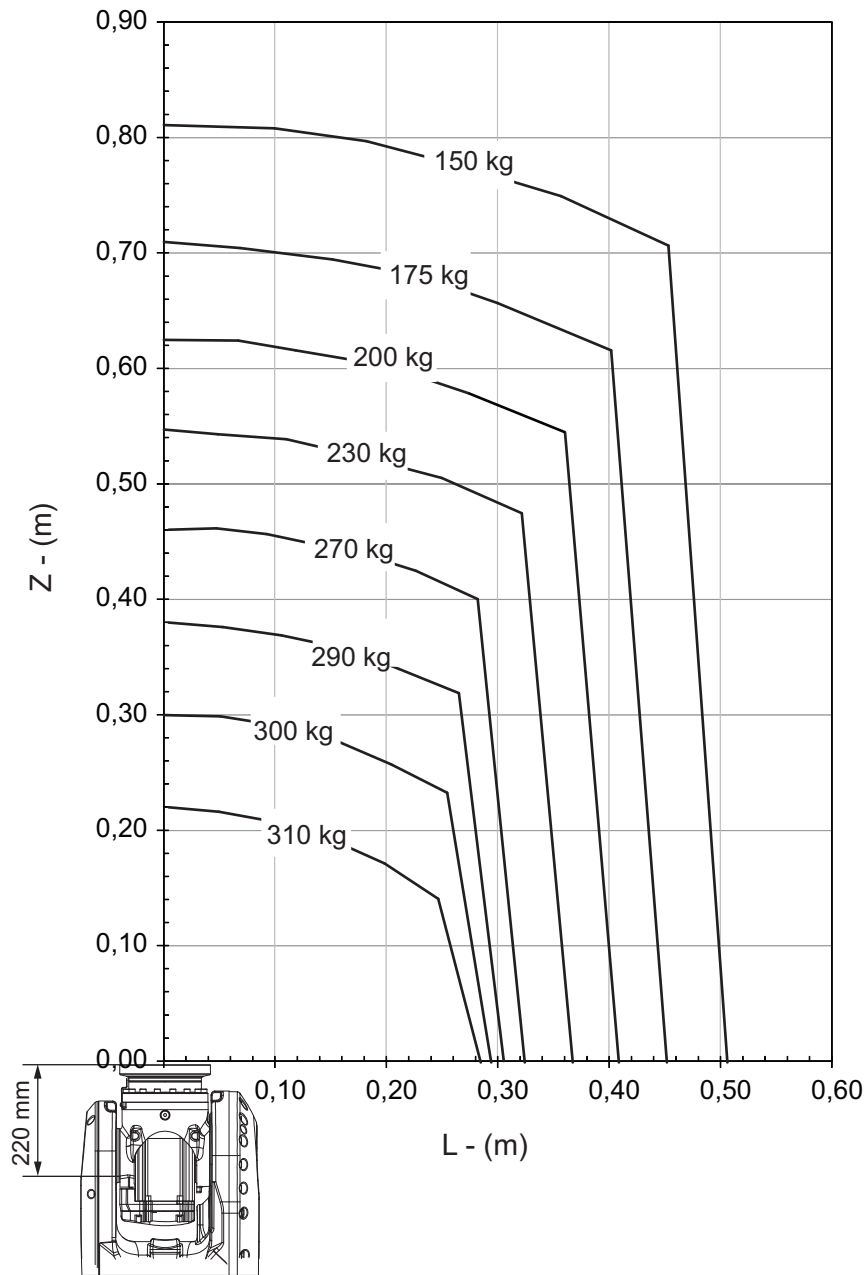

xx1400002044

Continues on next page

IRB 6700-300/2.70 "Vertical Wrist" ($\pm 10^\circ$)

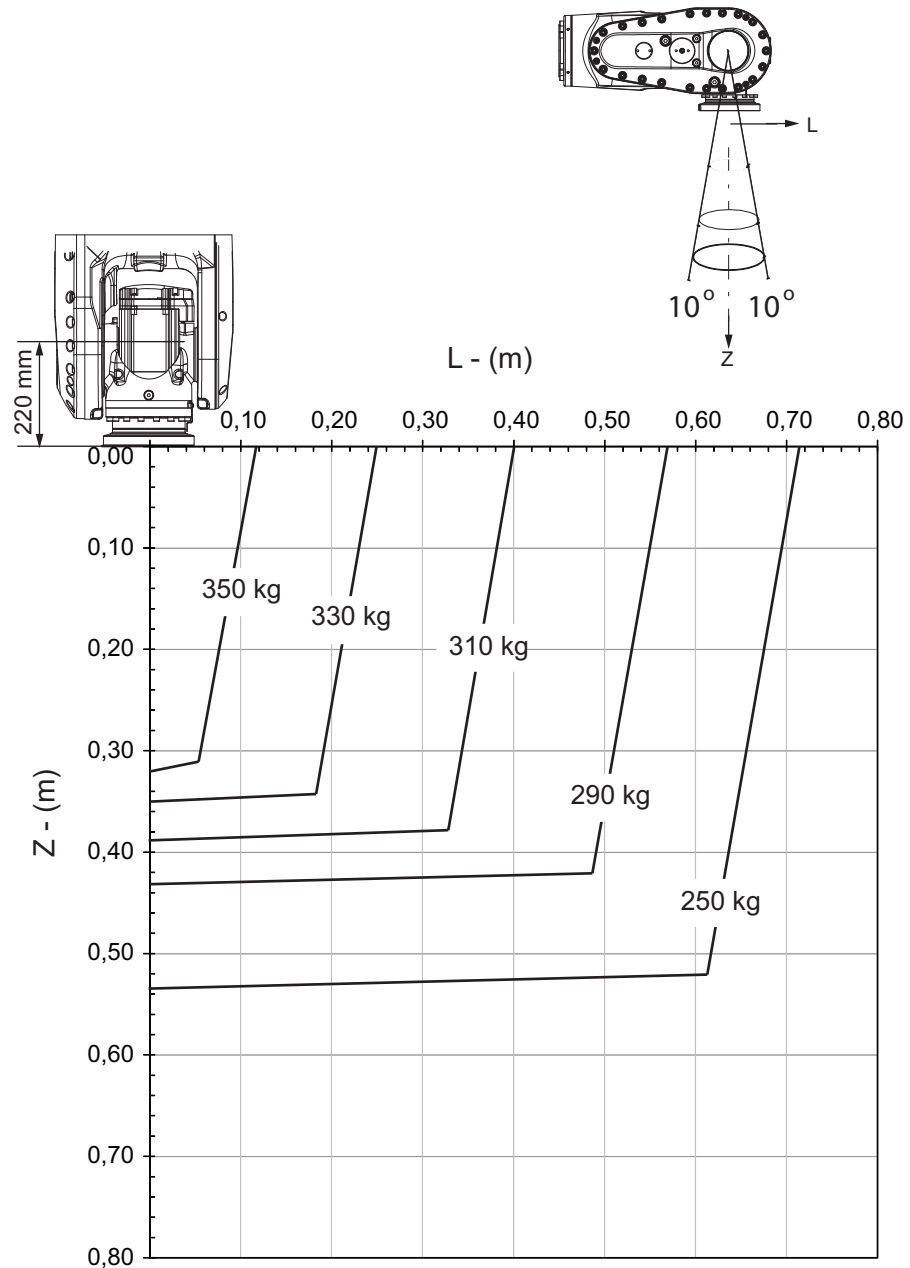

xx1400002045

For wrist down (0° deviation from the vertical line).

	Description
Max load	357 kg
Z _{max}	0.308 m
L _{max}	0.102 m

Continues on next page

1 Description

1.5.2 Diagrams

Continued

IRB 6700-300/2.70 "LeanID", option 780-4

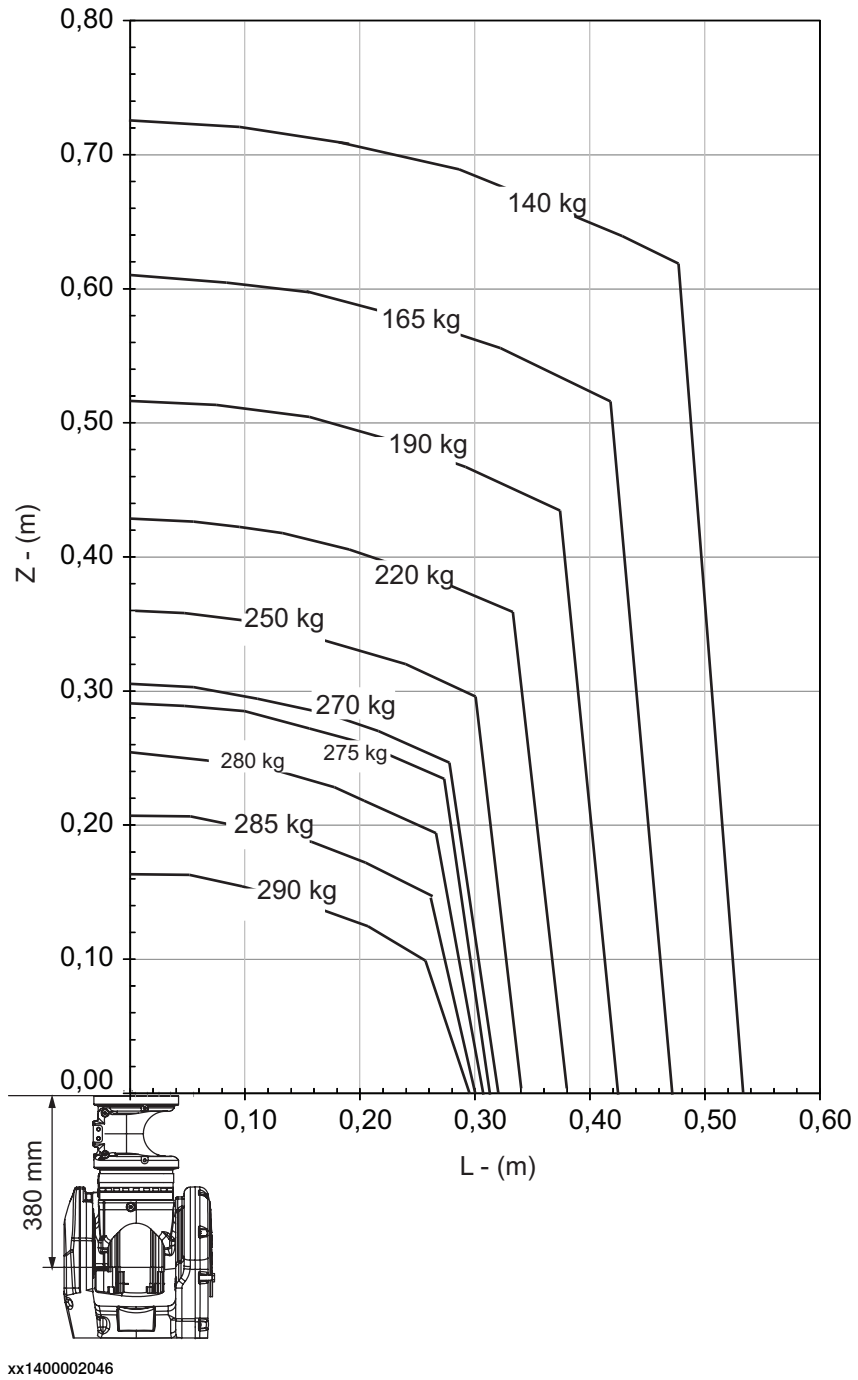

Continues on next page

IRB 6700-245/3.00

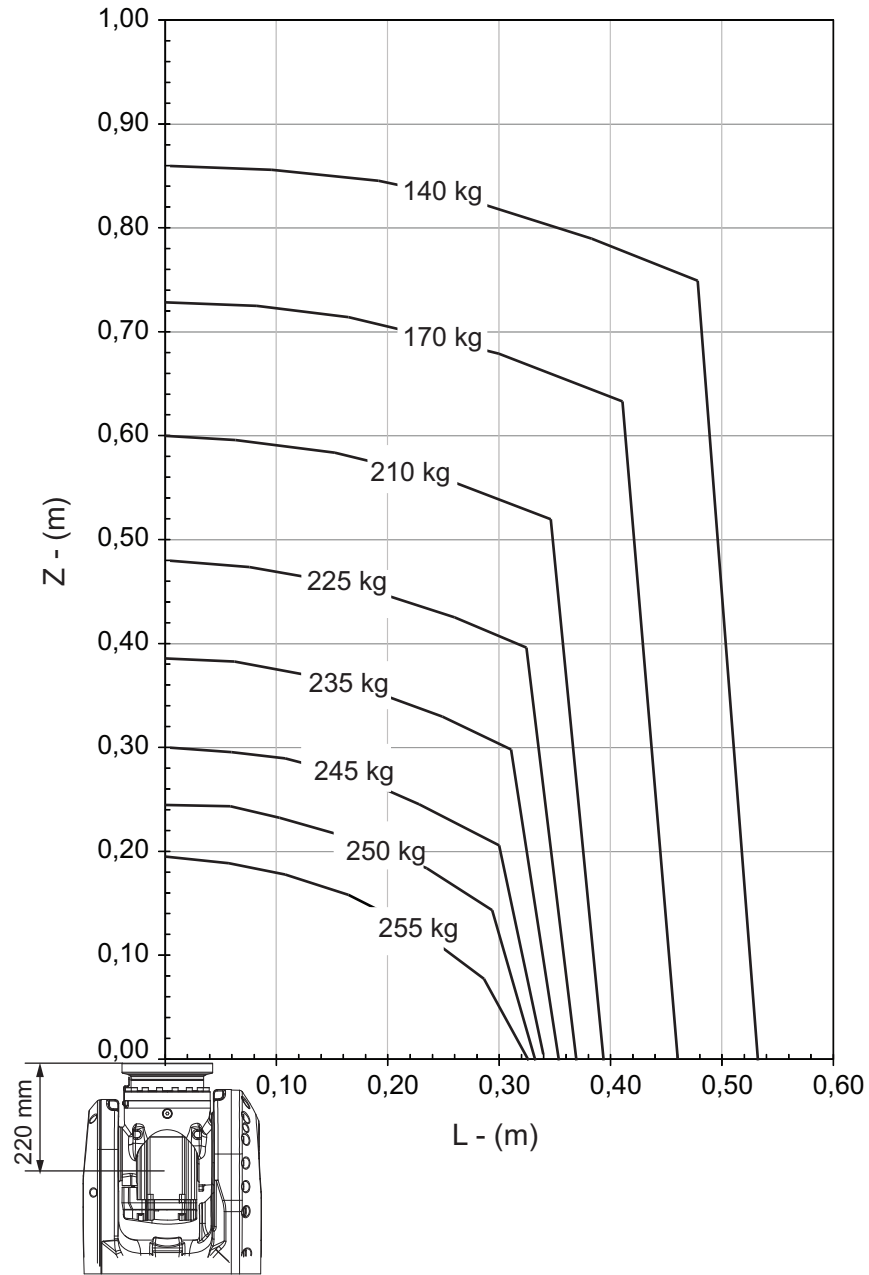

xx1400002041

Continues on next page

1 Description

1.5.2 Diagrams

Continued

IRB 6700-245/3.00 "Vertical Wrist" ($\pm 10^\circ$)

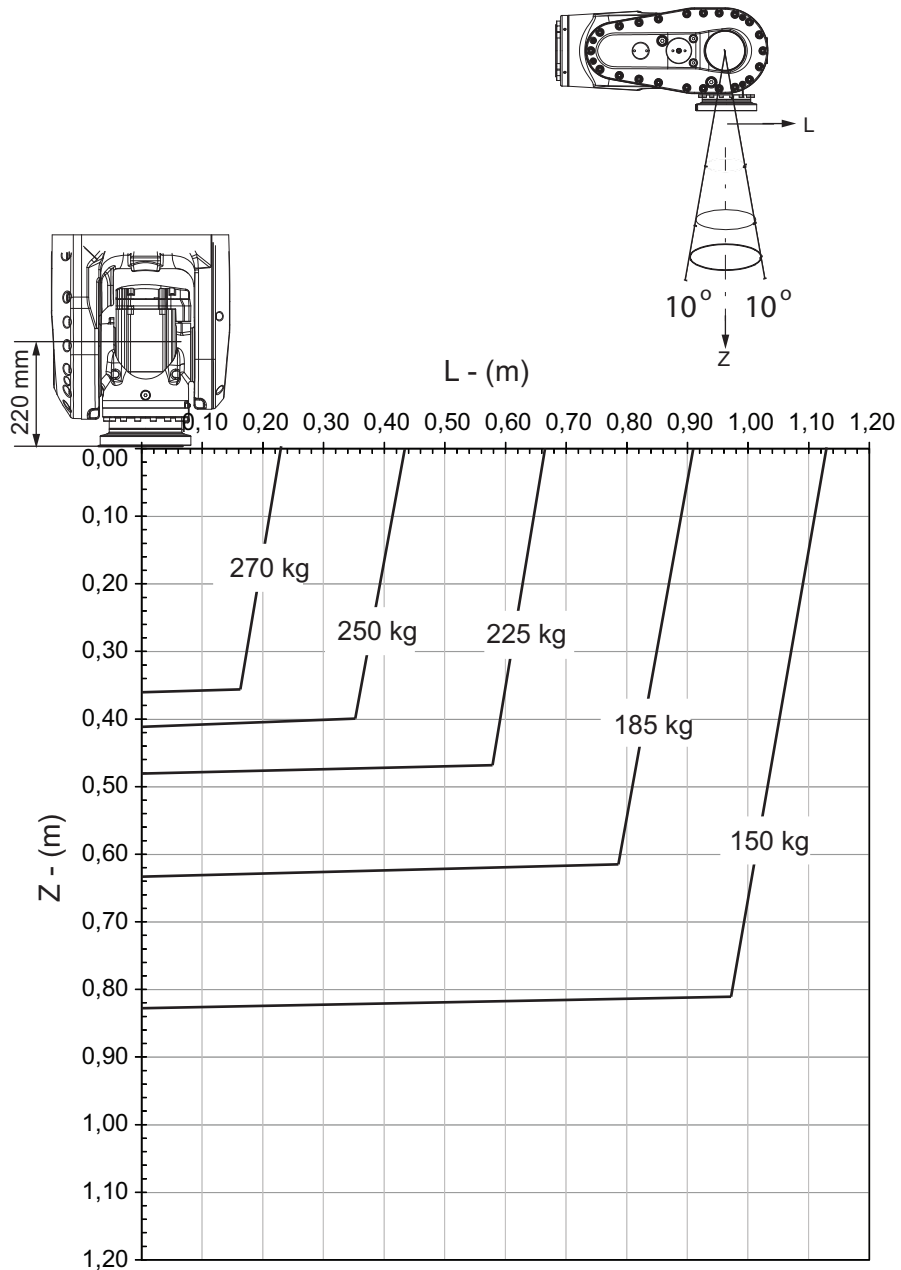

xx1400002042

For wrist down (0° deviation from the vertical line).

	Description
Max load	315 kg
Z _{max}	0.280 m
L _{max}	0.102 m

Continues on next page

IRB 6700-245/3.00 "LeanID", option 780-4

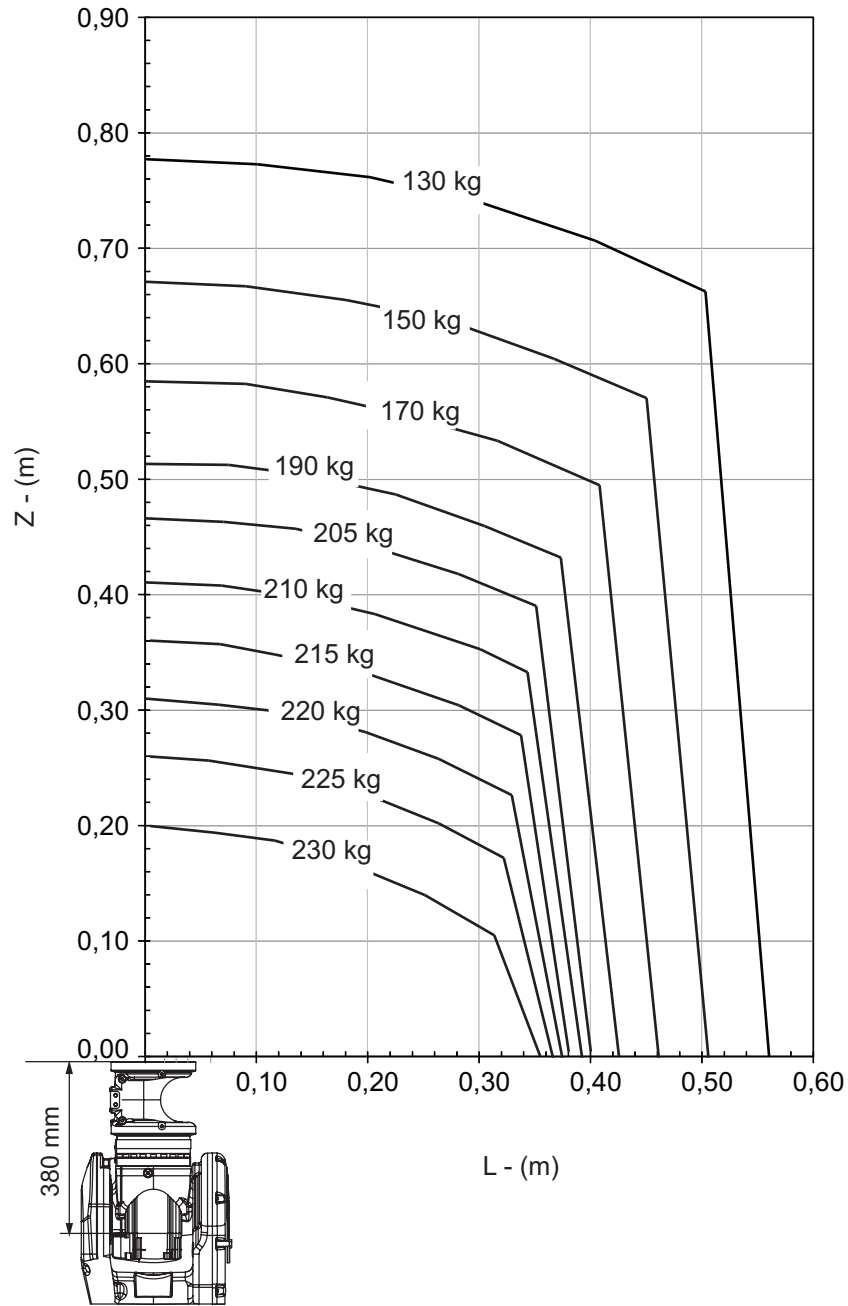

xx1400002043

Continues on next page

1 Description

1.5.2 Diagrams

Continued

IRB 6700Inv-300/2.60

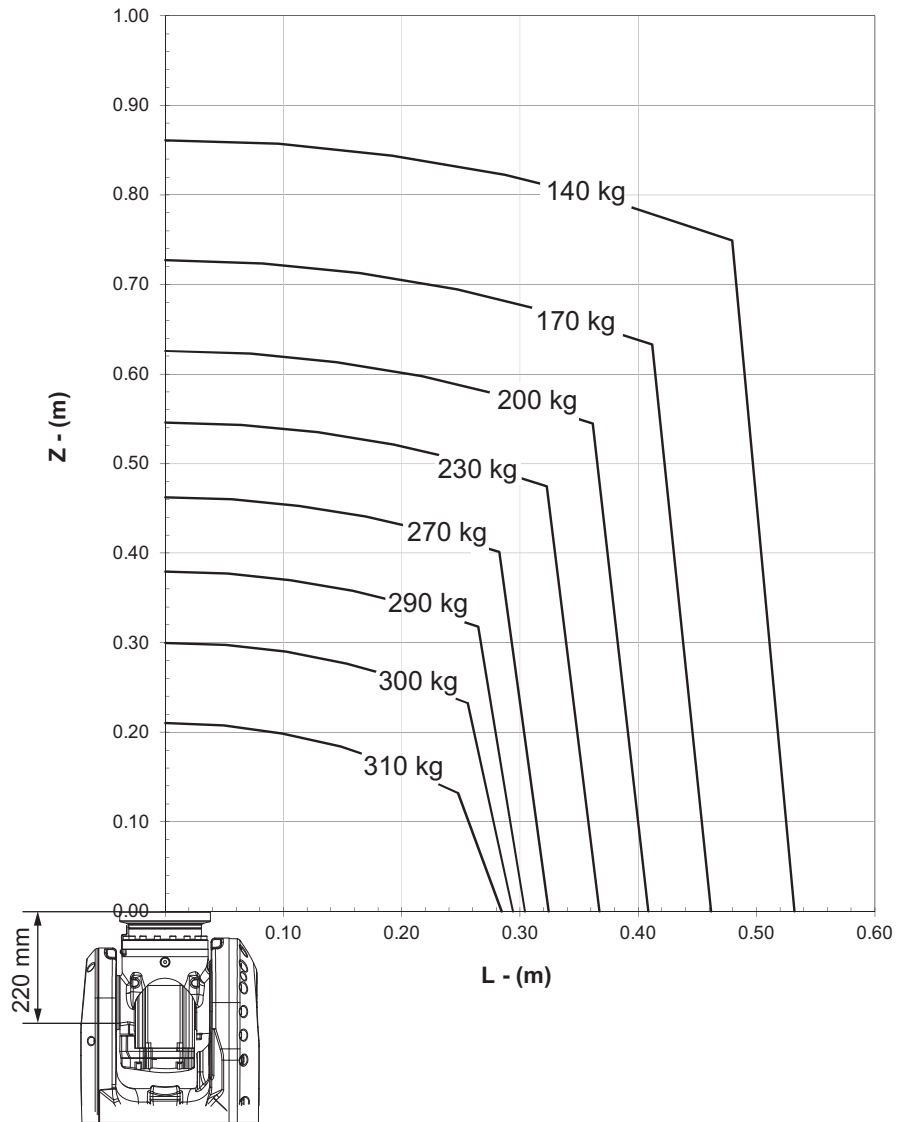

xx1600002017

Continues on next page

IRB 6700Inv-300/2.60 "Vertical Wrist" ($\pm 10^\circ$)

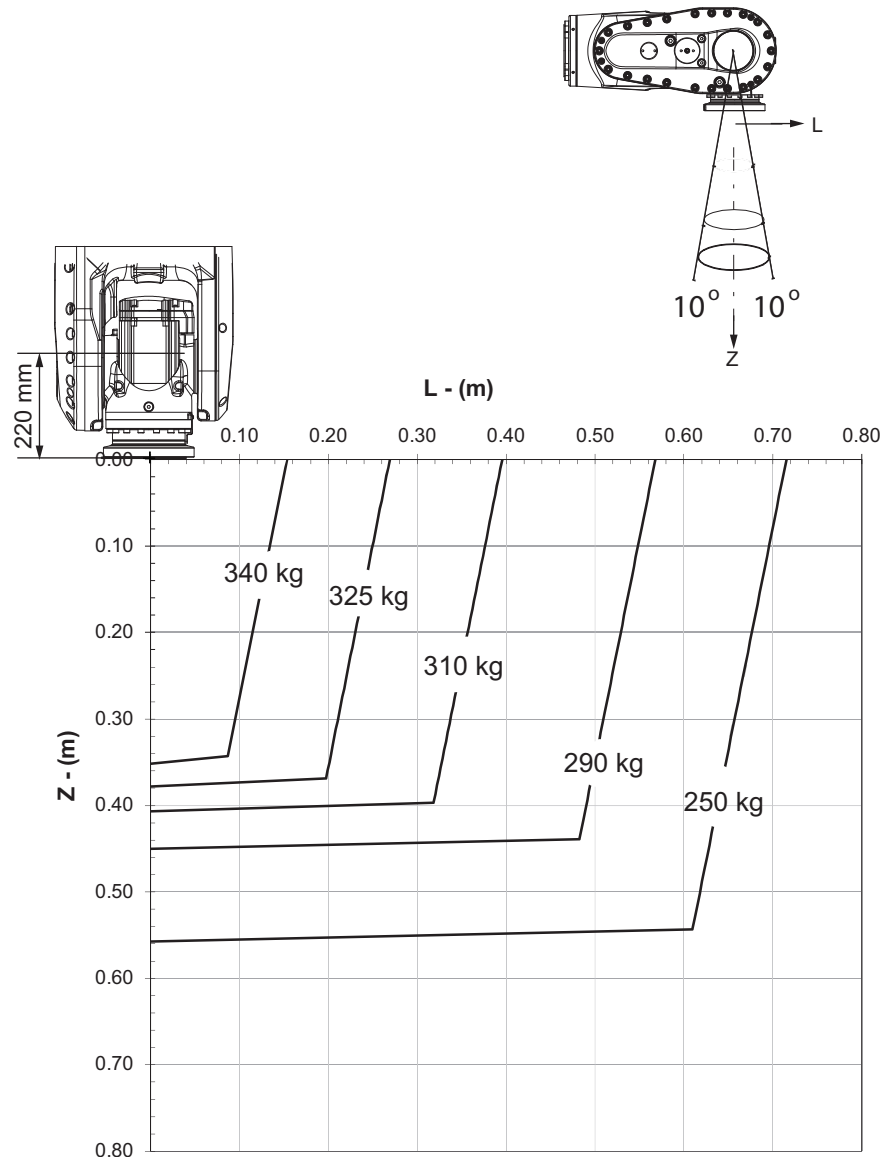

xx1600002018

For wrist down (0° deviation from the vertical line).

	Description
Max load	352 kg
Z _{max}	0.332 m
L _{max}	0.105 m

Continues on next page

1 Description

1.5.2 Diagrams

Continued

IRB 6700Inv-270/2.60 "LeanID", option 780-4

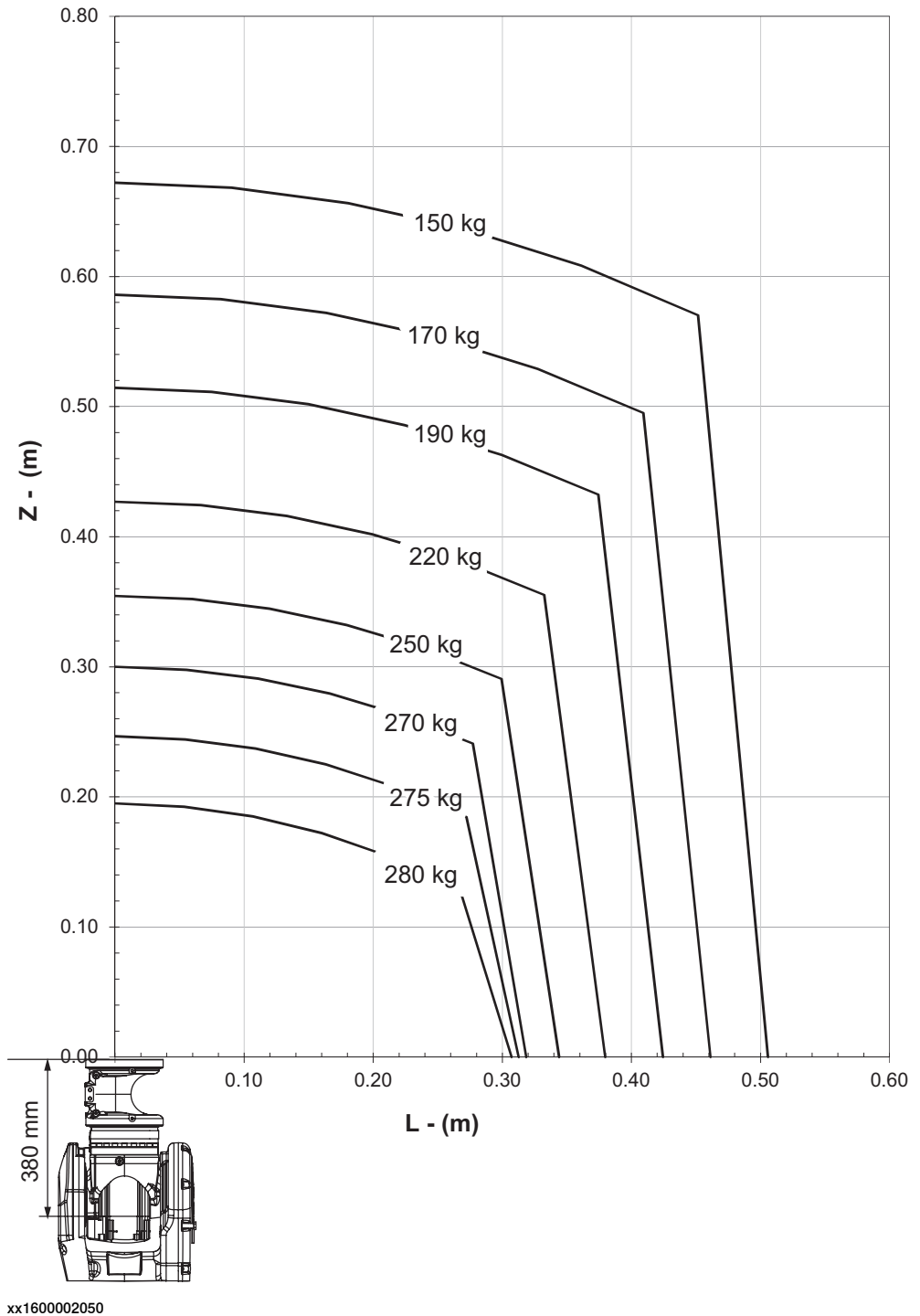

Continues on next page

IRB 6700Inv-245/2.90

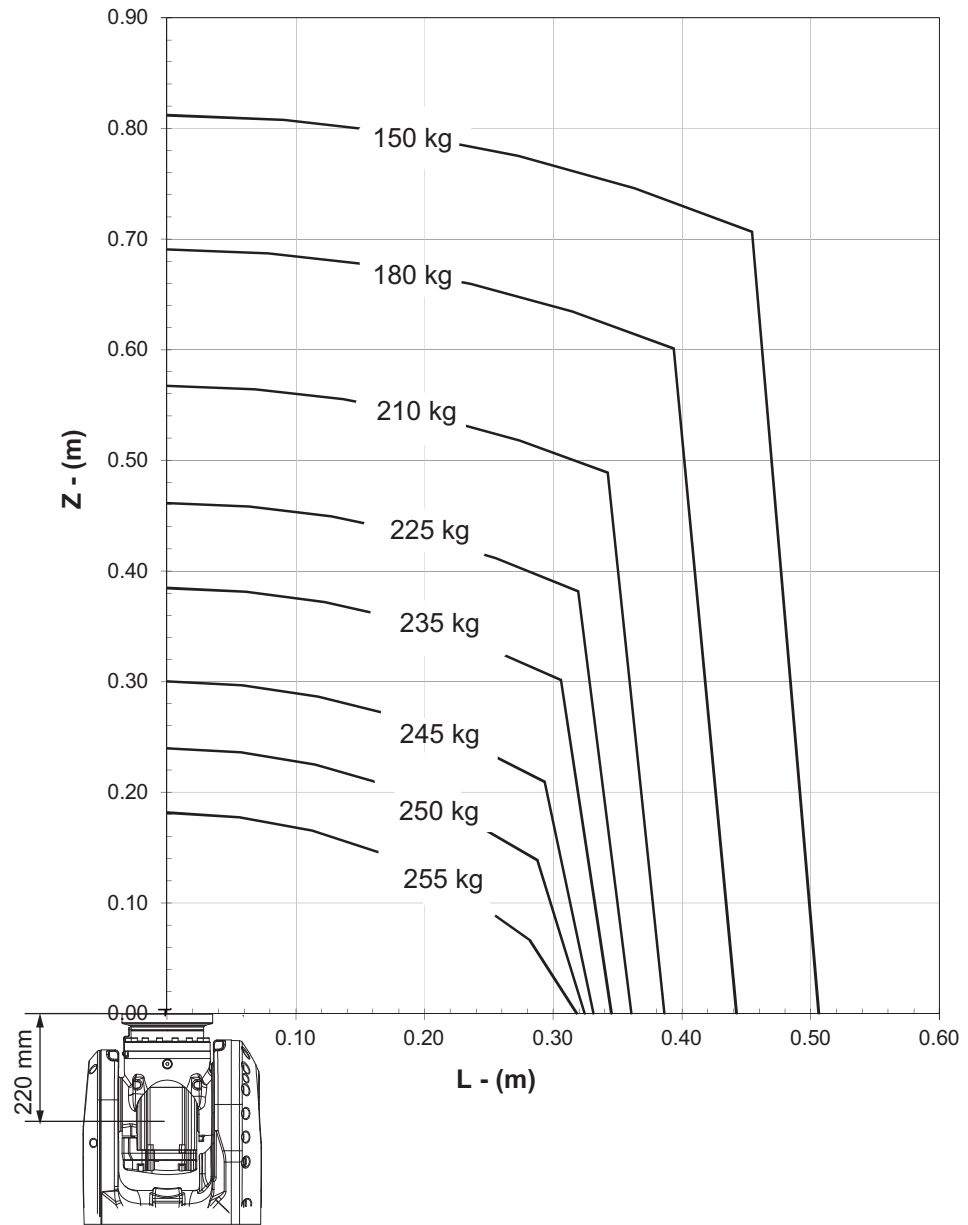

xx1600002019

Continues on next page

1 Description

1.5.2 Diagrams

Continued

IRB 6700Inv-245/2.90 "Vertical Wrist" ($\pm 10^\circ$)

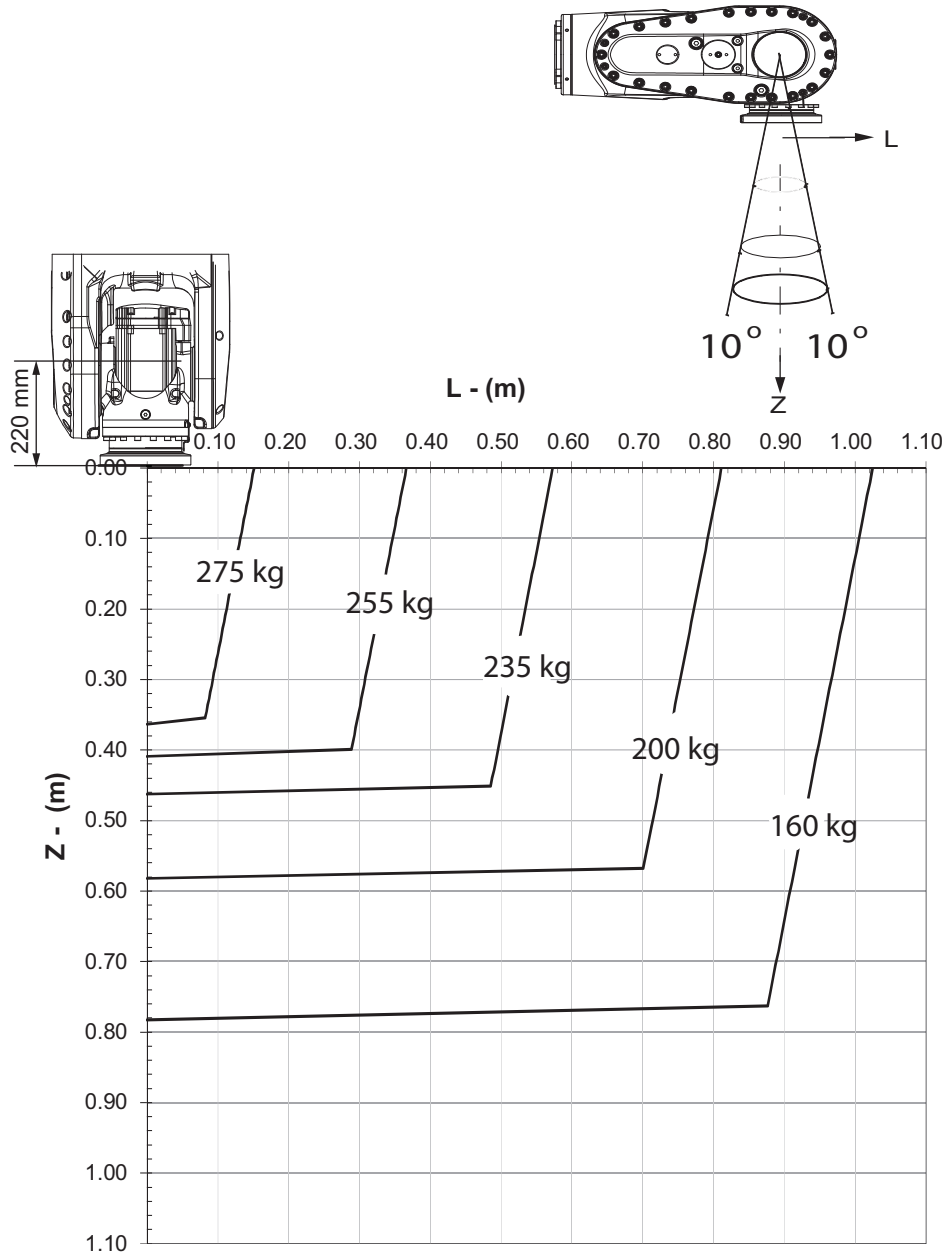

xx1600002020

For wrist down (0° deviation from the vertical line).

	Description
Max load	284 kg
Z _{max}	0.345 m
L _{max}	0.101 m

Continues on next page

IRB 6700Inv-210/2.90 "LeanID", option 780-4

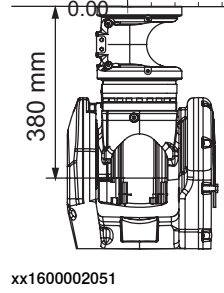
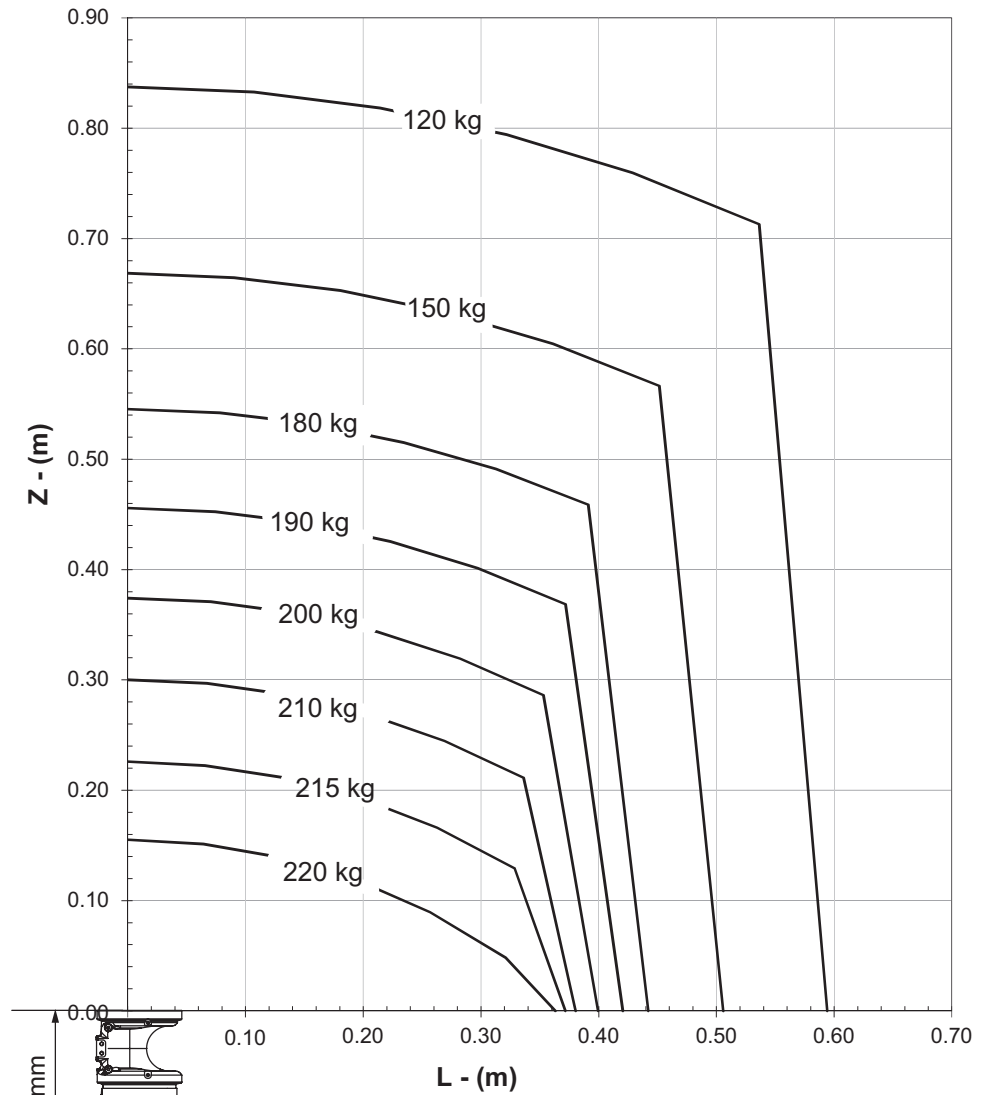

1 Description

1.5.3 Maximum load and moment of inertia for full and limited axis 5 (center line down) movement

1.5.3 Maximum load and moment of inertia for full and limited axis 5 (center line down) movement



Note

Total load given as: mass in kg, center of gravity (Z and L) in meters and moment of inertia (J_{ox} , J_{oy} , J_{oz}) in kgm^2 . $L = \text{sqr}(X^2 + Y^2)$, see the following figure.

Full movement of axis 5 ($\pm 130^\circ$)

Axis	Robot type	Maximum moment of inertia	
5	IRB 6700-235/2.65 IRB 6700-205/2.80 IRB 6700-175/3.05 IRB 6700-150/3.20	$Ja_5 = \text{Load} \times ((Z + 0,200^i)^2 + L^2) + \max(J_{0x}, J_{0y}) \leq 250 \text{ kgm}^2$	
	IRB 6700-200/2.60 IRB 6700-155/2.85	$Ja_5 = \text{Load} \times ((Z + 0,200^i)^2 + L^2) + \max(J_{0x}, J_{0y}) \leq 195 \text{ kgm}^2$	
	IRB 6700-300/2.70 IRB 6700-245/3.00 IRB 6700Inv-300/2.60 IRB 6700Inv-245/2.90	$Ja_5 = \text{Load} \times ((Z + 0,220^{ii})^2 + L^2) + \max(J_{0x}, J_{0y}) \leq 325 \text{ kgm}^2$	
	6	IRB 6700-235/2.65 IRB 6700-205/2.80 IRB 6700-175/3.05 IRB 6700-150/3.20	$Ja_6 = \text{Load} \times L^2 + J_{0z} \leq 185 \text{ kgm}^2$
		IRB 6700-200/2.60 IRB 6700-155/2.85	$Ja_6 = \text{Load} \times L^2 + J_{0z} \leq 145 \text{ kgm}^2$
		IRB 6700-300/2.70 IRB 6700-245/3.00 IRB 6700Inv-300/2.60 IRB 6700Inv-245/2.90	$Ja_6 = \text{Load} \times L^2 + J_{0z} \leq 225 \text{ kgm}^2$

i For option 780-4, LeanID = 0,350 m

ii For option 780-4, LeanID = 0,380 m

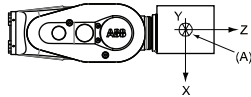

xx1400002028

Pos	Description
A	Center of gravity
Description	
J_{ox} , J_{oy} , J_{oz}	Max. moment of inertia around the X, Y and Z axes at center of gravity.

Continues on next page

1.5.3 Maximum load and moment of inertia for full and limited axis 5 (center line down) movement Continued

Limited axis 5, center line down

Axis	Robot type	Maximum moment of inertia
5	IRB 6700-235/2.65 IRB 6700-205/2.80 IRB 6700-175/3.05 IRB 6700-150/3.20	$Ja_5 = \text{Load} \times ((Z + 0,200^i)^2 + L^2) + \max(J_{0x}, J_{0y}) \leq 275 \text{ kgm}^2$
	IRB 6700-200/2.60 IRB 6700-155/2.85	$Ja_5 = \text{Load} \times ((Z + 0,200^i)^2 + L^2) + \max(J_{0x}, J_{0y}) \leq 215 \text{ kgm}^2$
	IRB 6700-300/2.70 IRB 6700-245/3.00 IRB 6700Inv-300/2.60 IRB 6700Inv-245/2.90	$Ja_5 = \text{Load} \times ((Z + 0,220^{ii})^2 + L^2) + \max(J_{0x}, J_{0y}) \leq 360 \text{ kgm}^2$
6	IRB 6700-235/2.65 IRB 6700-205/2.80 IRB 6700-175/3.05 IRB 6700-150/3.20	$Ja_6 = \text{Load} \times L^2 + J_{0z} \leq 250 \text{ kgm}^2$
	IRB 6700-200/2.60 IRB 6700-155/2.85	$Ja_6 = \text{Load} \times L^2 + J_{0z} \leq 195 \text{ kgm}^2$
	IRB 6700-300/2.70 IRB 6700-245/3.00 IRB 6700Inv-300/2.60 IRB 6700Inv-245/2.90	$Ja_6 = \text{Load} \times L^2 + J_{0z} \leq 320 \text{ kgm}^2$

- i For option 780-4, LeanID = 0,350 m
ii For option 780-4, LeanID = 0,380 m

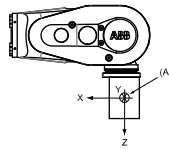

xx1400002029

Pos	Description
A	Center of gravity
	Description
J_{0x}, J_{0y}, J_{0z}	Max. moment of inertia around the X, Y and Z axes at center of gravity.

1 Description

1.5.4 Wrist torque

1.5.4 Wrist torque



Note

The wrist torque values are for reference only, and should not be used for calculating permitted load offset (position of center of gravity) within the load diagram, since those also are limited by main axes torques as well as dynamic loads. Furthermore, arm loads will influence the permitted load diagram. To find the absolute limits of the load diagram, use the RobotStudio add-in RobotLoad.

Torque

The table below shows the maximum permissible torque due to payload.

Robot type	Max wrist torque axis 4 and 5	Max wrist torque axis 6	Max torque valid at load
IRB 6700 - 235/2.65	1,324 Nm	650 Nm	225 kg
IRB 6700 - 205/2.80	1,263 Nm	625 Nm	192 kg
IRB 6700 - 200/2.60	981 Nm	429 Nm	175 kg
IRB 6700 - 175/3.05	1,179 Nm	589 Nm	154 kg
IRB 6700 - 155/2.85	927 Nm	410 Nm	144 kg
IRB 6700 - 150/3.20	1,135 Nm	570 Nm	137 kg
IRB 6700 - 300/2.70	1,825 Nm	865 Nm	280 kg
IRB 6700 - 245/3.00	1,693 Nm	815 Nm	214 kg
IRB 6700INV - 300/2.60	1,825 Nm	865 Nm	280 kg
IRB6700I - 245/2.90	1,645 Nm	796 Nm	194 kg

1.5.5 Maximum TCP acceleration

General

Higher values can be reached with lower loads than the nominal because of our dynamical motion control QuickMove2. For specific values in the unique customer cycle, or for robots not listed in the table below, we recommend then to use RobotStudio.

Maximum Cartesian design acceleration for nominal loads

Robot type	E-stop Max acceleration at nominal load COG [m/s ²]	Controlled Motion Max acceleration at nominal load COG [m/s ²]
IRB 6700 - 235/2.65	41	22
IRB 6700 - 205/2.8	45	24
IRB 6700 - 175/3.05	42	25
IRB 6700 - 150/3.2	47	24
IRB 6700 - 200/2.6	51	23
IRB 6700 - 155/2.85	47	29
IRB 6700 - 300/2.7	39	21
IRB 6700 - 245/3.0	44	27



Note

Acceleration levels for emergency stop and controlled motion includes acceleration due to gravitational forces. Nominal load is defined with nominal mass and cog with max offset in Z and L (see the load diagram).

1 Description

1.6 Fitting equipment to the robot

1.6 Fitting equipment to the robot

General

Extra loads can be fitted on the upper arm housing, the lower arm, and on the frame. Definitions of distances and masses are shown in the following figures. The robot is supplied with holes for fitting extra equipment (see figure in [Holes for fitting extra equipment on page 75](#)). Maximum allowed arm load depends on center of gravity of arm load and robot payload.



Note

All equipment and cables used on the robot, must be designed and fitted not to damage the robot and/or its parts.

Frame (hip load)

Extra load can be fitted on the frame.

	Description
Permitted extra load on frame	$J_H = 100 \text{ kgm}^2$
Recommended position (see the following figure)	$J_H = J_{H0} + M4 \times R^2$ where: <ul style="list-style-type: none">• J_{H0} is the moment of inertia of the equipment• R is the radius (m) from the center of axis 1• $M4$ is the total mass (kg) of the equipment including bracket and harness ($\leq 250 \text{ kg}$)

Continues on next page

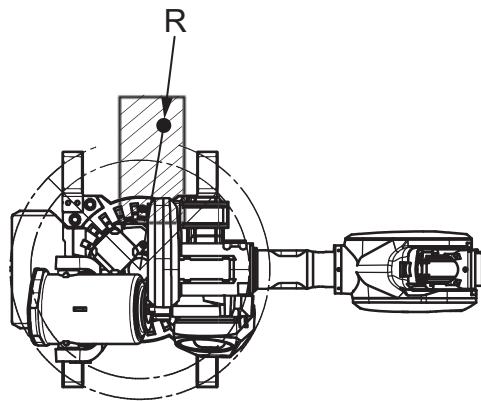
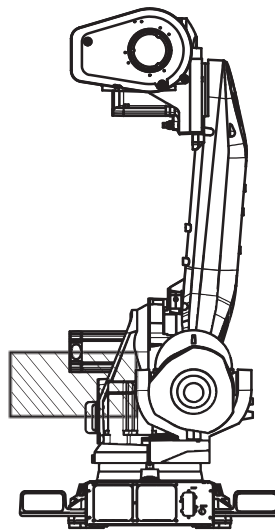

xx130000262

Upper arm

Allowed extra load on the upper arm housing, in addition to the maximum handling weight, is $M1 \leq 50$ kg with a distance (a) ≤ 500 mm from the center of gravity in the axis-3 extension.

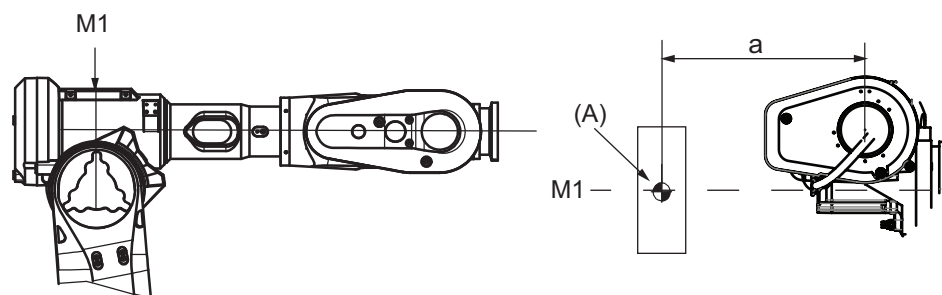

xx1400002019

A	Mass center
---	-------------

Continues on next page

1 Description

1.6 Fitting equipment to the robot

Continued

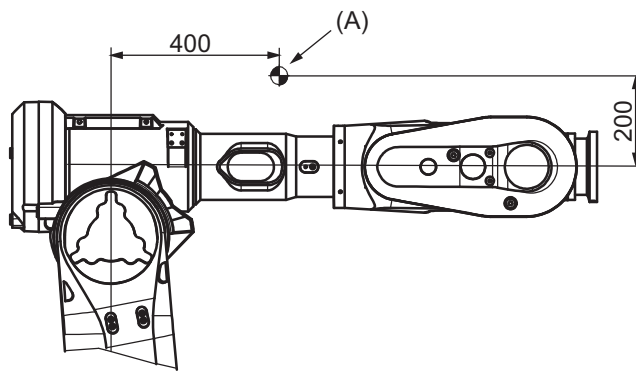

xx130000866

A	Center of gravity 50 kg
---	-------------------------

Continues on next page

Holes for fitting extra equipment

Position of attachment holes - drawing 1

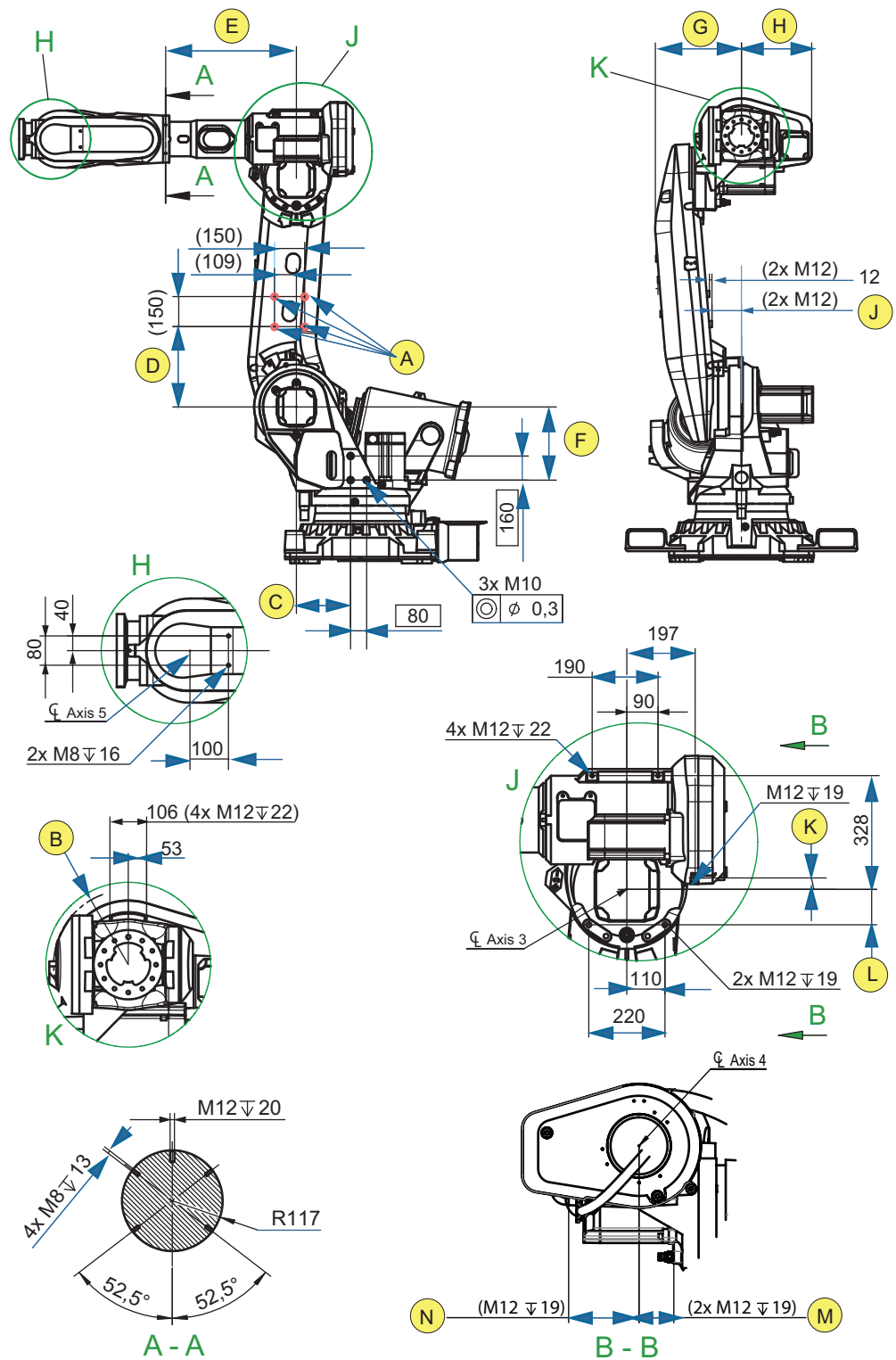

xx1300000263

A	Allowed position for attachment holes, M12 through. Be careful not to touch the cables when drilling.
---	---

Continues on next page

1 Description

1.6 Fitting equipment to the robot

Continued

Variant	B ⁱ	C	D	E	F	G	H	J	K	L	M	N
IRB 6700 - 235/2.65	R=216	270	400	652.5	365	437	349	147	33	102	104	210
IRB 6700 - 205/2.80	R=216	270	500	652.5	365	437	349	147	33	102	104	210
IRB 6700 - 175/3.05	R=216	270	400	652.5	365	437	349	147	33	102	104	210
IRB 6700 - 150/3.20	R=216	270	500	652.5	365	437	349	147	33	102	104	210
IRB 6700 - 200/2.60	R=204.5	270	400	650.5	365	437	315	143	43	102	95	210
IRB 6700 - 155/2.85	R=204.5	270	400	650.5	365	437	315	143	43	102	95	210
IRB 6700 - 300/2.70	R=230	310	450	652.5	376	467	405	152	12	117	98.5	215.5
IRB 6700 - 245/3.00	R=230	310	450	652.5	376	467	405	152	12	117	98.5	215.5
IRB 6700Inv - 300/2.60	R=230	310	450	652.5	425.6	467	405	152	12	117	98.5	215.5
IRB 6700Inv - 245/2.90	R=230	310	450	652.5	425.6	467	405	152	12	117	98.5	215.5

ⁱ Smallest circumscribed radius axis-4.

Continues on next page

Position of attachment holes - drawing 2

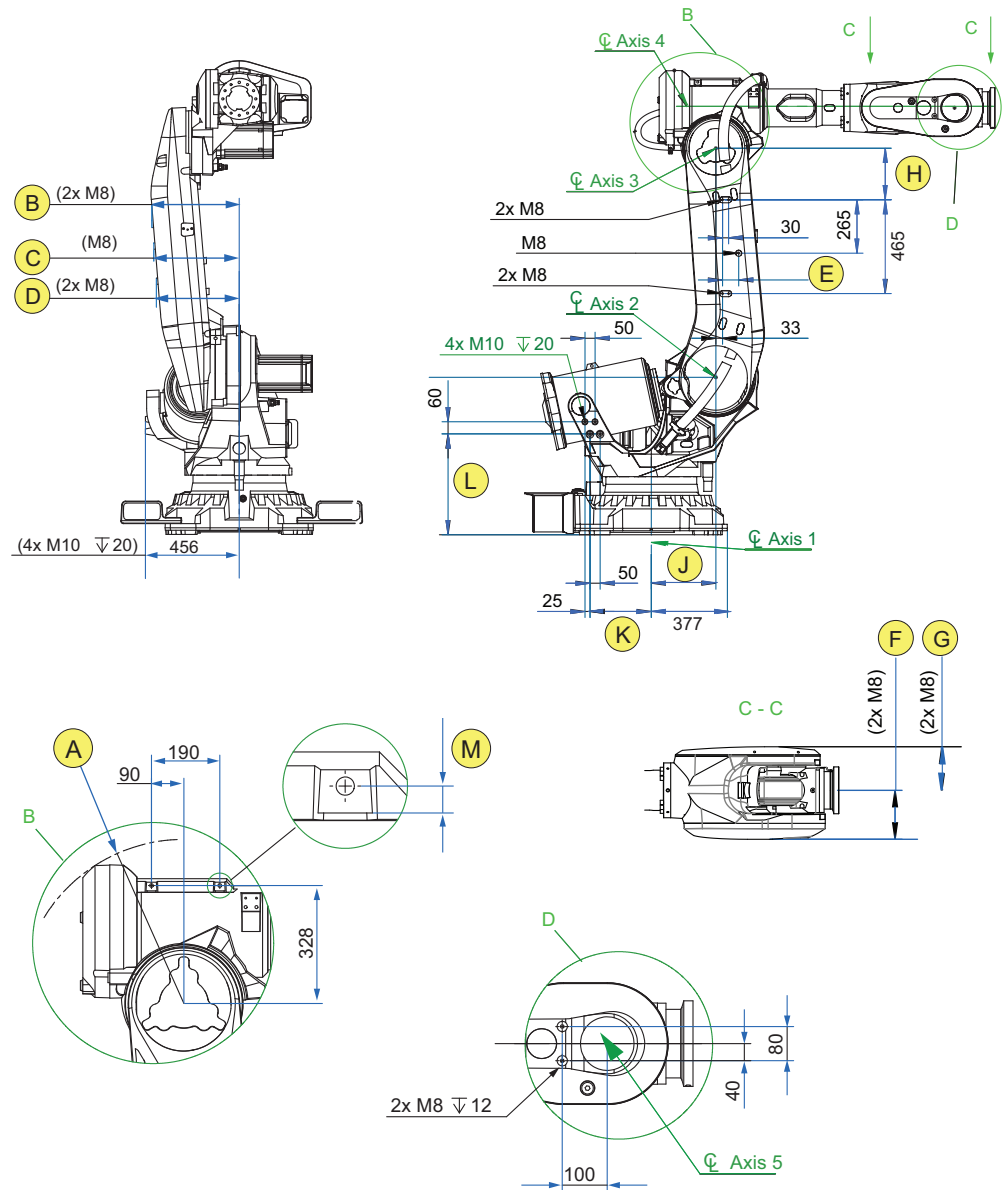

xx130000264

Variant	A ⁱ	B	C	D	E	F	G	H	J	K	L	M
IRB 6700 - 235/2.65	R=456	433	418	403	80	208.5	186	255	320	303.5	500	13.8
IRB 6700 - 205/2.80	R=456	438	423	408	80	208.5	186	255	320	303.5	500	13.8
IRB 6700 - 175/3.05	R=456	433	418	403	80	208.5	186	255	320	303.5	500	13.8
IRB 6700 - 150/3.20	R=456	438	423	408	80	208.5	186	255	320	303.5	500	13.8
IRB 6700 - 200/2.60	R=440	425	410	395	113	197	193	255	320	303.5	500	13.8
IRB 6700 - 155/2.85	R=440	425	410	395	113	197	193	255	320	303.5	500	13.8
IRB 6700 - 245/3.00	R=468	453	438	423	80	222.5	187	265	350	273.5	523.5	15
IRB 6700 - 300/2.70	R=468	453	438	423	80	222.5	187	265	350	273.5	523.5	15
IRB 6700Inv - 300/2.60	R=468	453	438	423	80	222.5	187	265	350	273.5	523.5	15

Continues on next page

1 Description

1.6 Fitting equipment to the robot

Continued

Variant	A ⁱ	B	C	D	E	F	G	H	J	K	L	M
IRB 6700Inv - 245/2.90	R=468	453	438	423	80	222.5	187	265	350	273.5	523.5	15

ⁱ Smallest circumscribed radius axis-3.

Continues on next page

Tool flange, standard

Below is the standard tool flange. The guide pin hole is, in calibration position, pointing upwards in Z-direction.

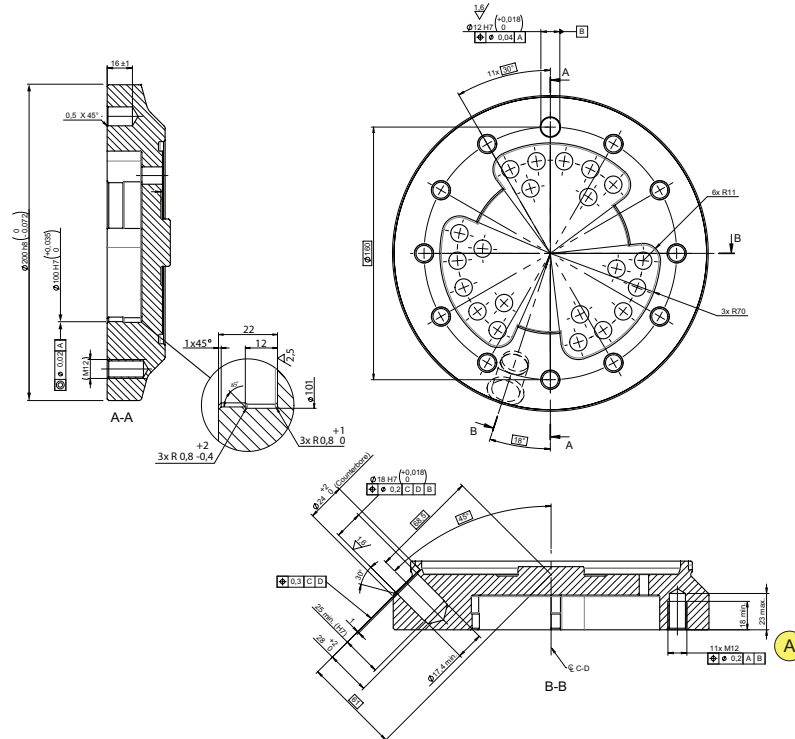

xx130000280

A	Thread length: 18 mm.
---	-----------------------

The turning disc for robot variants IRB 6700 - 200/2.60 and IRB 6700 - 155/2.85 was redesigned when Axis Calibration was introduced for IRB 6700. Prior to Axis Calibration the holes on the disc were through. On the current turning disc the holes are not through.

Continues on next page

1 Description

1.6 Fitting equipment to the robot

Continued

Tool flange, LeanID

Below is the tool flange for option 780-4, LeanID

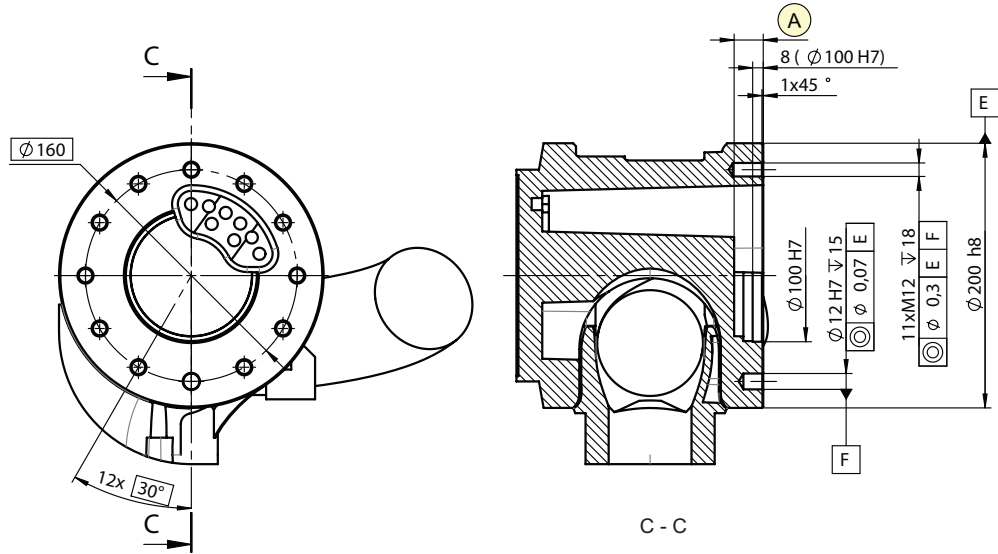

xx1300000290

A	Thread length: 18 mm.
---	-----------------------

Fastener quality

When fitting tools on the tool flange, only use screws with quality 12.9. For other equipment use suitable screws and tightening torque for your application.

1.7 Maintenance and troubleshooting

General

The robot requires only minimum maintenance during operation. It has been designed to make it as easy to service as possible:

- Maintenance-free AC motors are used.
- Oil is used for the gearboxes.
- The cabling is routed for longevity, and in the unlikely event of a failure, its modular design makes it easy to change.

Maintenance

The maintenance intervals depend on the use of the robot. The required maintenance activities also depend on the selected options. For detailed information on maintenance procedures, see the maintenance section in product manuals.

1 Description

1.8.1 Robot motion

1.8 Robot motion

1.8.1 Robot motion

Type of motion

Axis	Type of motion	Range of movement - IRB 6700	Range of movement - IRB 6700Inv	Note
Axis 1	Rotation motion	$\pm 170^\circ$ or $\pm 220^\circ$ (option)	$\pm 170^\circ$	
Axis 2	Arm motion	$-65^\circ/+85^\circ$ ⁱ	$\pm 65^\circ$ ⁱⁱ	
Axis 3	Arm motion	$-180^\circ/+70^\circ$	-180° ⁱⁱ / $+70^\circ$ ⁱⁱ	
Axis 4	Wrist motion	$\pm 300^\circ$	$\pm 300^\circ$	
Axis 5	Bend motion	$\pm 130^\circ$ ⁱⁱⁱ	$\pm 130^\circ$ ⁱⁱⁱ	
Axis 6	Turn motion	$\pm 360^\circ$ ^{iv}	$\pm 360^\circ$ ^{iv}	
		± 93.7 revolutions	± 93.7 revolutions	Maximum value. The default working range for axis 6 can be extended by changing parameter values in the software. Option 610-1 <i>Independent axis</i>

ⁱ Working range for variants IRB 6700 - 300/2.70 and - 245/3.00:

+85° to -65° when axis 3 is within +70° to -45°

+85° to -58° when axis 3 is within +70° to -180°

ⁱⁱ Working ranges of axis 2 and axis 3 are limited in some areas to avoid collision with balancing.

ⁱⁱⁱ Working range +120° to -120° for robots with LeanID, option 780-4

^{iv} Working range +220° to -220° for robots with LeanID, option 780-4

Continues on next page

Working range axis 2 and axis 3 for IRB 6700-300/2.70 and -245/3.00

Limited in some areas to avoid collision with balancing.

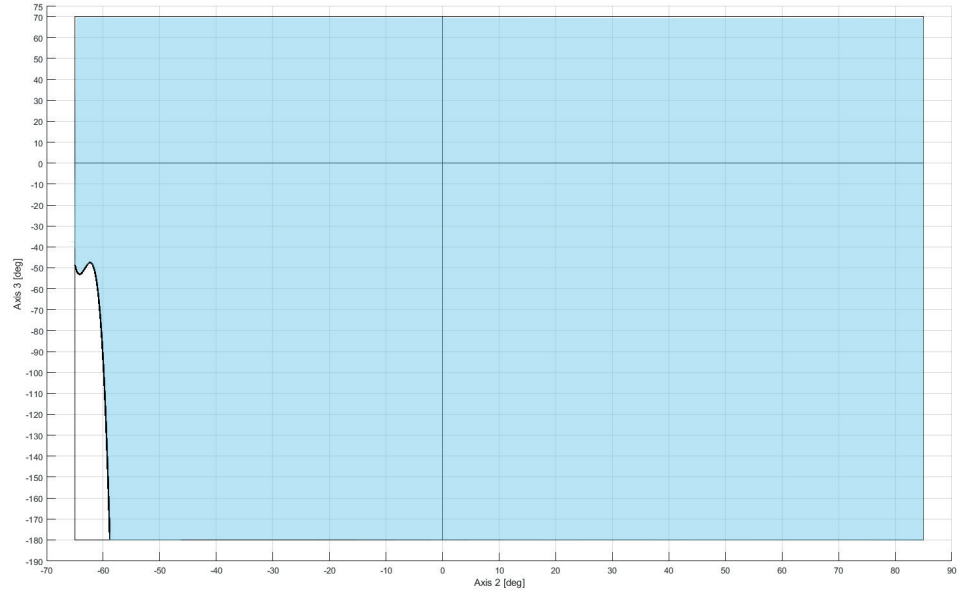

xx170000509

Working range axis 2 and axis 3 for IRB 6700Inv-300/2.60 and -245/2.90

Limited in some areas to avoid collision with balancing.

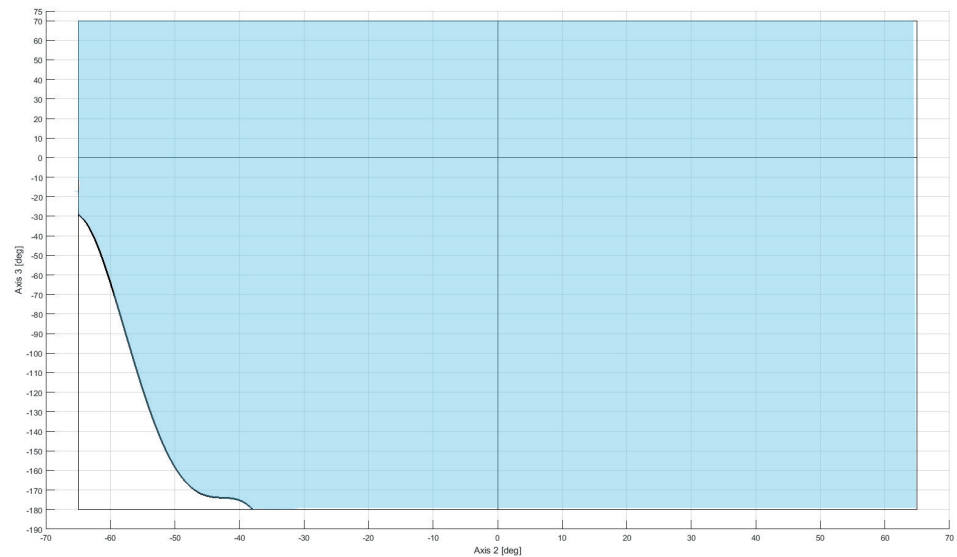

xx170000510

Continues on next page

1 Description

1.8.1 Robot motion

Continued

Working range axis 5 and axis 6 for LeanID, option 780-4

Allowed working area for axis 6 related to axis 5 position is shown in the figure below.

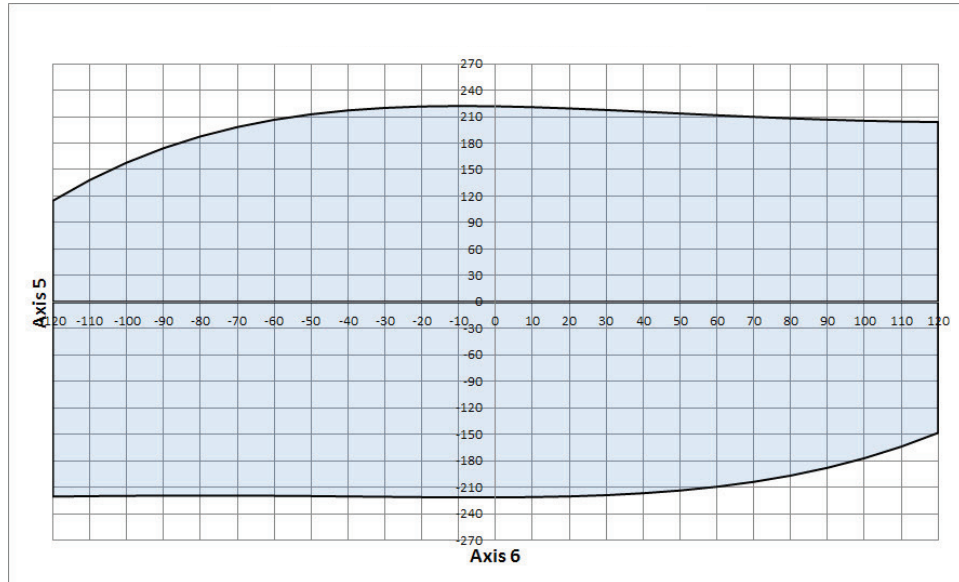

xx1300001587

Continues on next page

1 Description

1.8.1 Robot motion *Continued*

Working range

Robot type	Handling capacity (kg)	Reach (m)
IRB 6700	235	2.65

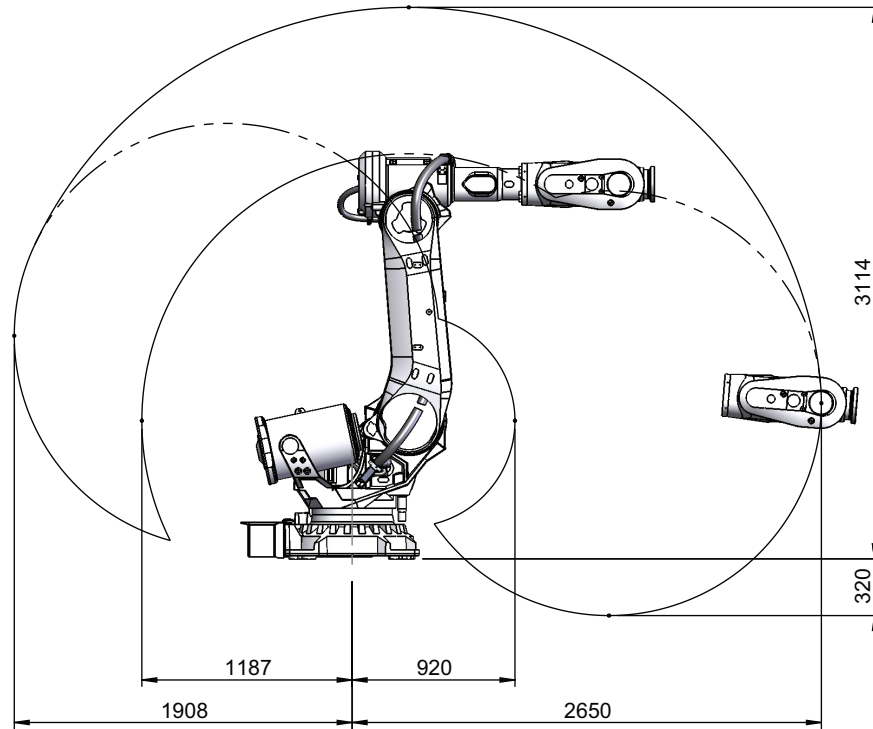

xx130000281

Continues on next page

1 Description

1.8.1 Robot motion

Continued

Robot type	Handling capacity (kg)	Reach (m)
IRB 6700	205	2.80

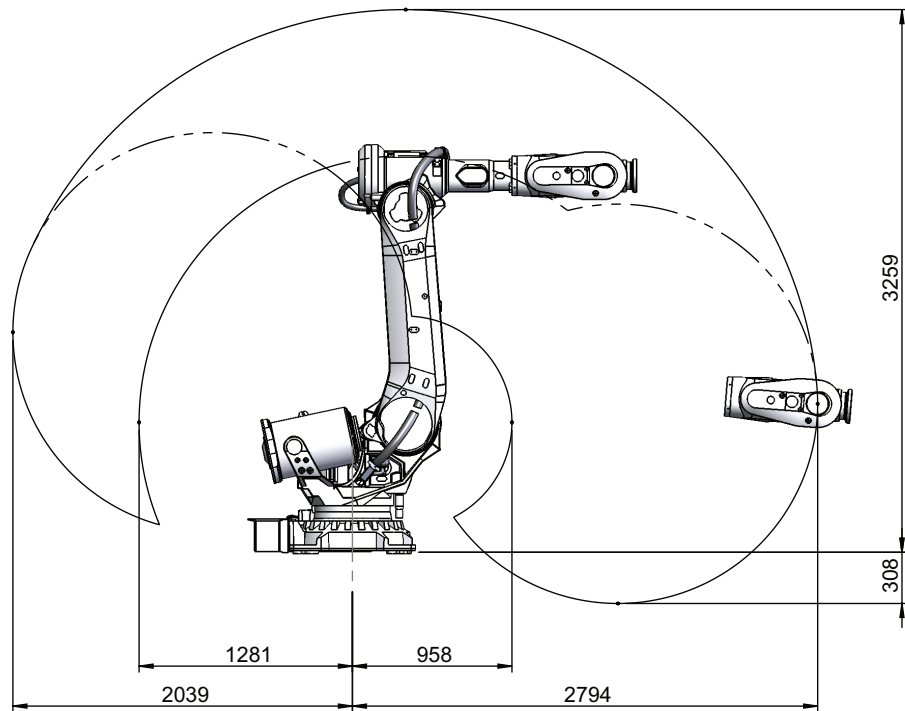

xx1300000282

Continues on next page

1 Description

1.8.1 Robot motion *Continued*

Robot type	Handling capacity (kg)	Reach (m)
IRB 6700	200	2.60

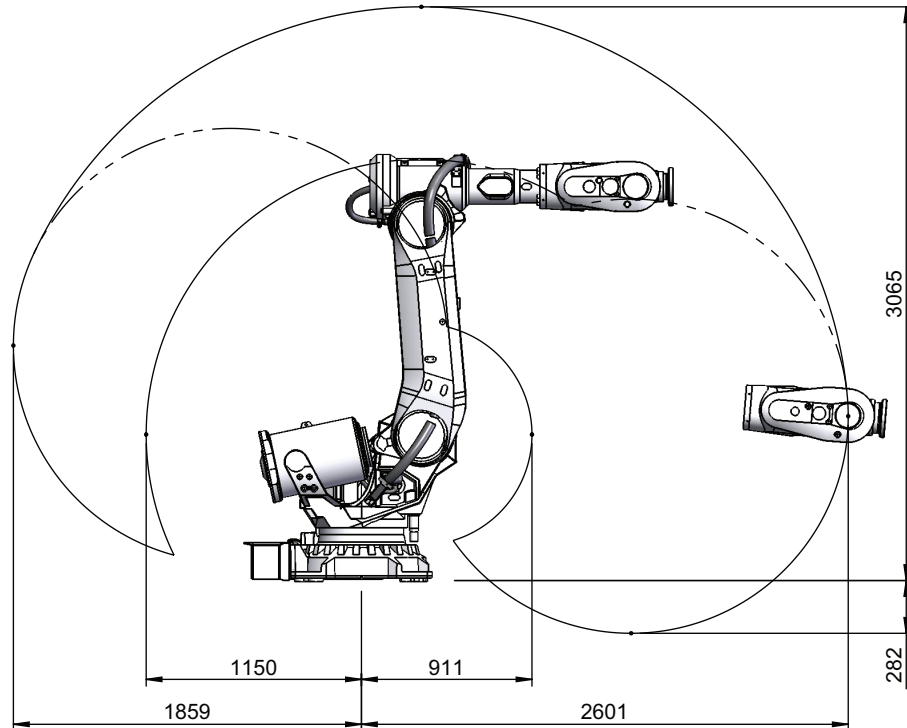

Continues on next page

1 Description

1.8.1 Robot motion

Continued

Robot type	Handling capacity (kg)	Reach (m)
IRB 6700	175	3.05

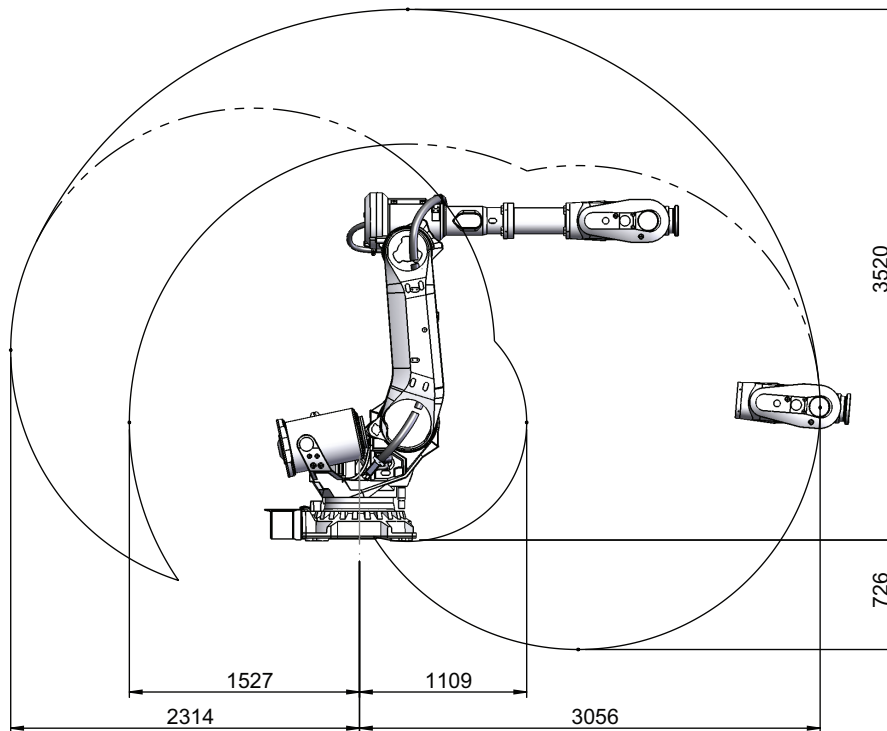

xx1300000283

Continues on next page

1 Description

1.8.1 Robot motion *Continued*

Robot type	Handling capacity (kg)	Reach (m)
IRB 6700	155	2.85

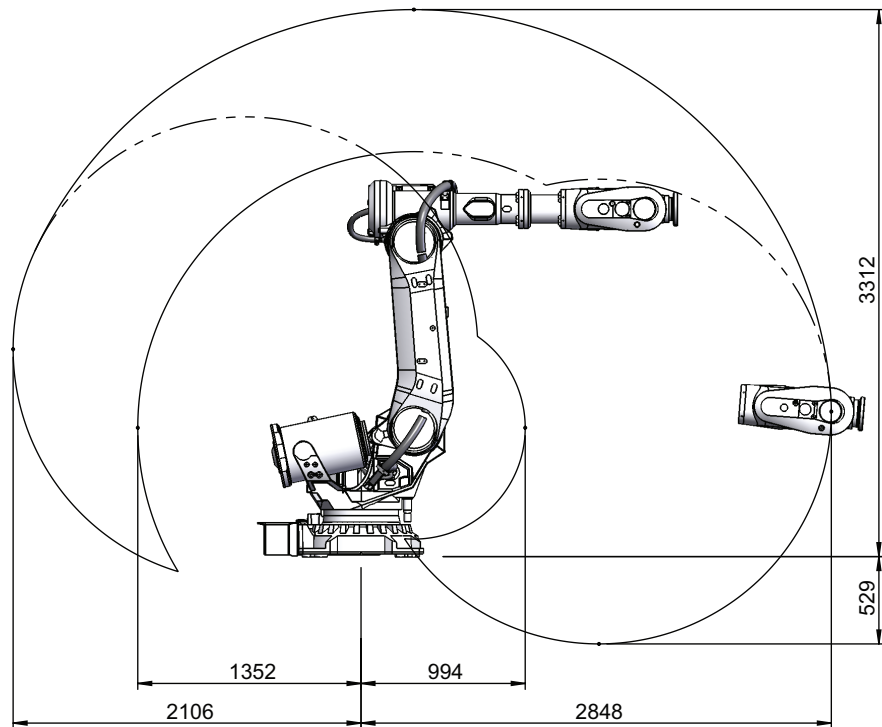

xx130000340

Continues on next page

1 Description

1.8.1 Robot motion

Continued

Robot type	Handling capacity (kg)	Reach (m)
IRB 6700	150	3.20

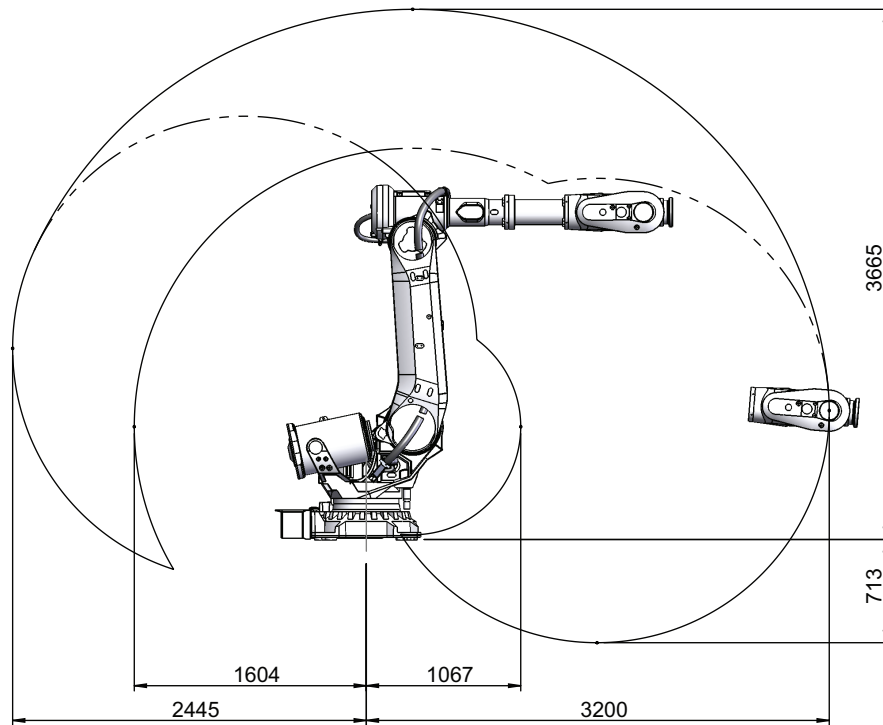

xx1300000284

Continues on next page

1 Description

1.8.1 Robot motion *Continued*

Robot type	Handling capacity (kg)	Reach (m)
IRB 6700	300	2.70

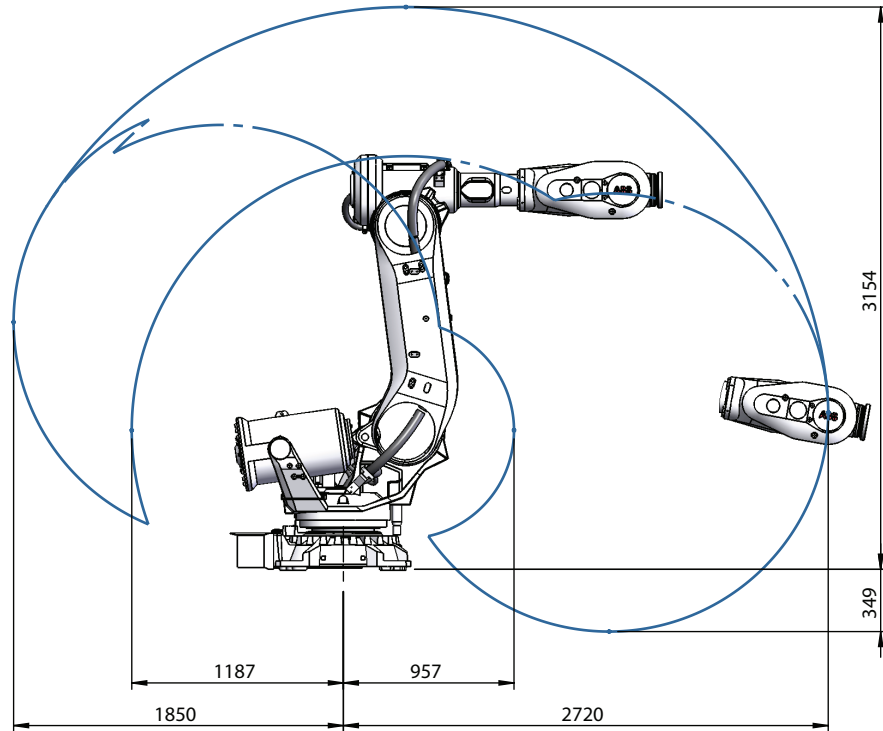

xx1400001137

Continues on next page

1 Description

1.8.1 Robot motion

Continued

Robot type	Handling capacity (kg)	Reach (m)
IRB 6700	245	3.00

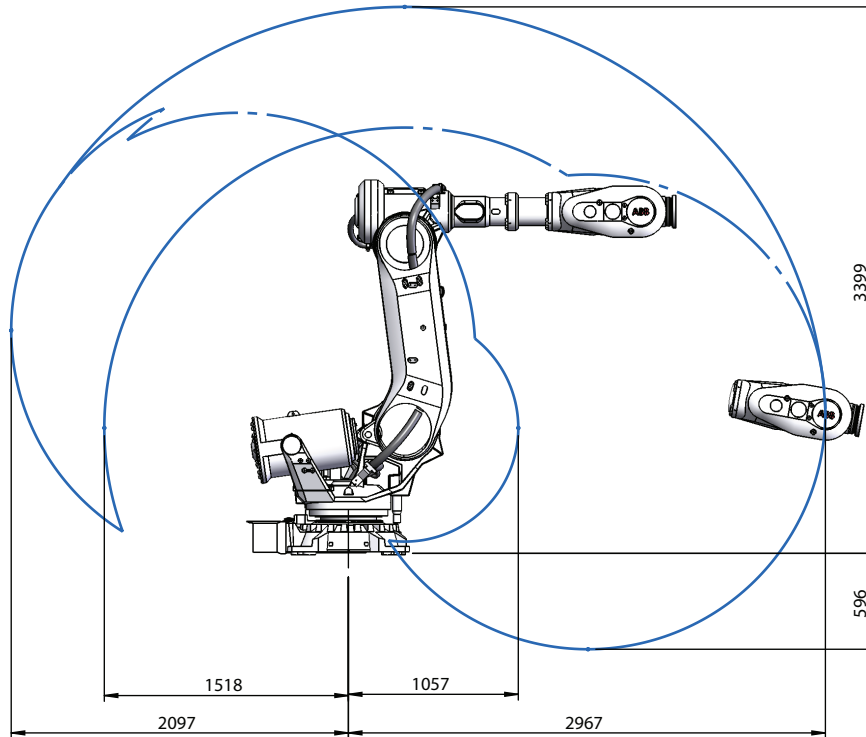

Continues on next page

1 Description

1.8.1 Robot motion

Continued

Robot type	Handling capacity (kg)	Reach (m)
IRB 6700Inv	300	2.60

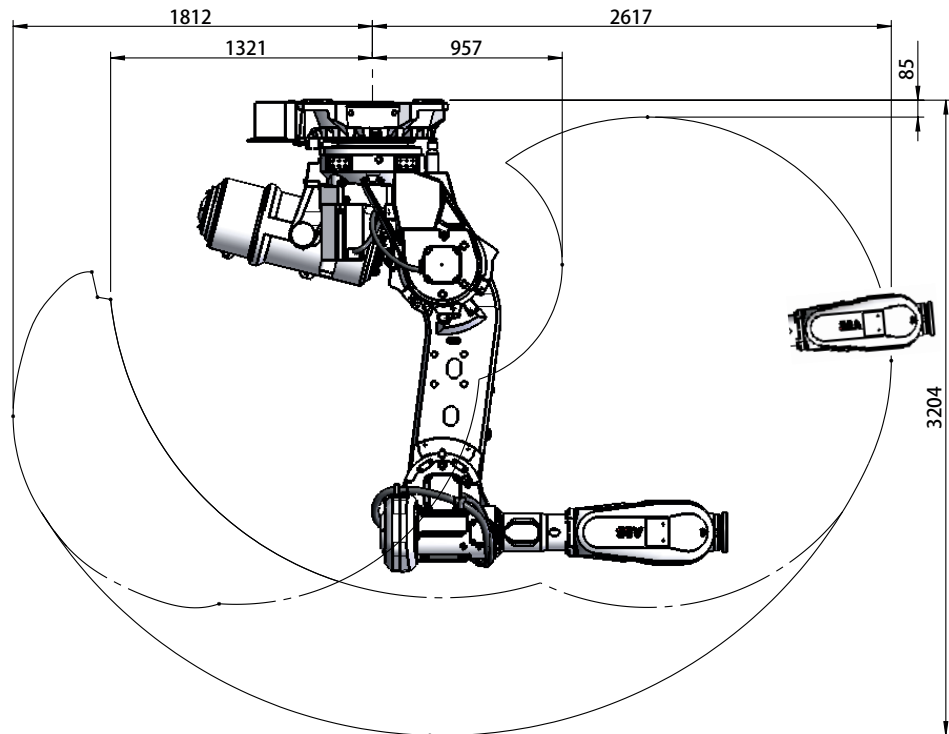

xx170000557

Continues on next page

1 Description

1.8.1 Robot motion

Continued

Robot type	Handling capacity (kg)	Reach (m)
IRB 6700Inv	245	2.90

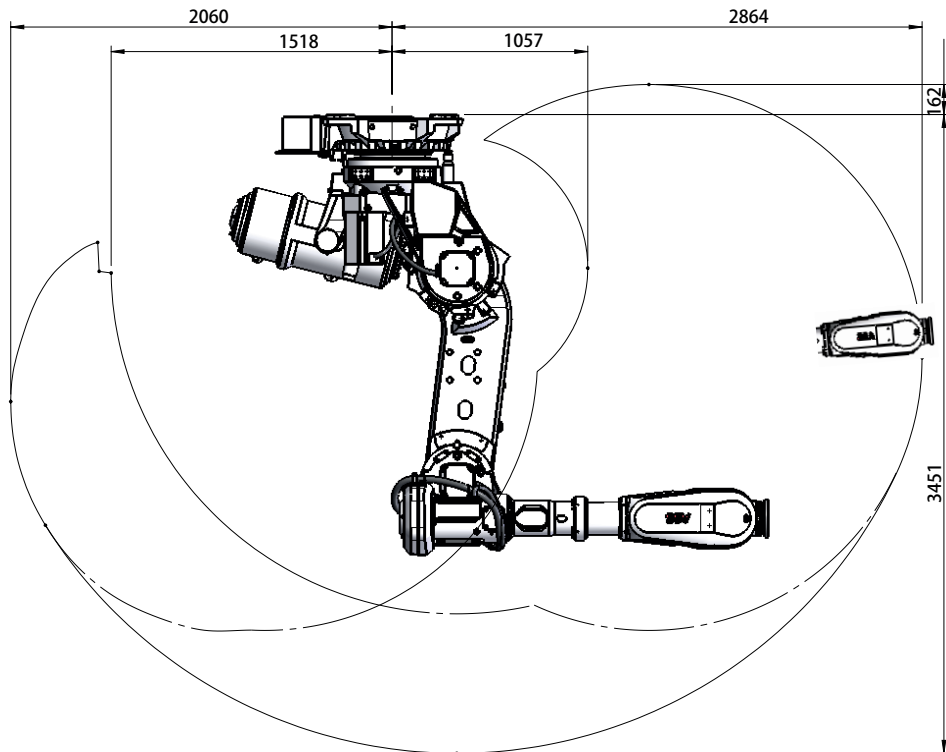

xx1700000558

1.8.2 Performance according to ISO 9283

General

At rated maximum load, maximum offset and 1.6 m/s velocity on the inclined ISO test plane, with all six axes in motion. Values in the table below are the average result of measurements on a small number of robots. The result may differ depending on where in the working range the robot is positioning, velocity, arm configuration, from which direction the position is approached, the load direction of the arm system. Backlashes in gearboxes also affect the result.

The figures for AP, RP, AT and RT are measured according to figure below.

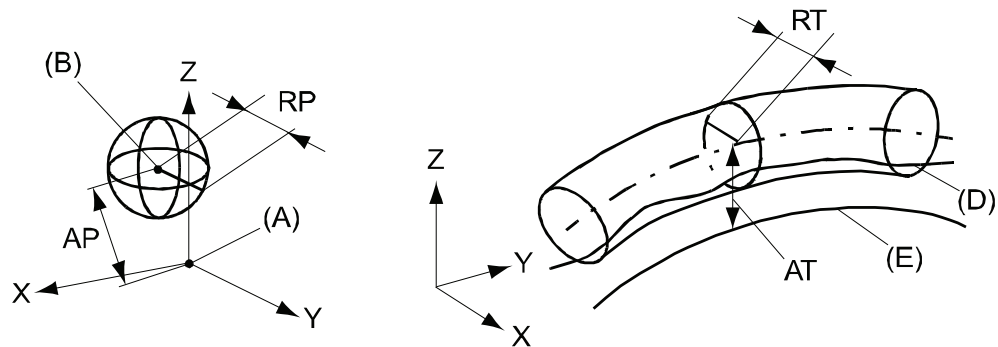

xx080000424

Pos	Description	Pos	Description
A	Programmed position	E	Programmed path
B	Mean position at program execution	D	Actual path at program execution
AP	Mean distance from programmed position	AT	Max deviation from E to average path
RP	Tolerance of position B at repeated positioning	RT	Tolerance of the path at repeated program execution

IRB 6700	235/2.65	205/2.80	175/3.05	150/3.20
Pose accuracy, AP ⁱ (mm)	0.03	0.06	0.04	0.05
Pose repeatability, RP (mm)	0.05	0.05	0.05	0.06
Pose stabilization time, PSt (s) within 0.4 mm of the position	0.16	0.17	0.28	0.34
Path accuracy, AT (mm)	1.7	1.5	1.9	1.6
Path repeatability, RT (mm)	0.08	0.08	0.12	0.14

ⁱ AP according to the ISO test above, is the difference between the taught position (position manually modified in the cell) and the average position obtained during program execution.

Continues on next page

1 Description

1.8.2 Performance according to ISO 9283

Continued

IRB 6700	200/2.60	155/2.85	300/2.70	245/3.00
Pose accuracy, AP ⁱ (mm)	0.03	0.03	0.07	0.03
Pose repeatability, RP (mm)	0.05	0.08	0.06	0.05
Pose stabilization time, PSt (s) within 0.4 mm of the position	0.21	0.19	0.11	0.14
Path accuracy, AT (mm)	1.7	1.5	1.4	1.6
Path repeatability, RT (mm)	0.11	0.09	0.07	0.12

ⁱ AP according to the ISO test above, is the difference between the taught position (position manually modified in the cell) and the average position obtained during program execution.

IRB 6700Inv	300/2.60	245/2.90
Pose accuracy, AP ⁱ (mm)	0.06	0.06
Pose repeatability, RP (mm)	0.05	0.06
Pose stabilization time, PSt (s) within 0.4 mm of the position	0.26	0.28
Path accuracy, AT (mm)	1.6	1.6
Path repeatability, RT (mm)	0.1	0.22

ⁱ AP according to the ISO test above, is the difference between the taught position (position manually modified in the cell) and the average position obtained during program execution.

1.8.3 Velocity

Maximum axis speed

Robot type	Axis 1	Axis 2	Axis 3	Axis 4	Axis 5	Axis 6
IRB 6700-235/2.65	100 °/s	90 °/s	90 °/s	170 °/s	120 °/s	190 °/s
IRB 6700-205/2.80	100 °/s	90 °/s	90 °/s	170 °/s	120 °/s	190 °/s
IRB 6700-200/2.60	110 °/s	110 °/s	110 °/s	190 °/s	150 °/s	210 °/s
IRB 6700-175/3.05	100 °/s	90 °/s	90 °/s	170 °/s	120 °/s	190 °/s
IRB 6700-155/2.85	110 °/s	110 °/s	110 °/s	190 °/s	150 °/s	210 °/s
IRB 6700-150/3.20	100 °/s	90 °/s	90 °/s	170 °/s	120 °/s	190 °/s
IRB 6700-300/2.70	100 °/s	88 °/s	90 °/s	140 °/s	110 °/s	180 °/s
IRB 6700-245/3.00	100 °/s	88 °/s	90 °/s	140 °/s	110 °/s	180 °/s
IRB 6700Inv-300/2.60	100 °/s	88 °/s	90 °/s	140 °/s	110 °/s	180 °/s
IRB 6700Inv-245/2.90	100 °/s	88 °/s	90 °/s	140 °/s	110 °/s	180 °/s

There is a supervision function to prevent overheating in applications with intensive and frequent movements (high duty cycle).

1 Description

1.8.4 Robot stopping distances and times

1.8.4 Robot stopping distances and times

Introduction

The stopping distances and times for category 0 and category 1 stops, as required by EN ISO 10218-1 Annex B, are listed in *Product specification - Robot stopping distances according to ISO 10218-1 (3HAC048645-001)*.

1.9 Cooling fan for axis 1 motor

Option 87-1

To be used to avoid overheating of motors and gears in applications with intensive motion (high average speed and /or high average torque and/or short wait time) of axis 1.

Valid protection for cooling fan is IP54. Fan failure stops the robot. The option is not allowed to select when the robot is placed on a track motion, IRBT.

To determine the use of cooling fan for axis 1 motor use the function **Gearbox Heat Prediction Tool** in RobotStudio. Reliable facts for the decision of need for fan or not will be achieved by entering the ambient temperature for a specific cycle. Contact your local ABB organization.

1 Description

1.10.1 Introduction

1.10 Servo gun

1.10.1 Introduction

General

The robot can be supplied with hardware and software for control of the following configurations:

- Stationary Gun
- Robot Gun
- Robot Gun and Track Motion
- Track Motion

The specific parts related to the servo motor control for electrical welding guns and for track motion configurations are shown in the conceptual pictures below. The major parts and required options are also stated in the configurations lists below each picture.

The cables for control of the basic robot are shown in the pictures with dotted lines.

1.10.2 Stationary gun

General

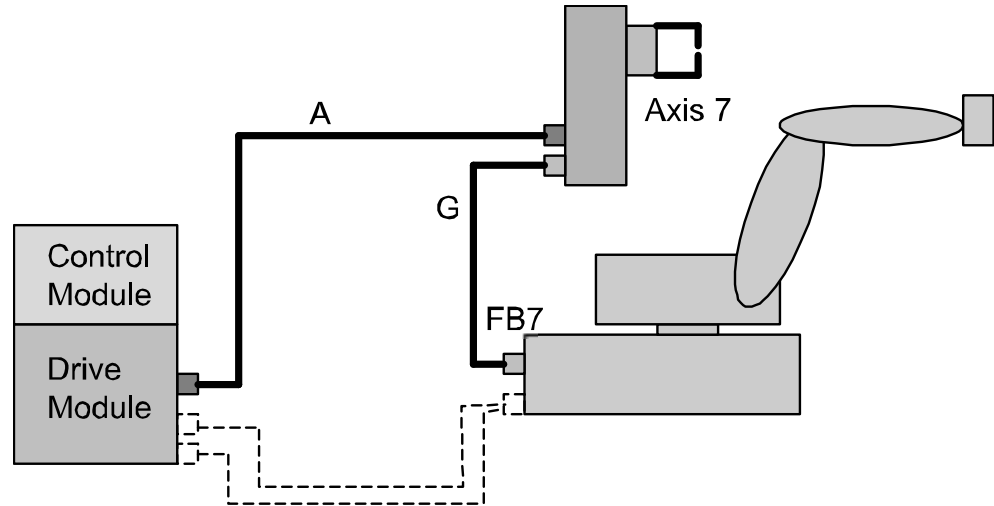

xx1000000507

Options

Options according to the table below are required to complete the delivery. For further details on each option see corresponding product specification.

Option	Description	Product specification
785-5	Stationary gun. This option includes cable G (7 m length) for resolver signals from robot base (FB7) to stationary gun/axis 7.	
864-1	Resolver connection, axis 7, on base.	
907-1	First additional drive. Drive unit for 7th axis with corresponding cables assembled inside drive module.	<i>Product specification - Controller IRC5</i>
786-1, -2, -3, -4	Connection to first drive. Cable A (7-30 m) between drive module and stationary gun/axis 7 for servo drive power.	
635-6	Spot 6. This option includes Spot Servo and Spot Servo Equalizing.	<i>Product specification - Controller IRC5</i>

1 Description

1.10.3 Robot gun

1.10.3 Robot gun

General

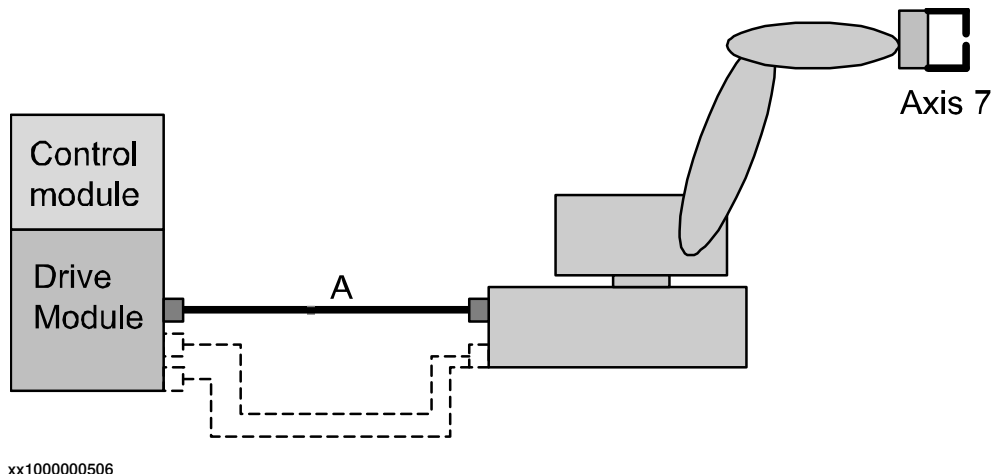

Option

Options according to table below are required to complete the delivery. For further details on each option see corresponding product specification.

Option	Description	Product specification
785-1	Robot gun. This option includes cables within manipulator for servo power signals (servo gun/axis 7).	
907-1	First additional drive. Drive unit for 7th axis with corresponding cables assembled inside drive module.	<i>Product specification - Controller IRC5</i>
786-1, -2, -3, -4	Connection to first drive. Cable A (7-30 m) between drive module and robot base for servo drive power.	
635-6	Spot 6, Spot Servo, or Spot Servo Equalizing.	<i>Product specification - Controller IRC5</i>

1.10.4 Robot gun and track motion

General

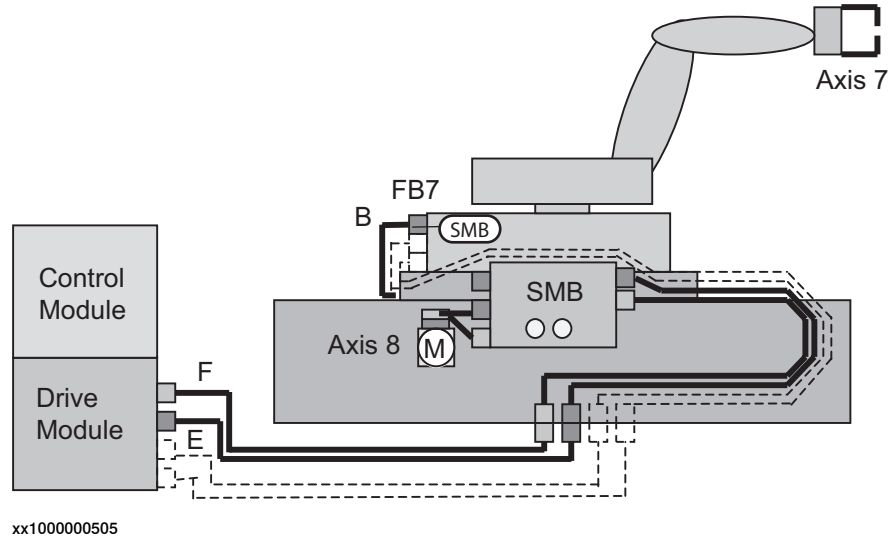

Options

Options according to table below are required to complete the delivery. For further details on each option see corresponding product specification.

Option	Description	Product specification
785-1 +1002-2 ⁱ	Robot Gun - Track Motion. This option includes cables within manipulator for servo power signals (servo gun/axis 7).	<i>Product specification - IRBT 4004/6004/7004</i>
Track motion delivery includes	Serial measurement box (SMB2, Split box) for distribution of servo power to axis 8. The box is placed on the track motion. Cables from serial measurement box to track motion. Cable B for servo power (1.5 m length). Connection to first and second drive. Cable E and F (7-22 m) between drive module and serial measurement box for dual servo drive power/resolver signals.	<i>Product specification - IRBT 4004/6004/7004</i>
907-1	First additional drive. Drive unit for 7th axis with corresponding cables assembled inside drive module.	<i>Product specification - Controller IRC5</i>
907-1	Second additional drive. Drive unit for 8th axis with corresponding cables assembled inside drive module.	<i>Product specification - Controller IRC5</i>
635-6	Spot 6, Spot Servo, or Spot Servo Equalizing.	<i>Product specification - Controller software IRC5</i>
864-1	Resolver connection, axis 7, on base (FB7).	

ⁱ To specify robot on track equipped with servo gun. Option 1002-2 from specification form for track motion.

1 Description

1.10.5 Track motion

1.10.5 Track motion

General

The robot can be supplied with a track motion, see *Product specification - IRBT 4004/6004/7004*. For configuration and specification of hardware see the following figure.

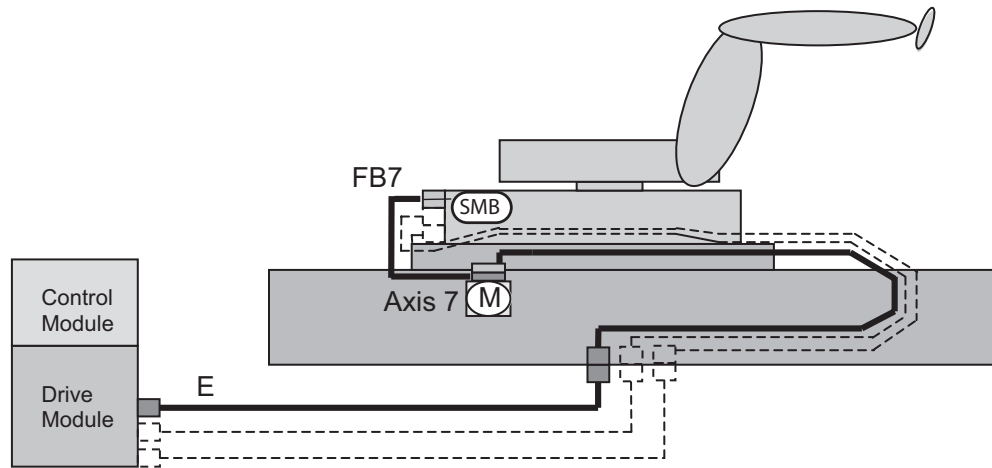

xx100000504

Options

Options according to table below are required to complete the delivery. For further details on each option see corresponding product specification.

Option	Description	Product specification
Track motion delivery includes	Serial measurement (SMB) in manipulator is used, together with option 864-1, FB7 for signals to axis 7/Track motion. Cable E for between Drive Module and track motion servo for drive power.	<i>Product specification - IRBT 4004/6004/7004</i>
907-1	First additional drive. Drive unit for 7th axis with corresponding cables assembled inside drive module.	
864-1	Resolver connection, axis 7, on base (FB7).	

2 DressPack

2.1 Introduction

2.1.1 Included options

DressPack

Includes options for upper arm, lower arm and floor pos B, C and D, see the following figure. These are described separately below but are designed as a complete package for various applications.

The DressPack for the floor contains customer signals.

The DressPack for upper and lower arm contains process cable packages including signals, for customer use.

Necessary supports and brackets are also included.

The routing of the process cable package on the robot is available in different configurations.



Note

Include everywhere that this is also for IRB 6700Inv (e.g. "This is available for all IRB 6700 and IRB 6700Inv versions").

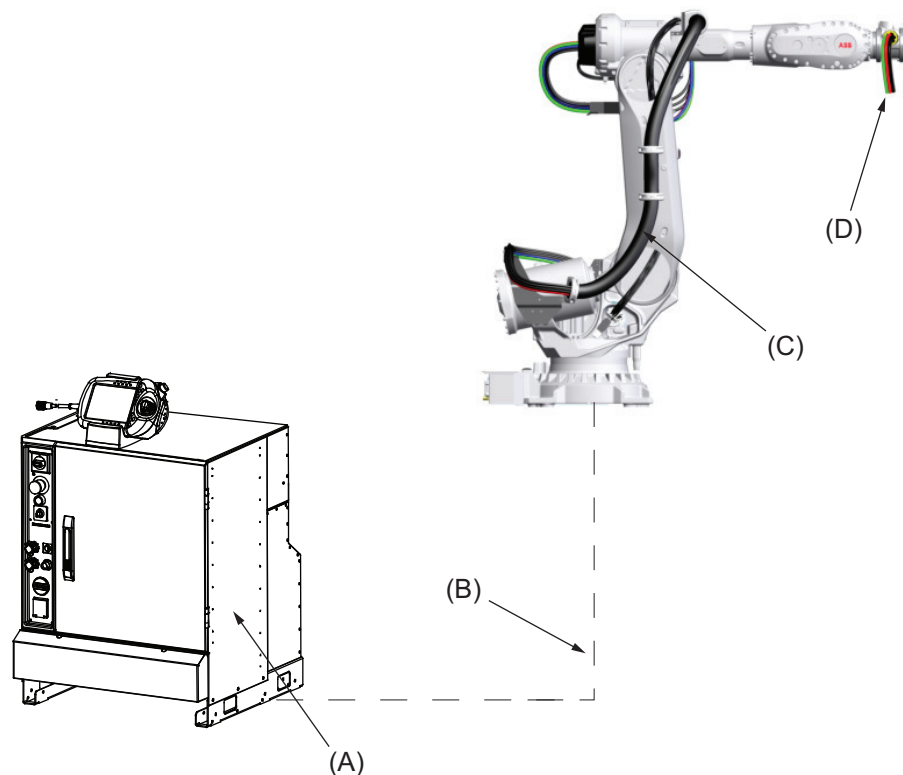

xx1300001588

Continues on next page

2 DressPack

2.1.1 Included options

Continued

Pos	Description
A	Robot controller, (including 7th axis drive for servo gun)
B	DressPack, floor
C	DressPack, lower arm
D	DressPack, upper arm

Continues on next page

Spotwelding

The package supplies above described DressPack, transformer gun/gripper with necessary media and software, see the following figure.

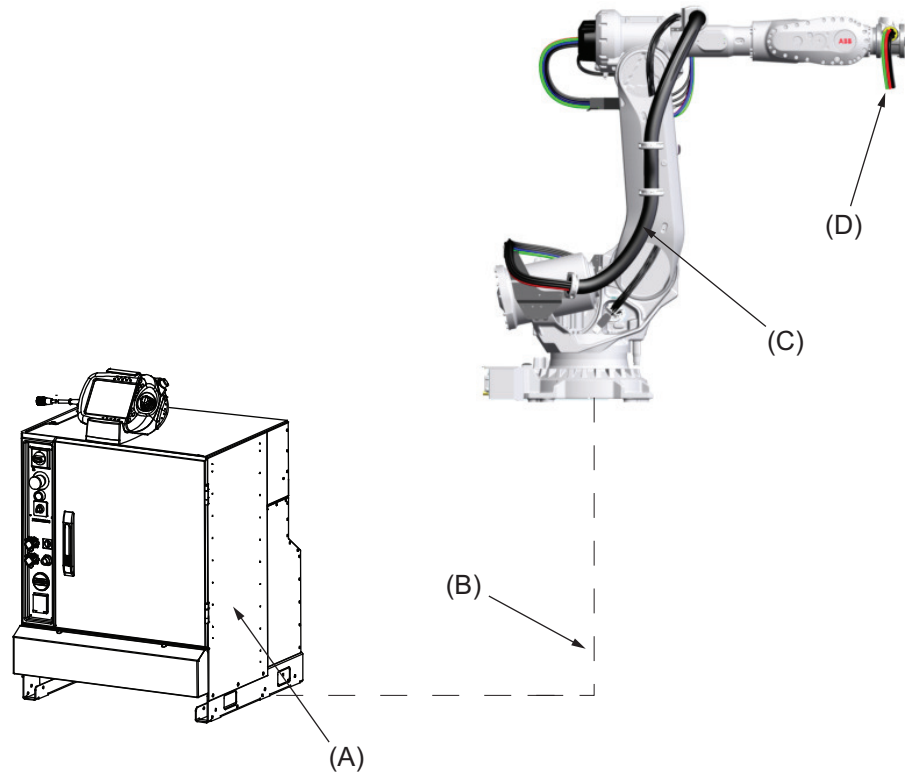

xx1300001588

Pos	Description
A	Robot controller, (including 7th axis drive for servo gun)
B	DressPack, floor
C	DressPack, lower arm
D	DressPack, upper arm

2 DressPack

2.1.2 Product range

2.1.2 Product range

DressPack solutions for different users needs

The different robot types can be equipped with the well integrated cable and hose packages in the DressPack options. The DressPack is designed in close conjunction with the development of the manipulator and is therefore well synchronized with the robot.

As there is a big span between different users need of flexibility, depending of the complexity of the operation/wrist movements, there are two major levels of dress pack solutions available, see Figure below.

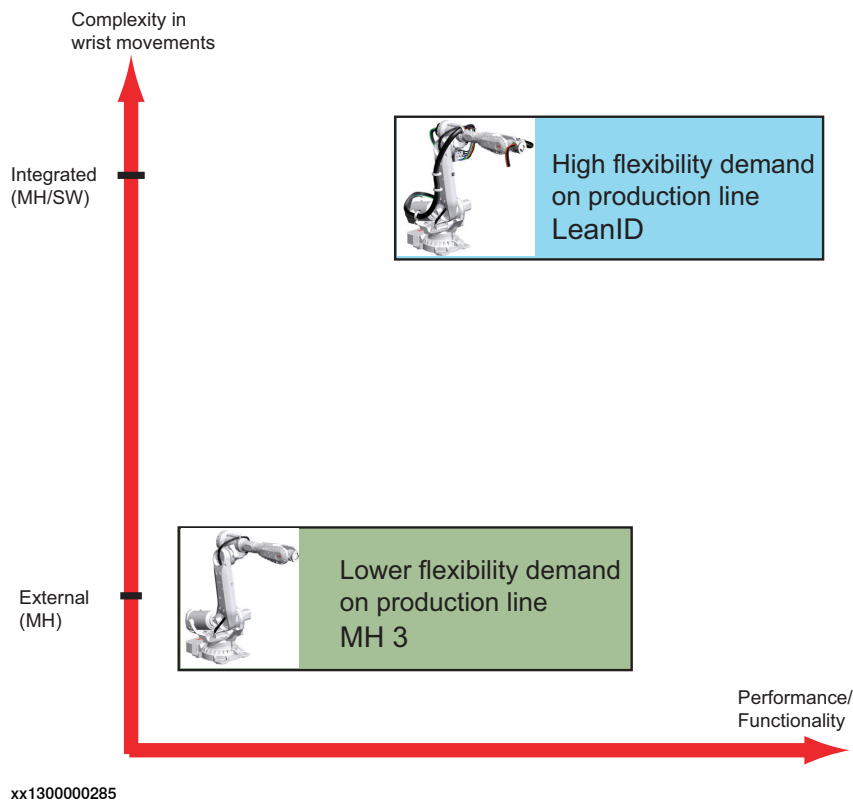

Integrated

This type of dress pack is intended for a production where there are many complex wrist movements and the need for flexibility in changing products is high.

Available options are 798-3 and 780-4 for material handling/spot welding, the LeanID concept.

External

This type of dress pack is recommended where there are less complexity in wrist movements. This normally occurs when there are not many different products running in the production cell. This package requires more individual adjustment to optimize towards robot program at set up.

Available options are 798-3 and 780-3 for material handling.

2.1.3 Limitations of robot movements

General

When using DressPack options on the upper arm the robot movements will be limited.

- In bending backwards positions there are limitations due to interference with manipulator.
- Might restrict working range, see [Working range axis 5 and axis 6 for LeanID, option 780-4 on page 84](#).



Note

For more detail information please contact Serop Product support/SEROP/ABB.
E-mail address: serop.product_support@se.abb.com

Restrictions for LeanID, option 780-4

Limitation for axis 5 and 6 depends on how the dress pack is assembled at the tool and how adjustment has been done.

Axis	Working range
Axis 5	120° to -120°
Axis 6	220° to -220°

2 DressPack

2.1.4 Impact on MH3 DressPack lifetime

2.1.4 Impact on MH3 DressPack lifetime

General

There are some robot movements/positions that shall be avoided in the robot production program. This will improve the lifetime significantly of external upper arm MH3 DressPack and wear parts e.g. protection hose, hose reinforcement and protective sleeves.

- The axis 5 movement is not allowed to press the DressPack against the robot upper arm.
- Combined rotation of the wrist axes must be limited so that the DressPack is not wrapped hard against the upper arm.

See the Product Manual for more detailed information and recommended set-up adjustments.

2.1.5 Information structure

General

The information for DressPack is structured in the following way.

The DressPack can be delivered in two versions developed for two different applications. Each type is described in a separate section.

Section	Option	Description
2.2	DressPack	DressPack includes general description DressPack with common information.

Material handling application DressPack

Section	Option	Description
2.3	Type H	DressPack for Material Handling.
	Type Hse	DressPack for handling the part against electrical servo driven transformer guns stationary mounted.

Spot welding application DressPack

Section	Option	Description
2.4	Type Se	DressPack for electrical servo driven transformer guns carried by the robot manipulator.

Connector kits

Section	Option	Description
2.3	Connector Kits	Includes general description of connector kits for Spot-Pack and DressPack.

2 DressPack

2.2.1 Introduction

2.2 DressPack

2.2.1 Introduction

Available DressPack configurations for Material Handling

The table below shows the different DressPack configurations available for Material Handling.

	Lower arm	Upper arm
Option 778-1, Material Handling	Option 798-3, Base to axis 3 Internal routing in lower arm	Option 780-3, Axis 3 to 6 External routing
		Option 780-4, Axis 3 to axis 6 (LeanID) Internal routing

Available DressPack configurations for Spot Welding

The table below shows the different DressPack configurations available for Spot Welding.

	Lower arm	Upper arm
Option 778-2, Spot Welding	Option 798-3, Base to axis 3 External routing	Option 780-4, Axis 3 to axis 6 (LeanID) Internal routing

Lower arm

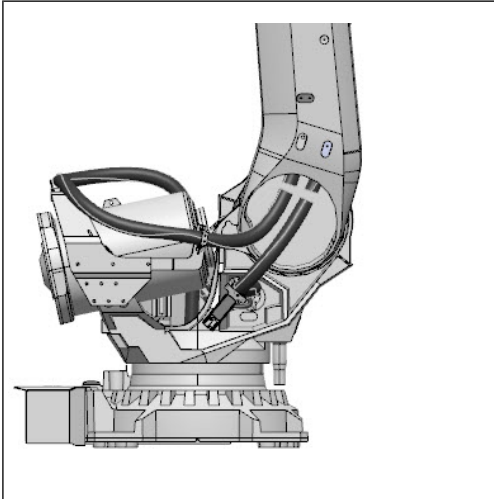
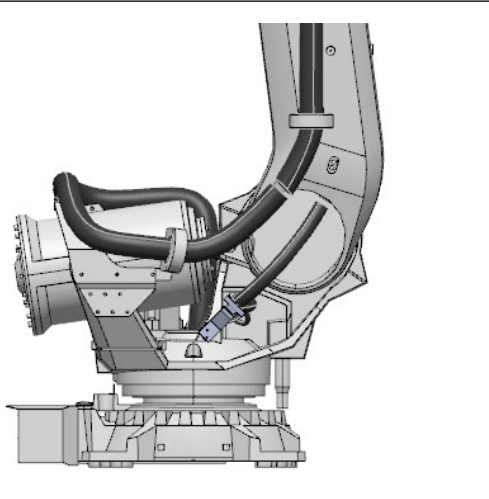
	
Internal routing in lower arm Option 778-1 (Material handling) Option 798-3, Base to axis 3 Option 3325-11/12/13, Base to axis 3	External routing Option 798-3, Base to axis 3 Option 3325-11/12/13, Base to axis 3

2.2.2 Built-in features for upper arm DressPack

External

Material handling (option 780-3):

- Internal routing through the rear part of the upper arm.
- Protection hose can easily be replaced if damaged.
- One version for all IRB 6700 versions and all IRB 6700Inv versions.
- Adjustment for optimal hose/cable lengths.

Internal

Spot Welding and Material handling (option 780-4):

- Partly internal routing through the upper arm.
- Suitable for complex movements.
- High demands for flexibility and accessibility.
- Longer lifetime.
- Predictable movements.
- Easy exchange of DressPack.

2 DressPack

2.2.3 Interface descriptions for DressPack

2.2.3 Interface descriptions for DressPack

General

Below is an overview showing the different DressPack options connection points, and their locations. For detailed information see the circuit diagram, and *Product manual - DressPack/SpotPack IRB 6700*.

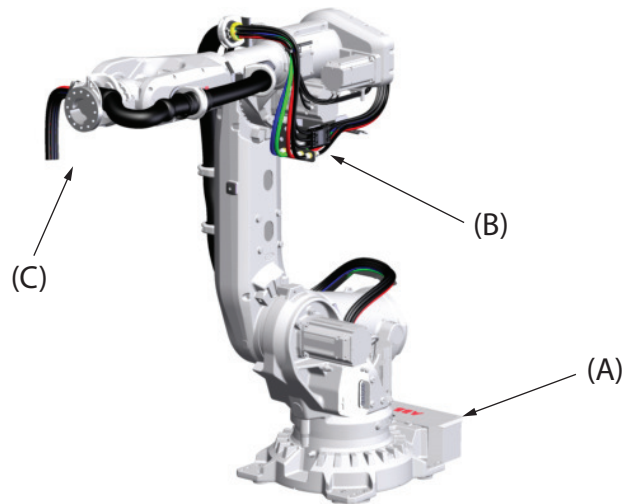

xx1300000224

Pos	Location	Description	Options
A	Base	FB7, CP/CS/CBUS	864-1, 798-3
B	Axis 3	CP/CS/CBUS	798-3
C	Axis 6	CP/CS/CBUS, WELD	780-3, 780-4

Continues on next page

Base

Material handling (option 798-3), see figure below:

, see figure below:

- Included are: A, one D (Proc 1).

, see figure below:

- Included are: A, E, F and one D.

Spot welding (option 798-3), see figure below:

- Included are: A, B (if applicable), C, D (Proc 1-4) and E, F (if applicable).

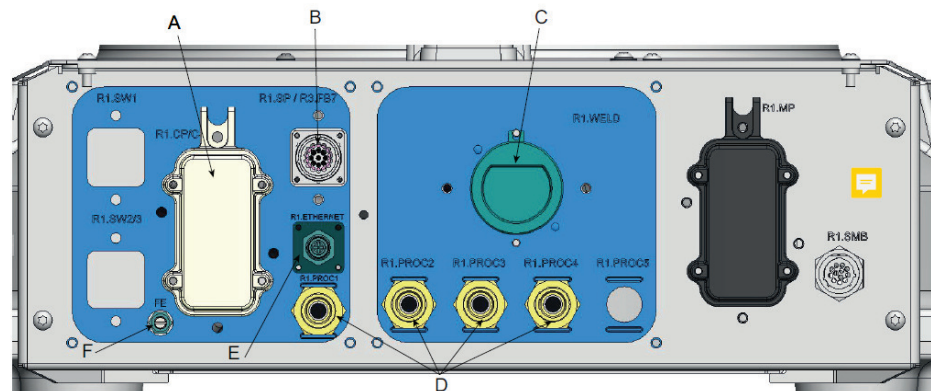

xx1900001501

For corresponding parts of the tool, see [Connection kits on page 143](#).

Pos	Description
A	R1.CP/CS
B	R1.SP (Spot Welding Servo gun) or FB7 (Resolver connection)
C	R1.WELD 3x35mm ² . (Spot Welding)
D	R1.PROC 1 (Material Handling/Spot Welding 1/2", M22x1.5, 24 degree seal) R1.PROC 2 - 4 (Spot Welding 1/2", M22x1.5, 24 degree seal)
E	R1.ETHERNET (M12 connector, when EtherNet communication is selected)
F	FE (Functional Earth, when EtherNet communication is selected)

Continues on next page

2 DressPack

2.2.3 Interface descriptions for DressPack

Continued

Axis 3

Material Handling (option 798-3), see figure below:

, see figure below:

- Included are: A and one C (Proc 1).

, see figure below:

- Included are: A, G and one C (Proc 1).

, see figure below:

- Included are: A, G, B, H and one C (Proc 1).

Spot welding (option 798-3), see figure below:

- Included are: A, D, B/E/F/G/H (if applicable) and C (Proc 1-4).

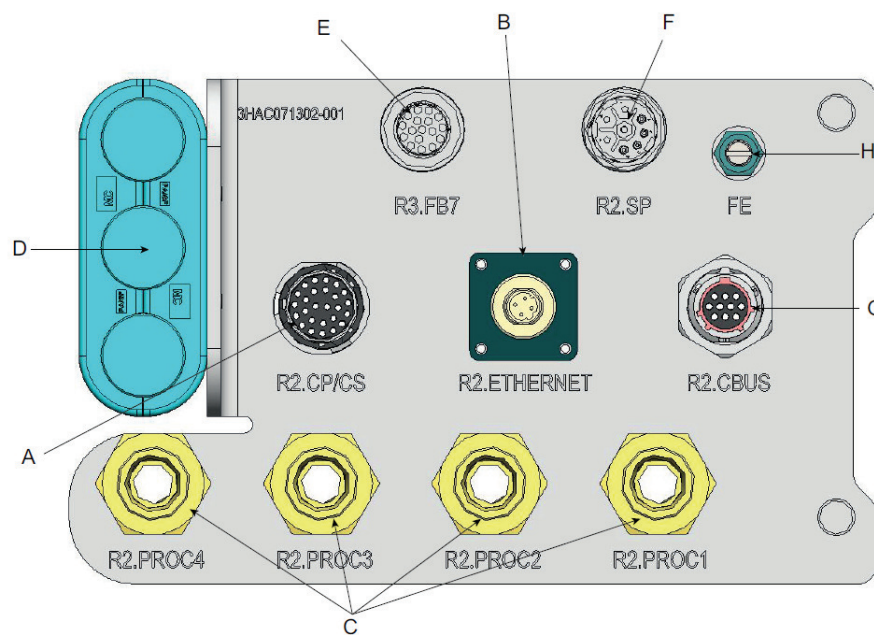

xx1900001511

For corresponding parts of the tool, see [Connection kits on page 143](#).

Pos	Description
A	R2.CP/CS
B	R2.ETHERNET (M12 connector, when EtherNet communication is selected)
C	R2.PROC 1 (Material Handling 1/2", M22x1.5, 24 degree seal) R2.PROC 2-4 (Spot Welding 1/2", M22x1.5, 24 degree seal)
D	R2.WELD 3x35mm ² (Spot Welding)
E	R2.FB7
F	R2.SP (Spot Welding Servo gun)
G	R2.CBUS (UTOW connector when Profibus or DeviceNet communication is selected)
H	FE (Functional Earth, when EtherNet communication is selected)

Continues on next page

Axis 6**External**

Material handling (option 780-3), see figure below:

, see figure below:

- Hose and cable free length, min. 1000 mm.
- Air hose ends with free end.

The cable ends with a connector, the main parts are described in the list below (for corresponding parts of the tool, see [Connection kits on page 143](#)):

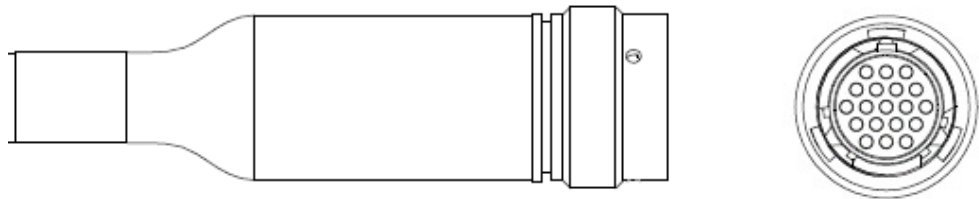

xx0900000728

Material handling connector

Material handling (option 780-3), see figure below:

, see figure below:

- Cable free length, min. 1000 mm.
- Signals are connected with a M12 connector.

The different main parts within the connector are described in the list below, both with name and Harting article number (for corresponding parts of the tool, see within the Harting product offer).

Continues on next page

2 DressPack

2.2.3 Interface descriptions for DressPack

Continued

Material Handling connector (LeanID)

Material Handling/Spot Welding option 780-4 (LeanID), see figure below:

, see figure below:

- Hose and cable free length, min. 1160 mm.
- Hoses and weld power cable (only for spot welding) end with free end.

The cable ends with connectors, for corresponding parts of the tool, see [Connection kits on page 143](#) and within the UTOW product offer.

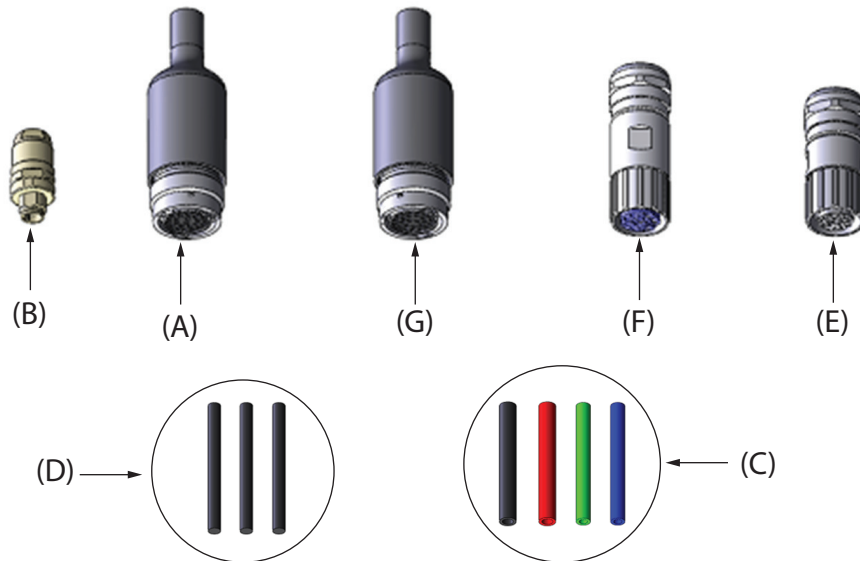

xx120000117

Pos	Description
A	R3.CP/CS (UTOW connector 26p) Customer signals and power
B	R3.ETHERNET (M12 connector) EtherNet signals (when EtherNet communication is selected)
C	R3.PROC 1-2 (1/2", freeend) R3.PROC 2-4 (3/8", free end) Media hoses
D	R3.WELD 3x25mm ² (Free end) Spot Welding power
E	R3.FB7 (M23 connector 17p) Servo motor feedback (when Spot Welding Servo gun is selected)
F	R3.SP (M23 connector 8p) Servo motor power (when Spot Welding Servo gun is selected)
G	R3.CBUS (UTOW connector 10p) BUS signals (when Profibus or DeviceNet communication is selected)

- FE (M8 cable lug) Functional Earth 10mm² (When Parallel and Ethernet communication is selected)

Continues on next page

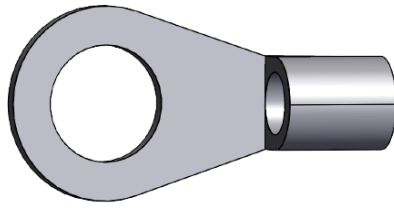

xx2000000109

2 DressPack

2.2.4 Dimensions

2.2.4 Dimensions

Dimensions for robot with DressPack



Note

Dimensions for specific variant can be measured in 3D-Cad models.

Dimensions are shown in figures below.

Axis 3 to axis 6 (option 780-3)

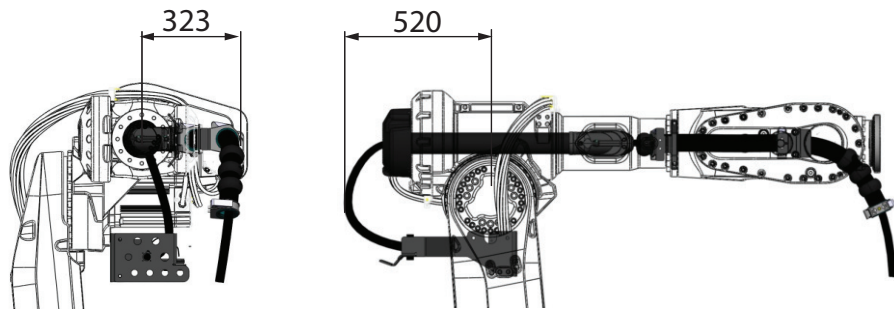

xx1300000286

Option 778-2 (Spot Welding) + Option 798-3 (Base to axis 3) + Option 780-4 (Axis 3 to axis 6)

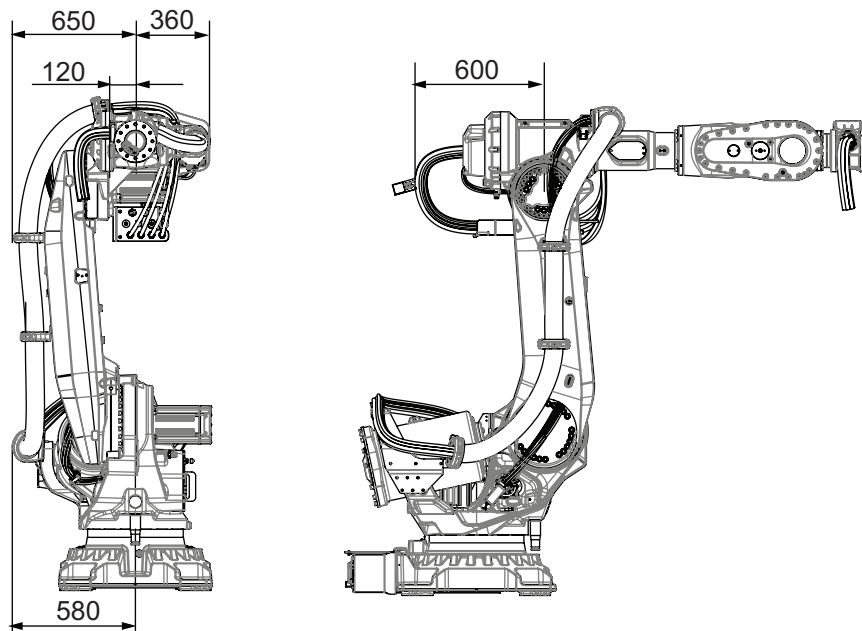

xx1300000287

Base to axis 3 + Axis 3 to axis 6 (option 798-3 + 780-4)

Continues on next page

Option 778-1 (Material handling) + Option 798-3 (Base to axis 3) + Option 780-4 (Axis 3 to axis 6)

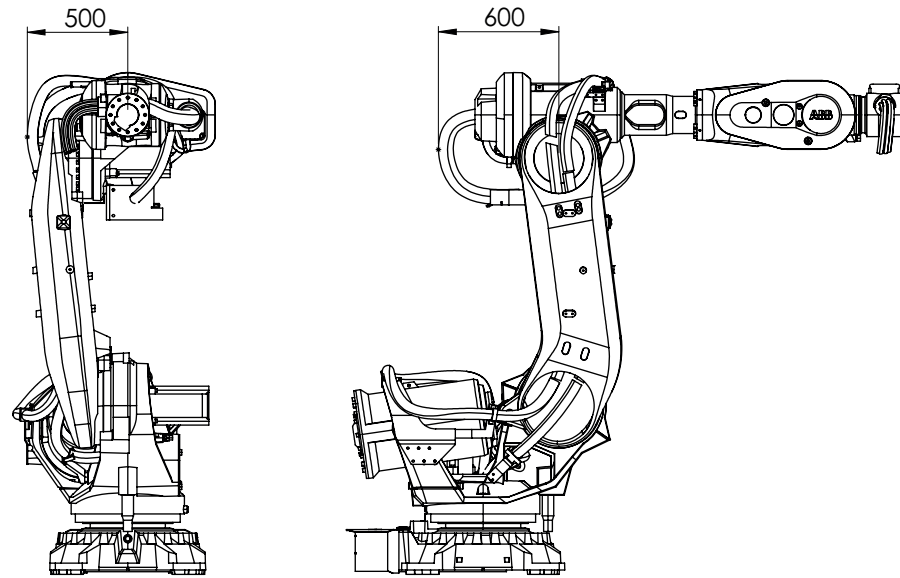

xx2000001776

2 DressPack

2.3.1 Introduction

2.3 Type H/HSe

2.3.1 Introduction

General

Variant Type H is designed for Material Handling (MH) application and Hse to handling parts against a stationary Spot Welding gun (pneumatic or servo controlled). Included modules are shown in Figure below.

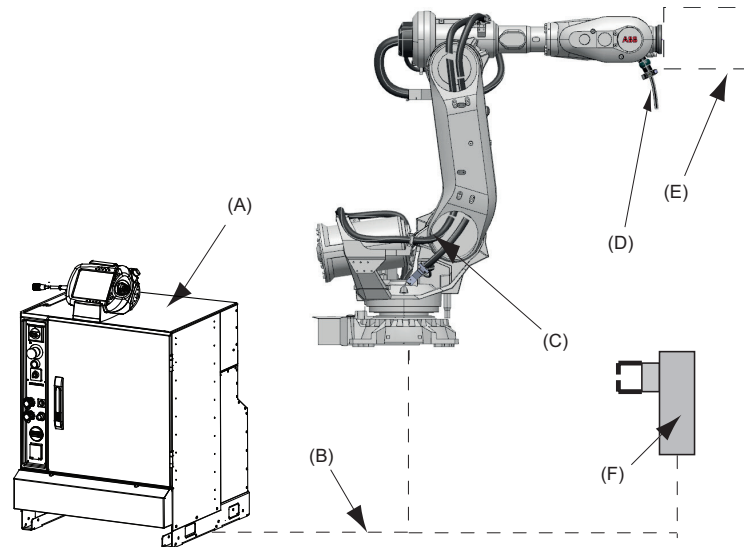

xx2000001777

Pos	Name	
A	Robot Cabinet IRC5	Incl. 7:th axis drive for servo gun, HSe
B	DressPack, Floor	
C	DressPack, Lower arm	
D	DressPack, Upper arm	For type H and HSe
E	Robot Gripper	
F	Stationary gun	Pneumatic or servo controlled and HSe

Available configurations with linked option numbers are described below.

Option description

Option	Type	Description
16-1	Connection to cabinet	<p>Floor cables and connections inside the I/O section for the DressPack are chosen. The length and configuration of the floor harness is specified under the options below.</p> <p>Option 94-X for parallel communication.</p> <p>Option 90-X for parallel communication and field bus communication with Can/DeviceNet.</p> <p>Option 92-X for parallel communication and field bus communication with Profibus.</p>

Continues on next page

Option	Type	Description
455-1	Parallel communication	Offers the signal cables needed for parallel communication in lower and upper arm DressPack. To be combined with option 94-X.
455-4	Parallel and Bus communication	Offers the signal cables needed for the combination of parallel and bus communication in lower and upper arm DressPack. To be combined with option 90-X or 92-X.
455-8	Parallel and Ethernet communication	Offers the signal cables needed for the bus communication in lower and upper arm DressPack. To be combined with option 859-X. Requires selection of option 94-X.

The available alternatives and allowed combinations are shown in the schematic Figures below.

Application Interface connected to Option 16-1, Cabinet	Option 455-1 Parallel communication	Option 94-X Cable length, Parallel communication	Option 778-1 Material Handling
	Option 455-4 Parallel and bus communication	Option 90-X Option 92-X Cable length, Parallel and bus communication	
	Option 455-8 Parallel and Ethernet communication	Option 859-X Cable length, Ethernet communication	

DressPack

	Lower arm	Upper arm
Option 778-1. Material Handling	Option 798-3, Base to axis 3 Internal routing in lower arm	Option 780-3, Axis 3 to 6 External routing
		Option 780-4, Axis 3 to 6 Internal routing

2 DressPack

2.3.2 Configuration result for Type H HSe

2.3.2 Configuration result for Type H HSe

General

Depending on the choice of options above the DressPack will have different content. The choice of routing will not affect the content. See tables for signal content below.

DressPack Type H/HSe. Parallel communication

- Option 16-1 with Connection to cabinet
- (Option 94-X to specify cable length)
- Option 455-1. Parallel communication
- Option 778-1. Material Handling
- Option 798-3. Internal routing, DressPack Lower arm

One of the options:

- Option 780-3 (and Option 798-3). External routing
- Option 780-4 (and option 798-3) Internal routing

The table below shows the available type of wires/media.

Type	At terminals in cabinet	At connection point. Base, Axis 3 or axis 6	Cable/part area	Allowed capacity
Customer Power (CP)				
Utility Power	2+2	2+2	0.75 mm ²	250 VAC, 5 A rms ⁱ
Protective earth		1	0.75 mm ²	250 VAC ⁱ
Customer Signals (CS)				
Signals twisted pair	12	12 (6x2) ⁱⁱ	0.2 mm ²	50 V DC, 1 A rms
Signals twisted pair and separate shielded	8	8 (4x2)	0.2 mm ²	50 V DC, 1 A rms
Media				
Air (PROC 1)		1	12.5 mm inner diameter	Max. air pressure 16 bar/230 PSI

ⁱ For option 780-3 50 VAC / 60 VDC.

ⁱⁱ For option 780-3 8 signals.

Continues on next page

DressPack Type H/HSe. Parallel and field bus communication, Can/DeviceNet

- Option 16-1 with Connection to cabinet
- (Option 90-X to specify cable length)
- Option 455-4. Parallel and bus communication
- Option 778-1 Material Handling
- Option 798-3. Internal routing, DressPack Lower arm

One of the options:

- Option 780-3 (and Option 798-3). External routing
- Option 780-4 (and option 798-3). Internal routing

The table below shows the available type of wires/media.

Type	At terminals in cabinet	At Connection point. Base, Axis 3 or axis 6	Cable/part area	Allowed capacity
Customer Power (CP)				
Utility Power	2+2	2+2	0.75 mm ²	250 VAC, 5 A rms ⁱ
Protective earth		1	0.75 mm ²	250 VAC ⁱ
Customer Signals (CS)				
Signals twisted pair	12	12 (6x2) ⁱⁱ	0.2 mm ²	50 V DC, 1 A rms
Signals twisted pair and separate shielded	8	8 (4x2)	0.2 mm ²	50 V DC, 1 A rms
Customer bus (CBus)				
Bus signals	At bus board	2	0.14 mm ²	Can/DeviceNet spec
Bus signals	At bus board	2	0.2 mm ²	50 V DC, 1 A rms
Media				
Air (PROC 1)		1	12.5 mm inner diameter	Max. air pressure 16 bar/230 PSI

ⁱ For option 780-3 50 VAC / 60 VDC.

ⁱⁱ For option 780-3, 8 signals instead of 12.

Continues on next page

2 DressPack

2.3.2 Configuration result for Type H HSe

Continued

DressPack Type H/HSe. Parallel and field bus communication, Profibus

- Option 16-1 with Connection to cabinet
- (Option 92-X to specify cable length)
- Option 455-4. Parallel and bus communication
- Option 778-1. Material Handling
- Option 798-3. Internal routing, DressPack Lower arm

One of the options:

- Option 780-3 (and Option 798-3). External routing
- Option 780-4 (and option 798-3) Internal routing

The table below shows the available type of wires/media.

Type	At terminals in cabinet	At connection point. Base, Axis 3 or axis 6	Cable/part area	Allowed capacity
Customer Power (CP)				
Utility Power	2+2	2+2	0,75 mm ²	250 VAC, 5 A rms ⁱ
Protective earth		1	0,75 mm ²	250 VAC ⁱ
Customer Signals (CS)				
Signals twisted pair	12	12 (6x2) ⁱⁱ	0,2 mm ²	50 V DC, 1 A rms
Signals twisted pair and separate shielded	8	8 (4x2)	0,2 mm ²	50 V DC, 1 A rms
Customer bus (CBus)				
Bus signals	At bus board	4	0,14 mm ²	Profibus 12 Mbit/s spec
Media				
Air (PROC 1)		1	12,5 mm inner diameter	Max. air pressure 16 bar/230 PSI

ⁱ For option 780-3 50 VAC / 60VDC.

ⁱⁱ For option 780-3, 8 signals instead of 12.

Continues on next page

DressPack Type H/HSe. Parallel and field bus communication, Ethernet

- Option 16-1 with Connection to cabinet
- (Option 859-X to specify cable length)
- (Option 94-X to specify cable length)
- Option 455-8. Parallel and Ethernet communication
- Option 778-1. Material Handling
- Option 798-3. Internal routing, DressPack Lower arm

One of the options:

- Option 780-3 (and Option 798-3). External routing
- Option 780-4 (and option 798-3). Internal routing

The table below shows the available type of wires/media.

Type	At terminals in cabinet	At connection point. Base, Axis 3 or axis 6	Cable/part area	Allowed capacity
Customer Power (CP)				
Utility Power	2+2	2+2	0.75 mm ²	250 VAC, 5 A rms ⁱ
Protective earth		1	0.75 mm ²	250 VAC ⁱ
Customer Signals (CS)				
Signals twisted pair	11	12 (4x3, 1 is N.C.) ⁱⁱ	0.2 mm ²	50 V DC, 1 A rms
Signals twisted pair and separate shielded	10	10 (5x2)	0.2 mm ²	50 V DC, 1 A rms
Customer bus (Ethernet)				
Bus signals	4	4	0.4 mm ²	Ethernet CAT 5e, 100 Mbit ⁱⁱⁱ
Media				
Air (PROC 1)		1	12.5 mm inner diameter	Max. air pressure 16 bar/230 PSI

ⁱ For option 780-3 50 VAC / 60 VDC.

ⁱⁱ For option 780-3, 8 signals instead of 12.

ⁱⁱⁱ Ethernet with wire colors according to PROFINET standard, M12-connectors.

Continues on next page

2 DressPack

2.3.2 Configuration result for Type H HSe

Continued

Required general options for Type HSe

To enable the spot welding function on the IRB 6700 a number of general standard robot options are required. These standard options are further described under other chapters and are also mentioned in this chapter.

- Option 727-1. 24V 8 Amps power supply
- Option 635-6. Spot. Software option for pneumatic guns

Required additional options for servo gun Type HSe

To enable the spot welding function to run with a servo controlled gun, some additional (additional to those described in [Summary options required for Type HSe on page 130](#)) servo drive options are required. These standard options are described under other chapters and are also mentioned below in this chapter.

- Option 907-1. First additional drive
- Option 864-1. Resolver connection, axis 7
- Option 785-5. Stationary gun
- Option 786-1,-2,-3,-4. Connection to first drive (Cable length to be stated)
- Option 635-6. Spot 6

Also option 630-1, Servo tool change, should be used if servo gun tool change is required.

2.3.3 Summary common options Type H HSe

General

The following options are the minimum required to form a complete spotwelding function DressPack Type H/HSe:

- Option 16-1. Connection to cabinet (Cable length and communication type to be stated)
- Option 455-1, 455-4 or 455-8. Parallel, Parallel and Bus communication or EtherNet (Communication type to be stated)
- Option 778-1. Material Handling
- Option 798-3. DressPack Lower arm (Internal routing in lower arm)
- Option 780-3, -4. DressPack Upper arm (External or internal routing)

2 DressPack

2.3.4 Summary options required for Type HSe

2.3.4 Summary options required for Type HSe

Servo gun

- Option 907-1. First additional drive
- Option 785-5. Stationary gun
- Option 786-1. Connection to first drive (other lengths available)
- Option 635-6. Spot 6

2.4 Type Se

2.4.1 Introduction

General

Variant Type Se is designed for robot handled servo-controlled tool (electrical gun). Included modules are shown in Figure below. Available configurations with linked option numbers are described below.

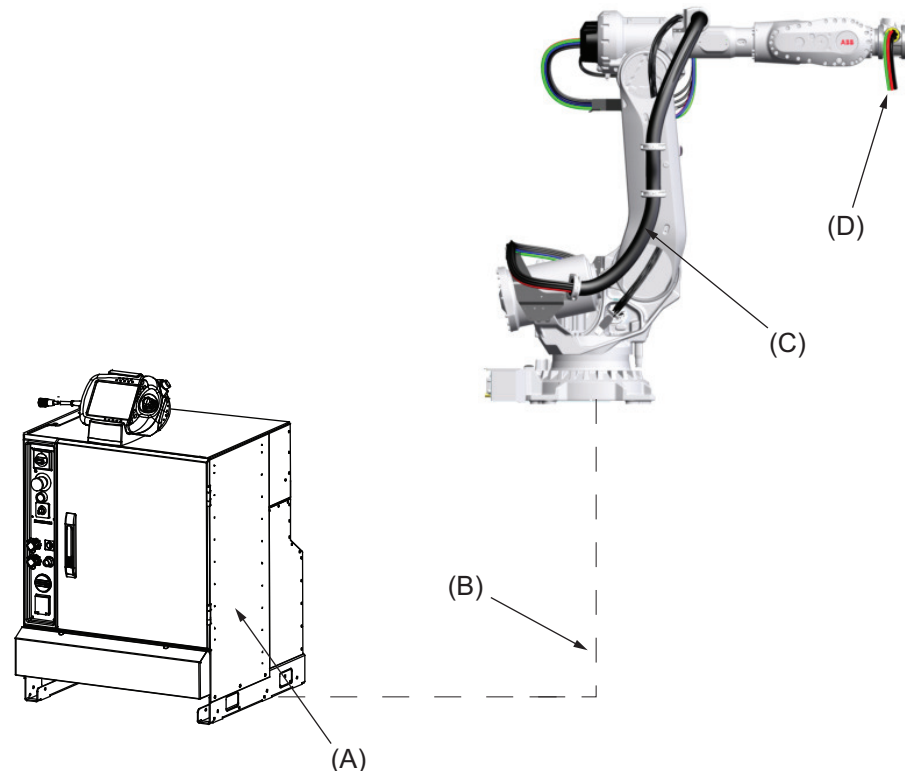

xx1300002179

Position	Name
A	Robot Cabinet IRC5 (including 7th axis drive), Se
B	DressPack, Floor
C	DressPack, Lower arm
D	DressPack, Upper arm

Available configurations with linked option numbers are described below. To achieve the specific servo motor connections within the DressPack for Type Se option 785-1 Robot gun must also to be chosen. See [Robot gun on page 102](#) for details.

Continues on next page

2 DressPack

2.4.1 Introduction

Continued

Option description

Option	Type	Description
16-1	Connection to cabinet	Floor cables and connections inside the I/O section for the DressPack are chosen. The length and configuration of the floor harness is specified under the options below. Option 94-X for parallel communication Option 90-X for parallel communication and field bus communication with Can/DeviceNet Option 92-X for parallel communication and field bus communication with Profibus
455-1	Parallel communication	Offers the signal cables needed for parallel communication in lower and upper arm DressPack. To be combined with option 94-X.
455-4	Parallel and Bus communication	Offers the signal cables needed for the combination of parallel and bus communication in combination in lower and upper arm DressPack. To be combined with option 90-X or 92-X.
455-8	Parallel and Ethernet	Offers the signal cables needed for the Ethernet communication in combination in lower and upper arm DressPack. To be combined with option 859-X. Requires selection of option 94-X.

Application Interface connected to Option 16-1, Cabinet	Option 455-1, Parallel communication	Option 94-X Cable length, Parallel communication	Option 778-2, Spot Welding
	Option 455-4, Parallel and Bus communication	Option 90-X Option 92-X Cable length, Parallel and Bus communication	
	Option 455-8, Parallel and Ethernet communication	Option 859-X Cable length, Ethernet communication	

DressPack

	Lower arm	Upper arm
Option 778-2 Spot Welding	Option 798-3, Base to axis 3 External routing	Option 780-4, Axis 3 to 6 Internal routing

2.4.2 Configuration result for Type Se

General

Depending on the choice of options above (combined with option 785-1 Robot gun) the DressPack will have different content. The choice of routing will not affect the content. See tables for signal content below.

DressPack Type Se. Parallel communication

- Option 16-1 with Connection to cabinet
- (Option 94-X to specify cable length)
- Option 455-1. Parallel communication
- Option 778-2. Spot Welding
- Option 798-3. External routing, DressPack Lower arm

and:

- Option 780-4 (and Option 798-3). Internal routing, DressPack Upper arm

The table below shows the available type of wires/media for type S.

Type S	At terminals in cabinet	At connection point. Base, axis 3 or axis 6	Cable/part area	Allowed capacity
Customer Power (CP)				
Utility Power	2+2	2+2	0.75 mm ²	250 VAC, 5 A rms
Protective earth		1	0.75 mm ²	250 VAC
Customer Signals (CS)				
Signals twisted pair	12	12 (6x2)	0.2 mm ²	50 V DC, 1 A rms
Signals twisted pair and separate shielded	8	8 (4x2)	0.2 mm ²	50 V DC, 1 A rms
Media				
Water/Air (PROC 1-4)		4	12.5 mm inner diameter ⁱ	Max. air pressure 16 bar/ 230 PSI Max. water pressure 10 bar/ 145 PSI
Welding power (WELD)				
Lower and Upper arm		2	35 mm ² ⁱⁱ	600 VAC, 150 A rms at 20 °C (68 °F)
Protective earth (Lower and Upper arm)		1		

ⁱ For LeanID 2x1/2" + 2x3/8", only upper arm

ⁱⁱ For LeanID upper arm 25 mm², only upper arm, 135 A rms

Continues on next page

2 DressPack

2.4.2 Configuration result for Type Se

Continued

The table below shows the available type of wires/media for type Se.

Type Se	At terminals in cabinet	At connection point. Base, axis 2/3 or axis 6	Cable/part area	Allowed capacity
Customer Power (CP)				
Utility Power	2+2	2+2	0.75 mm ²	250 VAC, 5 A rms
Protective earth		1	0.75 mm ²	250 VAC
Customer Signals (CS)				
Signals twisted pair	12	12 (6x2)	0.2 mm ²	50 V DC, 1 A rms
Signals twisted pair and separate shielded	8	8 (4x2)	0.2 mm ²	50 V DC, 1 A rms
Servo motor signals				
Servo motor power	At drive	3	1.5 mm ²	600 VAC, 12 A rms
Protective earth	At drive	1	1.5 mm ²	600 VAC
Signals twisted pair for resolver	-	6	0.23 mm ²	50 V DC, 1 A rms
Brake	-	2	0.23 mm ²	50 V DC, 1 A rms
Temperature control/PTC	-	2	0.23 mm ²	50 V DC, 1 A rms
Media				
Water/Air (PROC 1-4)		4	12.5 mm inner diameter ⁱ	Max. air pressure 16 bar/ 230 PSI. Max. water pressure 10 bar/ 145 PSI
Welding power (WELD)				
Lower and Upper arm		2	35 mm ² ii	600 VAC, 150 A rms at 20 °C (68 °F)
Protective earth (Lower and Upper arm)		1		

ⁱ For LeanID 2x1/2" + 2x3/8", only upper arm

ⁱⁱ For LeanID upper arm 25 mm², only upper arm, 135 A rms

Continues on next page

DressPack Type Se. Parallel and field bus communication, Can/DeviceNet

- Option 16-1 with Connection to cabinet
- (Option 90-X to specify cable length)
- Option 455-4. Parallel and bus communication
- Option 778-2. Spot Welding
- Option 798-3. External routing, DressPack Lower arm

and:

- Option 780-4 (and option 798-3). Internal routing, DressPack Upper arm

The table below shows the available type of wires/media for type S.

Type S	At terminals in cabinet	At connection point. Base, axis 3 or axis 6	Cable/part area	Allowed capacity
Customer Power (CP)				
Utility Power	2+2	2+2	0.75 mm ²	250 VAC, 5 A rms
Protective earth		1	0.75 mm ²	250 VAC
Customer signals (CS)				
Signals twisted pair	12	12 (6x2)	0.2 mm ²	50 V DC, 1 A rms
Signals twisted pair and separate shielded	8	8 (4x2)	0.2 mm ²	50 V DC, 1 A rms
Customer bus (CBus)				
Bus signals	At bus board	2	0.14 mm ²	Can/DeviceNet spec
Bus signals	At bus board	2	0.23 mm ²	50 V DC, 1 A rms
Media				
Water/Air (PROC 1-4)		4	12.5 mm inner diameter ⁱ	Max. air pressure 16 bar/230 PSI Max. water pressure 10 bar/145 PSI.
Welding power (WELD)				
Lower and Upper arm		2	35 mm ² ii	600 VAC,
Protective earth (Lower and Upper arm)		1		150 A rms at 20 °C (68 °F)

ⁱ For LeanID 2x1/2" + 2x3/8", only upper armⁱⁱ For LeanID upper arm 25 mm², only upper arm, 135 A rms

Continues on next page

2 DressPack

2.4.2 Configuration result for Type Se

Continued

The table below shows the available type of wires/media for type Se.

Type Se	At terminals in cabinet	At connection point. Base, axis 3 or axis 6	Cable/part area	Allowed capacity
Customer Power (CP)				
Utility Power	2+2	2+2	0.75 mm ²	250 VAC, 5 A rms
Protective earth		1	0.75 mm ²	250 VAC
Customer signals (CS)				
Signals twisted pair	12	12 (6x2)	0.2 mm ²	50 V DC, 1 A rms
Signals twisted pair and separate shielded	4	4 (2x2)	0.2 mm ²	50 V DC, 1 A rms
Customer bus (CBus)				
Bus signals	At bus board	2	0.14 mm ²	Can/DeviceNet spec
Bus signals	At bus board	2	0.23 mm ²	50 V DC, 1 A rms
Servo motor signals				
Servo motor power	At drive	3	1.5 mm ²	600 VAC, 12 A rms
Protective earth	At drive	1	1.5 mm ²	600 VAC
Signals twisted pair for resolver	-	6	0.23 mm ²	50 V DC, 1 A rms
Brake	-	2	0.23 mm ²	50 V DC, 1 A rms
Temperature control/PTC	-	2	0.23 mm ²	50 V DC, 1 A rms
Media				
Water/Air (PROC 1-4)		4	12.5 mm inner diameter ⁱ	Max. air pressure 16 bar/230 PSI. Max. water pressure 10 bar/145 PSI.
Welding power (WELD)				
Lower and Upper arm		2	35 mm ² ii	600 VAC, 150 A rms at 20 °C (68 °F)
Protective earth (Lower and Upper arm)		1		

ⁱ For LeanID 2x1/2" + 2x3/8", only upper arm

ⁱⁱ For LeanID upper arm 25 mm², only upper arm, 135 A rms

Continues on next page

DressPack Type Se. Parallel and field bus communication, Profibus

- Option 16-1 with Connection to cabinet
- (Option 92-X to specify cable length)
- Option 455-4. Parallel and bus communication
- Option 778-2. Spot Welding
- Option 798-3. External routing, DressPack Lower arm

and:

- Option 780-4 (and option 798-3). Internal routing, DressPack Upper arm

The table below shows the available type of wires/media for type S.

Type S	At terminals in cabinet	At connection point. Base, axis 3 or axis 6	Cable/part area	Allowed capacity
Customer Power (CP)				
Utility Power	2+2	2+2	0,75 mm ²	250 VAC, 5 A rms
Protective earth		1	0,75 mm ²	250 VAC
Customer signals (CS)				
Signals twisted pair	12	12 (6x2)	0,2 mm ²	50 V DC, 1 A rms
Signals twisted pair and separate shielded	8	8 (4x2)	0,2 mm ²	50 V DC, 1 A rms
Customer bus (CBus)				
Bus signals	At bus board	4	0,14 mm ²	Profibus 12 Mbit/s spec
Media				
Water/Air (PROC 1-4)		4	12,5 mm inner diameter ⁱ	Max. air pressure 16 bar/230 PSI Max. water pressure 10 bar/145 PSI.
Welding power (WELD)				
Lower and Upper arm		2	35 mm ² ii	600 VAC, 150 A rms at 20 °C (68 °F)
Protective earth (Lower and Upper arm)		1		

ⁱ For LeanID 2x1/2" + 2x3/8", only upper armⁱⁱ For LeanID upper arm 25 mm², only upper arm, 135 A rms

Continues on next page

2 DressPack

2.4.2 Configuration result for Type Se

Continued

The table below shows the available type of wires/media for type Se.

Type Se	At terminals in cabinet	At connection point. Base, axis 3 or axis 6	Cable/part area	Allowed capacity
Customer Power (CP)				
Utility Power	2+2	2+2	0,75 mm ²	250 VAC, 5 A rms
Protective earth		1	0,75 mm ²	250 VAC
Customer signals (CS)				
Signals twisted pair	12	12 (6x2)	0,2 mm ²	50 V DC, 1 A rms
Signals twisted pair and separate shielded	4	4 (2x2)	0,2 mm ²	50 V DC, 1 A rms
Customer bus (CBus)				
Bus signals	At bus board 6	6 (3x2)	0,14 mm ²	Profibus 12 Mbit/s spec
Servo motor signals				
Servo motor power	At drive	3	1,5 mm ²	600 VAC, 12 A rms
Protective earth	At drive	1	1,5 mm ²	600 VAC
Signals twisted pair for resolver	-	6	0,23 mm ²	50 V DC, 1 A rms
Brake	-	2	0,23 mm ²	50 V DC, 1 A rms
Temperature control/PTC	-	2	0,23 mm ²	50 V DC, 1 A rms
Media				
Water/Air (PROC 1-4)		4	12,5 mm inner diameter ⁱ	Max. air pressure 16 bar/230 PSI. Max. water pressure 10 bar/145 PSI.
Welding power (WELD)				
Lower and Upper arm		2	35 mm ² ii	600 VAC, 150 A rms at 20°C (68°F)
Protective earth (Lower and Upper arm)		1		

ⁱ For LeanID 2x1/2" + 2x3/8", only upper arm

ⁱⁱ For LeanID upper arm 25 mm², only upper arm, 135 A rms

Continues on next page

DressPack Type Se. Parallel and field bus communication, Ethernet

- Option 16-1 with Connection to cabinet
- (Option 859-X to specify cable length)
- (Option 94-X to specify cable length)
- Option 455-8. Parallel and Ethernet communication
- Option 778-2. Spot Welding
- Option 798-3. External routing, DressPack Lower arm

and:

- Option 780-4 (and Option 798-3). Internal routing, DressPack Upper arm

The table below shows the available type of wires/media for type S.

Type S	At terminals in cabinet	At connection point. Base, axis 3 or axis 6	Cable/part area	Allowed capacity
Customer Power (CP)				
Utility Power	2+2	2+2	0.75 mm ²	250 VAC, 5 A rms
Protective earth		1	0.75 mm ²	250 VAC
Customer signals (CS)				
Signals twisted pair	12	12 (6x2)	0.2 mm ²	50 V DC, 1 A rms
Signals twisted pair and separate shielded	8	8 (4x2)	0.2 mm ²	50 V DC, 1 A rms
Customer bus (Ethernet)				
Bus signals	4	4	0.4 mm ²	Ethernet CAT 5e, 100 Mbit ⁱ
Media				
Water/Air (PROC 1-4)		4	12.5 mm inner diameter ⁱⁱ	Max. air pressure 16 bar/230 PSI Max. water pressure 10 bar/145 PSI.
Welding power (WELD)				
Lower and Upper arm		2	35 mm ² ⁱⁱⁱ	600 VAC,
Protective earth (Lower and Upper arm)		1		150 A rms at 20°C (68°F)

ⁱ Ethernet with wire colors according to PROFINET standard, M12-connectors.ⁱⁱ For LeanID 2x1/2" + 2x3/8"ⁱⁱⁱ For LeanID upper arm 25 mm², 135 A rms

Continues on next page

2 DressPack

2.4.2 Configuration result for Type Se

Continued

The table below shows the available type of wires/media for type Se.

Type Se	At terminals in cabinet	At connection point. Base, axis 2/3 or axis 6	Cable/part area	Allowed capacity
Customer Power (CP)				
Utility Power	2+2	2+2	0.75 mm ²	250 VAC, 5 A rms
Protective earth		1	0.75 mm ²	250 VAC
Customer signals (CS)				
Signals twisted pair	12	12(6x2)	0.2 mm ²	50 V DC, 1 A rms
Signals twisted pair and separate shielded	8	8 (4x2)	0.2 mm ²	50 V DC, 1 A rms
Customer bus (Ethernet)				
Bus signals	4	4	0.4 mm ²	Ethernet CAT 5e, 100 Mbit ⁱ
Servo motor signals				
Servo motor power	At drive	3	1.5 mm ²	600 VAC, 12 A rms
Protective earth	At drive	1	1.5 mm ²	600 VAC
Signals twisted pair for resolver	-	6	0.23 mm ²	50 V DC, 1 A rms
Brake	-	2	0.23 mm ²	50 V DC, 1 A rms
Temperature control/PTC	-	2	0.23 mm ²	50 V DC, 1 A rms
Media				
Water/Air (PROC 1-4)		4	12.5 mm inner diameter ⁱⁱ	Max. air pressure 16 bar/230 PSI. Max. water pressure 10 bar/145 PSI.
Welding power (WELD)				
Lower and Upper arm		2	35 mm ² ⁱⁱⁱ	600 VAC, 150 A rms at 20°C (68°F)
Protective earth (Lower and Upper arm)		1		

ⁱ Ethernet with wire colors according to PROFINET standard, M12-connectors.

ⁱⁱ For LeanID 2x1/2" + 2x3/8"

ⁱⁱⁱ For LeanID upper arm 25 mm², 135 A rms

Continues on next page

Required options for servo gun, type Se

To enable the spot welding function to run with a servo controlled gun, some additional servo drive options are required. These standard options are described under other chapters and are also mentioned below in this chapter.

- Option 907-1. First additional drive
- Option 864-1. Resolver connection, axis 7
- Option 785-1. Robot Gun
- Option 786-1,-2,-3,-4. Connection to first drive (Cable length to be stated)
- Option 635-6. Spot 6.

Also option 630-1, Servo tool change, should be added if servo gun tool change is required.

Continues on next page

2 DressPack

2.4.3 Summary common options for Type Se

Continued

2.4.3 Summary common options for Type Se

General

The following options are the minimum required to form a complete SpotPack Type S/Se:

- Option 16-1. Connection to cabinet, (Cable length and communication type to be stated)
- Option 455-1, 455-4 or 455-8. Parallel, Parallel and Bus communication or EtherNet (Communication type to be stated)
- Option 778-2. Spot Welding
- Option 798-3. External routing, DressPack Lower arm
- Option 780-4 Internal routing, DressPack Upper arm

Servo gun type Se

- Option 907-1. First additional drive
- Option 785-1. Robot Gun
- Option 786-1,-2,-3,-4. Connection to first drive (cable length to be stated)
- Option 635-6. Spot 6

2.5 Connection kits

General

For detailed information on connection location see [Interface descriptions for DressPack on page 114](#)

Below is an example of how a connector kit and its parts can look like.



xx130000223

Continues on next page

2 DressPack

2.5.1 Base - Connector kits

2.5.1 Base - Connector kits

Available options

		DressPack options	Resolver conn., axis 7	Description
Option	Name	798-3	864-1	
459-1	CP/CS, Proc 1 on base	X		
453-1	FB 7		X	



Note

Ethernet and Servo power connection kits not available.

Option 459-1, CP/CS, Proc 1 on base

R1. CP/CS and Proc 1 on base for option 798-3.

This option offers a kit with connectors. This must be assembled by the customer.

The kit contains:

- 1 Hose fittings (Swivel nut adapter, (1/2", M22x1,5 Brass, 24 degree seal))
- Connector with:

1 pcs Hood Foundry (Harting)	HAN EMC / M 40
1 pcs Hinged frame (Harting)	Shell size 16
2 pcs Multicontact, female (Harting)	Type HD (25 pin)
1 pcs Multicontact, female (Harting)	Type DD (12 pin)
1 pcs Multicontact, female (Harting)	Type EE (8 pin)
10 pcs Female crimp contacts	For 1,5 mm ²
10 pcs Female crimp contacts	For 0,5 mm ²
10 pcs Female crimp contacts	For 1,0 mm ²
10 pcs Female crimp contacts	For 2,5 mm ²
12 pcs Female crimp contacts	For 0,14– 0,37 mm ²
45 sockets	For 0,2– 0,56 mm ²
Assembly Accessories to complete connector	
Assembly instruction	

Continues on next page

Option 453-1, FB 7**R3. FB 7 on base for option 864-1**

This option offers a kit with a connector. This must be assembled by the customer.

The kit contains:

- Connector with:

1 pcs Multiple connector (pin)	UTOW
1 pcs Adaptor	8 pin
8 pcs Pin	for 0,13-0,25 mm ²
Assembly Accessories to complete connector	
Assembly instruction	

2 DressPack

2.5.2 Axis 3 - Connector kits

2.5.2 Axis 3 - Connector kits

Available options

		DressPack options	Description
Option	Name	798-3	
458-1	CP/CS,CBUS/SP/SS Proc 1 axis 3 CP/CS bus, Proc 1 axis 3	X	UTOW

Option 458-1, CP/CS/CBus/SP/SS, Proc 1 axis 3

CP/CS/CBus/SP/SS, Proc 1 axis 3 on tool side for option 780-3 and 780-4.

This kit offers a kit with connectors to be mounted at toolside of axis 3.

This must be assembled by the customer.

The kit contains:

- 1 Hose fitting (Parker Push lock (1/2", M22x1,5 Brass, 24 degree seal))
- Connector with:

CP/CS	
1 pcs UTOW Pin connector 26p, bulkhead	UTOW71626PH05, Shell size 16
26 pcs Pin	RM18W3K, 0.21-0.93 mm ²
CBUS	
1 pcs UTOW Pin connector 10p, bulkhead	UTOW71210PH05 Shell size 12
10 pcs Pin	RM18W3K, 0.21-0.93 mm ²
Ethernet	
1 pcs Socket connector M12	Harting 2103 88
4 pcs Socket	Harting 61 03 0, 0.13-0.33 mm ²
SP (Servo Power)	
1 pcs Bulkhead contact M23	
4 pcs Crimp pin 1 mm	AWG 24-17
4 pcs Crimp pin 2 mm	AWG 18-14
SS (Servo Signal)	
1 pcs Bulkhead contact M23	
17 pcs Pin	AWG 28-20
Assembly Accessories to complete connector	
Assembly instruction	

2.5.3 Axis 6 - Connector kits

Available options

Option	Name	780-3(MH)	780-4(LeanID)	Description
543-1	CP/CS/CBUS/SP/SS Proc 1 axis 6	X	X	UTOW
452-1	Weld Proc 1-4 axis 6		X	MC, Seperate conductors

Option 543-1, CP/CS/CBus/SP/SS, Proc 1 axis 6

CP/CS/CBus/SP/SS, Proc 1 axis 6 on tool side for option 780-3 and 780-4.

This kit offers a kit with connectors to be mounted at toolside of axis 6.

This must be assembled by the customer.

The kit contains:

- 1 Hose fitting (Swivel nut adapter (1/2", M22x1,5 Brass, 24 degree seal))
- Connector with:

CP/CS	
1 pcs UTOW Pin connector 26p, bulkhead	UTOW71626PH05, Shell size 16
26 pcs Pin	RM81W3K, 0.21-0.93 mm ²
CBUS	
1 pcs UTOW Pin connector 10p, bulkhead	UTOW71210PH05 Shell size 12
10 pcs Pin	RM18W3K, 0.21-0.93 mm ²
Ethernet	
1 pcs Socket connector M12	Harting 2103 88
4 pcs Socket	Harting 61 03 0, 0.13-0.33 mm ²
SP (Servo Power)	
1 pcs Bulkhead contact M23	
4 pcs Crimp pin 1 mm	AWG 24-17
4 pcs Crimp pin 2 mm	AWG 18-14
SS (Servo Signal)	
1 pcs Bulkhead contact M23	
17 pcs Pin	AWG 28-20
Assembly Accessories to complete connector	
Assembly instruction	

Continues on next page

2 DressPack

2.5.3 Axis 6 - Connector kits

Continued

Option 452-1, Weld, Proc 1-4 axis 6

Weld and Proc 1-4 axis 6 on manipulator side for option 780-4

The process cable package from axis 6 ends with free end for media and for weld power cable. The option 452-1 offers a kit for connectors. This must be assembled by the customer when hoses and power cable has been cut to required length.

The kit contains:

- 4 Hose fittings (Swivel Nut adapter, (2 x 1/2", M22x1,5) and (2x 3/8", M16x1.5))
- 1 Multi contact connector (Female) type including:

• 1 pc Welding connector	3x25 mm ²
1 pc Cable gland	Diameter 24-28 mm
1 pc End housing	0,21-0,93 mm ²
1 pcs Reducing coupling	PG36/PG29
Assembly Accessories to complete connector	
Assembly instruction	

3 Specification of variants and options

3.1 Introduction to variants and options

General

The different variants and options for the IRB 6700 are described in the following sections. The same option numbers are used here as in the specification form.

The variants and options related to the robot controller are described in the product specification for the controller.

3 Specification of variants and options

3.2 Manipulator

3.2 Manipulator

Variants

Option	IRB Type	Handling capacity (kg)	Reach (m)
435-111	6700	235	2.65
435-112	6700	205	2.80
435-113	6700	175	3.05
435-114	6700	150	3.20
435-115	6700	200	2.60
435-116	6700	155	2.85
435-126	6700	300	2.70
435-127	6700	245	3.00
435-138	6700Inv	300	2.60
435-139	6700Inv	245	2.90

Manipulator color

Option	Description	Note
209-1	ABB Orange standard	
209-2	ABB White standard	
209-202	ABB Graphite White standard	Standard color
209-4 --192	Colors according to RAL-codes	



Note

Notice that delivery time for painted spare parts will increase for none standard colors.

Protection types

Option	Protection type	Note
287-4	Standard	IP67
287-3	Foundry Plus 2	See Protection type Foundry Plus 2 on page 11 for a complete description of protection type Foundry Plus 2.

Continues on next page

Warranty

For the selected period of time, ABB will provide spare parts and labour to repair or replace the non-conforming portion of the equipment without additional charges. During that period, it is required to have a yearly Preventative Maintenance according to ABB manuals to be performed by ABB. If due to customer restrains no data can be analyzed in the ABB Ability service *Condition Monitoring & Diagnostics* for robots with OmniCore controllers, and ABB has to travel to site, travel expenses are not covered. The Extended Warranty period always starts on the day of warranty expiration. Warranty Conditions apply as defined in the Terms & Conditions.



Note

This description above is not applicable for option *Stock warranty* [438-8]

Option	Type	Description
438-1	Standard warranty	Standard warranty is 12 months from <i>Customer Delivery Date</i> or latest 18 months after <i>Factory Shipment Date</i> , whichever occurs first. Warranty terms and conditions apply.
438-2	Standard warranty + 12 months	Standard warranty extended with 12 months from end date of the standard warranty. Warranty terms and conditions apply. Contact Customer Service in case of other requirements.
438-4	Standard warranty + 18 months	Standard warranty extended with 18 months from end date of the standard warranty. Warranty terms and conditions apply. Contact Customer Service in case of other requirements.
438-5	Standard warranty + 24 months	Standard warranty extended with 24 months from end date of the standard warranty. Warranty terms and conditions apply. Contact Customer Service in case of other requirements.
438-6	Standard warranty + 6 months	Standard warranty extended with 6 months from end date of the standard warranty. Warranty terms and conditions apply.
438-7	Standard warranty + 30 months	Standard warranty extended with 30 months from end date of the standard warranty. Warranty terms and conditions apply.
438-8	Stock warranty	<p>Maximum 6 months postponed start of standard warranty, starting from factory shipment date. Note that no claims will be accepted for warranties that occurred before the end of stock warranty. Standard warranty commences automatically after 6 months from <i>Factory Shipment Date</i> or from activation date of standard warranty in WebConfig.</p> <div data-bbox="826 1751 888 1809" data-label="Image"> </div> <p>Note</p> <p>Special conditions are applicable, see <i>Robotics Warranty Directives</i>.</p>

Continues on next page

3 Specification of variants and options

3.2 Manipulator

Continued

Warranty for DressPack



Note

Option 780-3 upper arm DressPack HM3 is not covered by warranty.



Note

Option 780-4 DressPack LeanID is covered by the warranty.

Foundry Plus Cable Guard

The manipulator cables are equipped with an additional protection of aluminized leather against e.g. aluminium spits and flashes and chips from machining. Process cable for material handling from base to axis 3, option 798-3 has the same protection.

Option	Type	Description
908-1	Foundry Cable Guard	For extra protection of cables. Requires option 287-3 Foundry Plus.

Upper arm cover

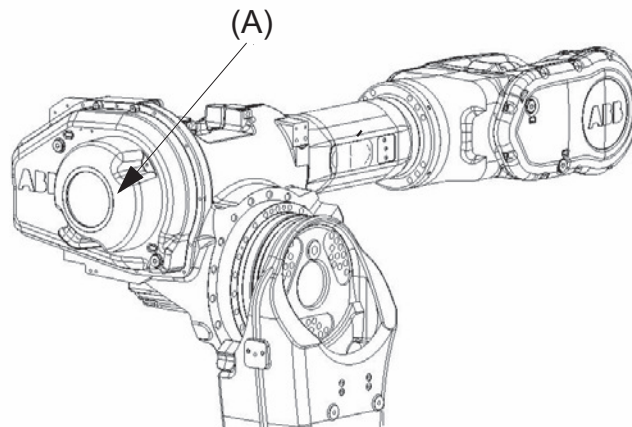

xx1400002039

Pos	Description
A	Option 430-1

Fork lift device

Option	Type	Description
159-1	Fork lift device IRB 6700 ⁱ	Lifting device on the IRB 6700 floor standing manipulator for fork-lift handling. Note! When Cooling Fan for axis 1 motor unit is used, this must be disassembled in order to use fork lift device.
159-2	Fork lift device IRB 6700Inv ⁱ	For IRB 6700Inv hoses and adapter are not supplied. These have to be arranged by the customer.

ⁱ Its recommended to remove the fork lift devices after use

Continues on next page

Working range limitation

To increase the safety of the robot, the working range of axis 1 can be restricted by extra mechanical stops.

Option	Type	Description
29-1	Axis 1, 15 degrees	Two stops which allow the working range to be restricted in increments of 15°.

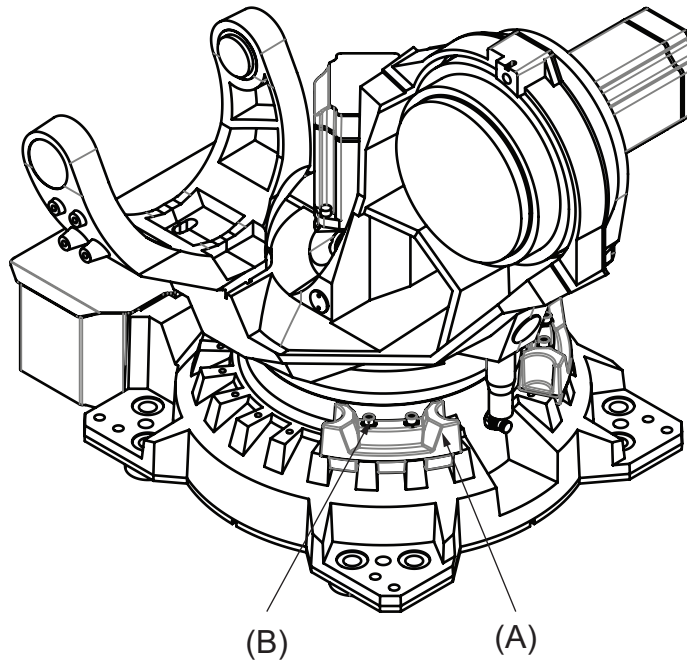

xx1400002035

Pos	Description
A	Two mechanical stops
B	Bolt tightening torque: 60 Nm

Extended working range

Option	Type	Description
561-1	Extended work range axis 1	<p>The option extends the working range on axis 1 from $\pm 170^\circ$ to $\pm 220^\circ$.</p> <p>The option 561-1 requires option 810-2, SafeMove.</p> <p>When the option is used, the mechanical stop can after a risk-assessment be removed.</p>

Continues on next page

3 Specification of variants and options

3.2 Manipulator

Continued



CAUTION

The option *Extended work range* enables an extension of the working range for axis 1, through a software configuration. With this option installed, the working range can exceed the range limited by the mechanical stop on axis 1. The working range shall be limited through the option SafeMove.

A risk analysis must be done to ensure that no risks remain when using option *Extended work range*, to limit the working range, and before removing the mechanical stops.

For information about the option SafeMove, see *Application manual - Functional safety and SafeMove2*.

If the mechanical stop is removed, then the manipulator should have a marking for this, for example, a label. If the robot is delivered with the option *Extended work range*, then such a label is included on delivery.

3.3 Equipment

General

Option	Type	Description
213-1	Safety lamp	A safety lamp with an orange fixed light can be mounted on the manipulator. The lamp is active in MOTORS ON mode. The safety lamp is required on a UL/UR approved robot.
37-1	Base plate	Can also be used for IRB 7600. See Installation on page 22 , for dimension drawing. ⁱ
87-1	Cooling fan for axis 1 motor (IP54)	For in use recommendations see Cooling fan for axis 1 motor on page 99 . Not for protection Foundry Plus. Not together with track motion.
430-1	Upper arm covers	See Figure in Upper arm cover on page 152 . Included in protection Foundry.
804-1	Labels for synchronization markings	For a more accurate marking of the synchronization position of the robot. Assembly instructions are included. See Figure for Synchronize labels, Axis 1 - 6.

ⁱ Can not be used for IRB 6700Inv.

Synchronization labels

The option contains labels for each axis. Below is an example of the synchronization labels.

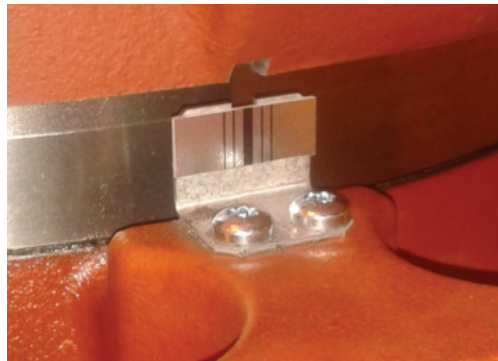

xx1300001127

Electronic Position Switches (EPS)

The mechanical position switches indicating the position of the three main axes are replaced with electronic position switches for up to 7 axes, for increased flexibility and robustness. For more detailed information, see *Product specification - Controller IRC5* and *Application manual - Electronic Position Switches*.

Resolver connection, axis 7

Option	Description	Note
864-1	On base	Used together with first additional drive, option 907-1.

Continues on next page

3 Specification of variants and options

3.3 Equipment

Continued

Standard calibration method

Option	Type	Description
1999-1	Axis calibration	Preferred standard calibration method. Robust, high performance axis calibration using only mechanical calibration stops and software.
1999-2	Calibration Pendulum	Previous standard calibration method only to be used in special cases if customers would like to harmonize calibration with already installed base. ⁱ

ⁱ This option is not available for IRB 6700Inv



Note

The calibration methods are not interchangeable.

3.4 Floor cables

Manipulator cable length

Option	Lengths
210-2	7 m
210-3	15 m
210-4	22 m
210-5	30 m

3 Specification of variants and options

3.5 Process DressPack

3.5 Process DressPack

Connection to

Option	Connection to	Description
16-1	Cabinet	The signals CP/CS are connected to 12-pole screw terminals, Phoenix MSTB 2.5/12-ST-5.08, in the controller. The cable between R1.CP/CS and the controller is supplied.

Communication

Option	Type	Description
455-1	Parallel communication	Includes customer power CP, customer signals CS.
455-4	Parallel and bus communication	Includes CP, customer signals and CAN/DeviceNet or Profibus for process cable package.
455-8	Parallel and Ethernet communication	Includes CP, customer signals and PROFINET or Ethernet/IP for process cable package

3.6 DressPack floor cables

Connection to Parallel/CAN DeviceNet/Profibus/Ethernet

Following information specifies the cable length for Parallel, CANDeviceNet/Profibus/Ethernet for connection to cabinet.

Option	Lengths	Description
90-2/92-2	7 m	
90-3/92-3	15 m	
90-4/92-4	22 m	
90-5/92-5	30 m	

3 Specification of variants and options

3.7 DressPack Lower and Upper arm

3.7 DressPack Lower and Upper arm

DressPack process configuration



Note

For more information about the process cable packages, see [DressPack on page 112](#)

Option	Description	Note
778-1	Material Handling	Includes signals and one air hose.
778-2	Spot Welding	Includes signals, weld power cable, one air hose and three media hoses.

DressPack lower arm

Option	Description	Note
798-3	Routing from base to axis 3	Material Handling/Spot Welding

DressPack upper arm

Option	Description	Note
780-3	External routing from axis 3 to axis 6	Requires option 778-1 and option 798-3 ⁱ .
780-4	Internal routing from axis 3 to axis 6	Requires option 798-3. ⁱ

ⁱ Upper arm cabling is not available for IRB 6700Inv together with option Foundry plus 2.



Note

If option 780-4, LeanID, is selected the payload will decrease, for detailed information see [Load diagrams on page 37](#)

3.8 Connection kits

General

The connectors fit to the connectors at the manipulator base, axis 3 and 6 respectively.

Content

The kit consists of connectors, pins and sockets. For technical description, see [Connection kits on page 143](#).

Option	Type	Description
459-1	R1.CP/CS, PROC1	For the Customer Power/Customer Signal connector and one Process connector on the manipulator base. Sockets for bus communication are included.
453-1	R3.FB7	For the 7-axis connector on the manipulator base.
458-1	R2.CP/CS, PROC1	For the Customer Power/Customer Signal connector and one Process connector at axis 3. Pins for bus communication are included.
452-1	Weld, PROC1-4 axis 6	Weld connector and four Process connectors at axis 6, the manipulator side.
543-1	CP/CS/BUS, PROC1 axis 6	Connector for customer power/customer signal/customer bus at axis 6 tool side.

3 Specification of variants and options

3.9 Servo Gun

3.9 Servo Gun

Content

For technical description see [Servo gun on page 100](#).

Option	Lengths
785-1	For robot handled Servo Gun.
785-2	For Stationary Servo Gun.

Connection to first drive

Following information specifies the cable length for Connection to first drive. For further information see [Servo gun on page 100](#).

Option	Lengths
786-1	7 m
786-2	15 m
786-3	22 m
786-4	30 m

3.10 User documentation

User documentation

The user documentation describes the robot in detail, including service and safety instructions.



Tip

All documents can be found via myABB Business Portal, www.abb.com/myABB.

This page is intentionally left blank

4 Accessories

4.1 Introduction to accessories

General

There is a range of tools and equipment available, especially designed for the manipulator.

Basic software and software options for robot and PC

For more information, see *Product specification - Controller IRC5* and *Product specification - Controller software IRC5*.

Robot peripherals

- Track Motion
- Motor Units

This page is intentionally left blank

Index

A

Absolute Accuracy, 34
Absolute Accuracy, calibration, 32
accessories, 165

C

calibration
 Absolute Accuracy type, 31
 standard type, 31
calibration, Absolute Accuracy, 32
Calibration Pendulum, 33
CalibWare, 31
category 0 stop, 98
category 1 stop, 98
compensation parameters, 34

D

documentation, 163
DressPack warranty, 152

E

Electronic Position Switches, 155
EPS, 155
equipment, on robot, 72
extended working range, 154

F

fine calibration, 33
fitting equipment to robot, 72

H

holes for equipment, 72

I

instructions, 163

M

manuals, 163

O

option
 Extended working range, 154
options, 149

P

product standards, 20

S

safety standards, 20
service instructions, 163
standards, 20
 ANSI, 20
 CAN, 20
 EN IEC, 20
 EN ISO, 20
standard warranty, 151
stock warranty, 151
stopping distances, 98
stopping times, 98

U

user documentation, 163

V

variants, 149

W

warranty, 151
warranty for DressPack, 152



ABB AB

Robotics & Discrete Automation

S-721 68 VÄSTERÅS, Sweden

Telephone +46 (0) 21 344 400

ABB AS

Robotics & Discrete Automation

Nordlysvegen 7, N-4340 BRYNE, Norway

Box 265, N-4349 BRYNE, Norway

Telephone: +47 22 87 2000

ABB Engineering (Shanghai) Ltd.

Robotics & Discrete Automation

No. 4528 Kangxin Highway

PuDong District

SHANGHAI 201319, China

Telephone: +86 21 6105 6666

ABB Inc.

Robotics & Discrete Automation

1250 Brown Road

Auburn Hills, MI 48326

USA

Telephone: +1 248 391 9000

abb.com/robotics